

PART NUMBER	SEAL O-RING	PCB LOCATING POST
RASH10	NO	NO
RASH10S	YES	
RASH10P	NO	YES
RASH10PS	YES	

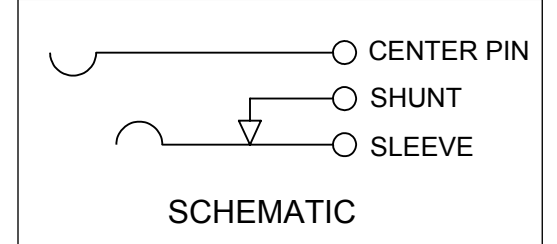
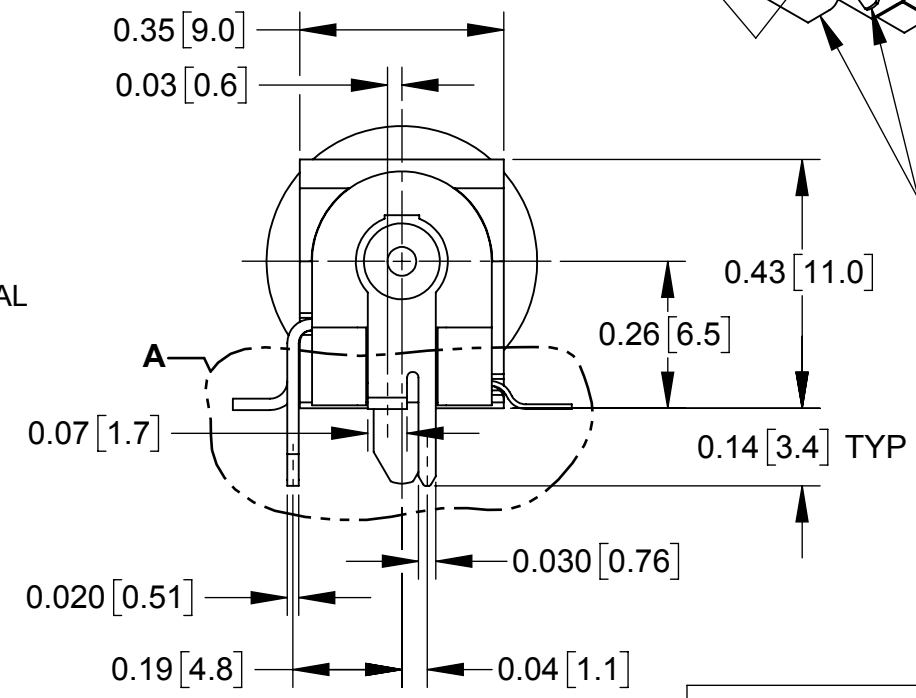
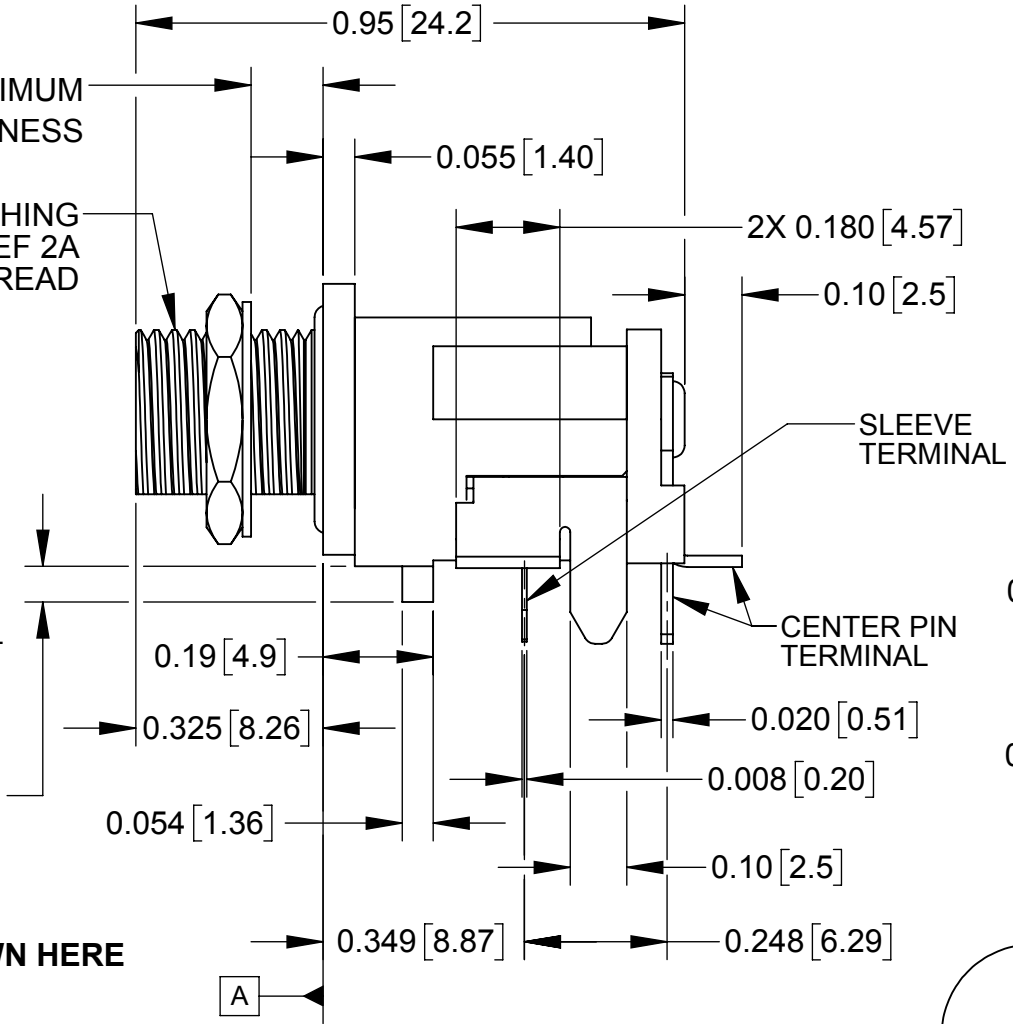
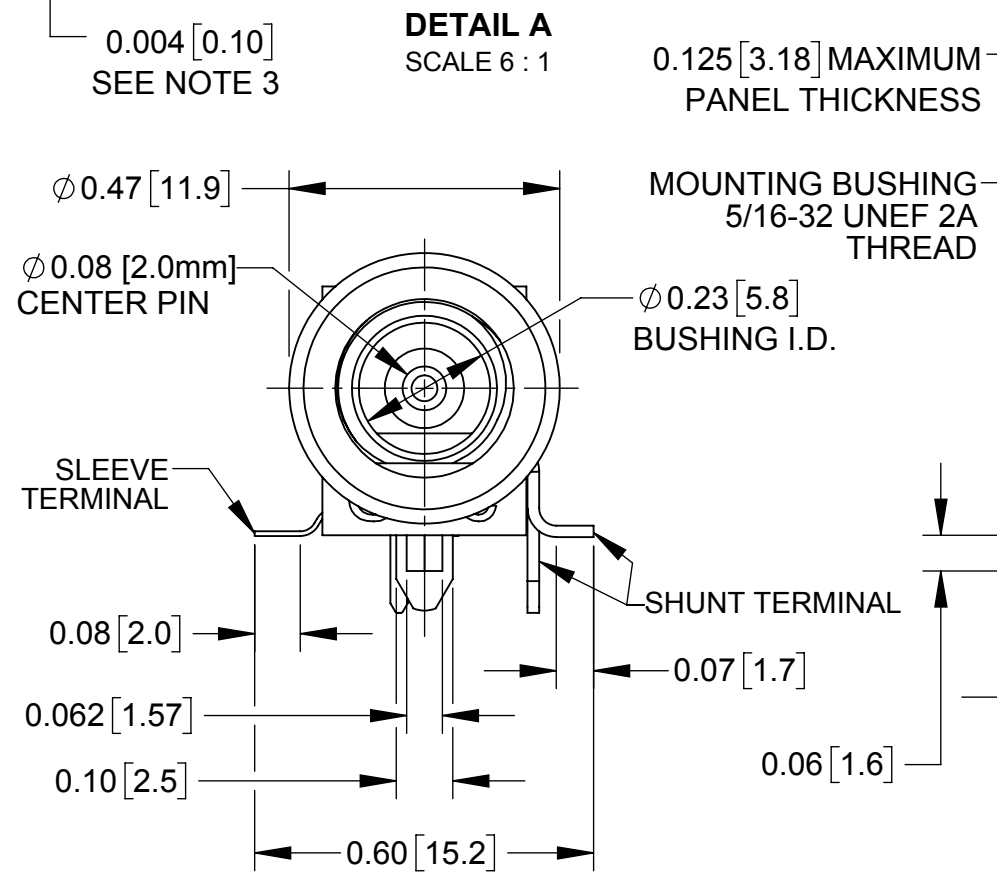
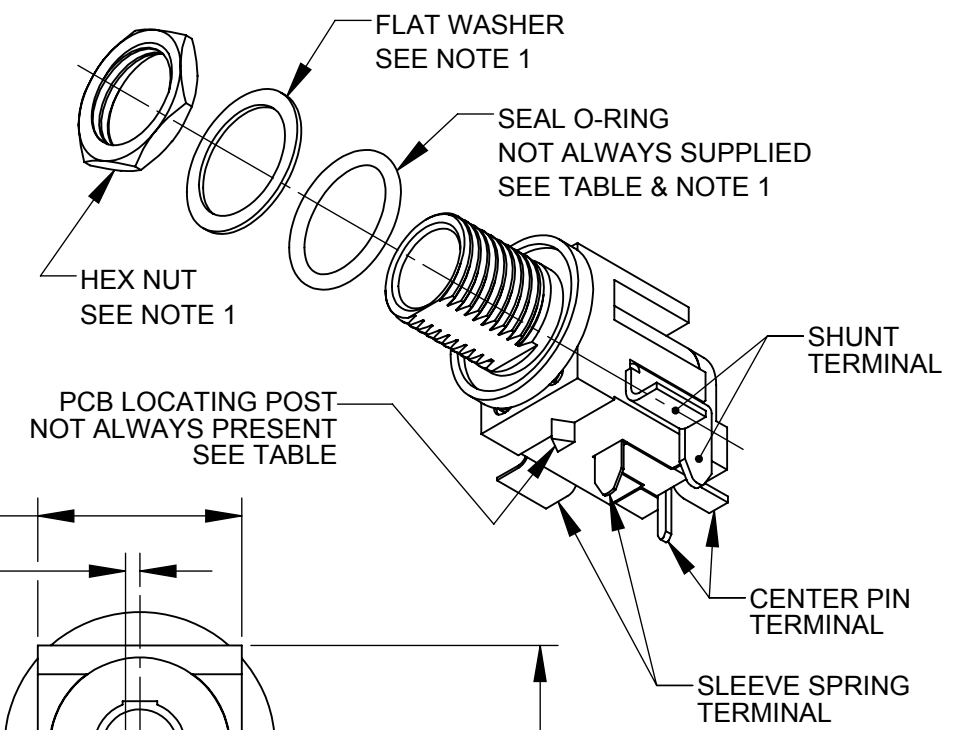

RASH10PS SHOWN HERE

- NOTES:
- HEX NUT, WASHER, AND O-RING (IF REQUIRED) SUPPLIED UNASSEMBLED.
 - MATERIAL:
 HOUSING, COVER: THERMOPLASTIC, BLACK
 MOUNTING BUSHING, HEX NUT: COPPER ALLOY, NICKEL PLATED
 CENTER PIN: COPPER ALLOY, NICKEL PLATED
 PIN AND SHUNT TERMINALS: COPPER ALLOY, SILVER PLATED
 SLEEVE SPRING TERMINAL: SPRING COPPER ALLOY, SILVER PLATED
 FLAT WASHER: STEEL, NICKEL PLATED
 O-RING: ELASTOMER, BLACK
 - HIGH POINT OR EDGE OF EACH OF THE THREE SOLDER TABS SHALL BE WITHIN A ZONE DEFINED BY COPLANARITY OF 0.004 INCH. SURFACE [A] SHALL BE 0.002 BELOW OR 0.010 ABOVE THE PLANE ESTABLISHED BY THE THREE HIGH POINTS OR EDGES OF THE THREE SOLDER TABS.
 - THESE PRODUCTS ARE RoHS COMPLIANT.

RECOMMENDED PANEL CUT-OUT

CUSTOMER DRAWING

REV	ECO NUMBER	DATE	BY	APVD
A	27139	04/29/13	PC	TJK
REVISIONS				

UNLESS OTHERWISE SPECIFIED

1. ALL DIMENSIONS IN INCHES [mm]
 - TWO PLACE DECIMALS ±0.02 [0.5]
 - THREE PLACE DECIMALS ±0.005 [0.13]

DO NOT SCALE DRAWING

THIS DRAWING DESCRIBES A DESIGN CONSIDERED PROPRIETARY IN NATURE, DEVELOPED AND MANUFACTURED BY SWITCHCRAFT INC. AND IS RELEASED ON A CONFIDENTIAL BASIS FOR IDENTIFICATION PURPOSES ONLY.										
SIZE	WIDTH	MULT	LBS/M	TEMPER						
FINISH SPEC No.					MATERIAL SPEC No.					
FIRST USED ON					SCALE 3:1					
DATE DRAWN	BY	CHKD	APVD							
02/17/12	PNK	PNK	SRC							
					02/17/12 02/17/12					
NAME RA POWER JACKS, HYBRID HIGH AMP, Ø0.08 [2.0mm] PIN, RoHS								PART No.		REV
								RASH10 SERIES		A

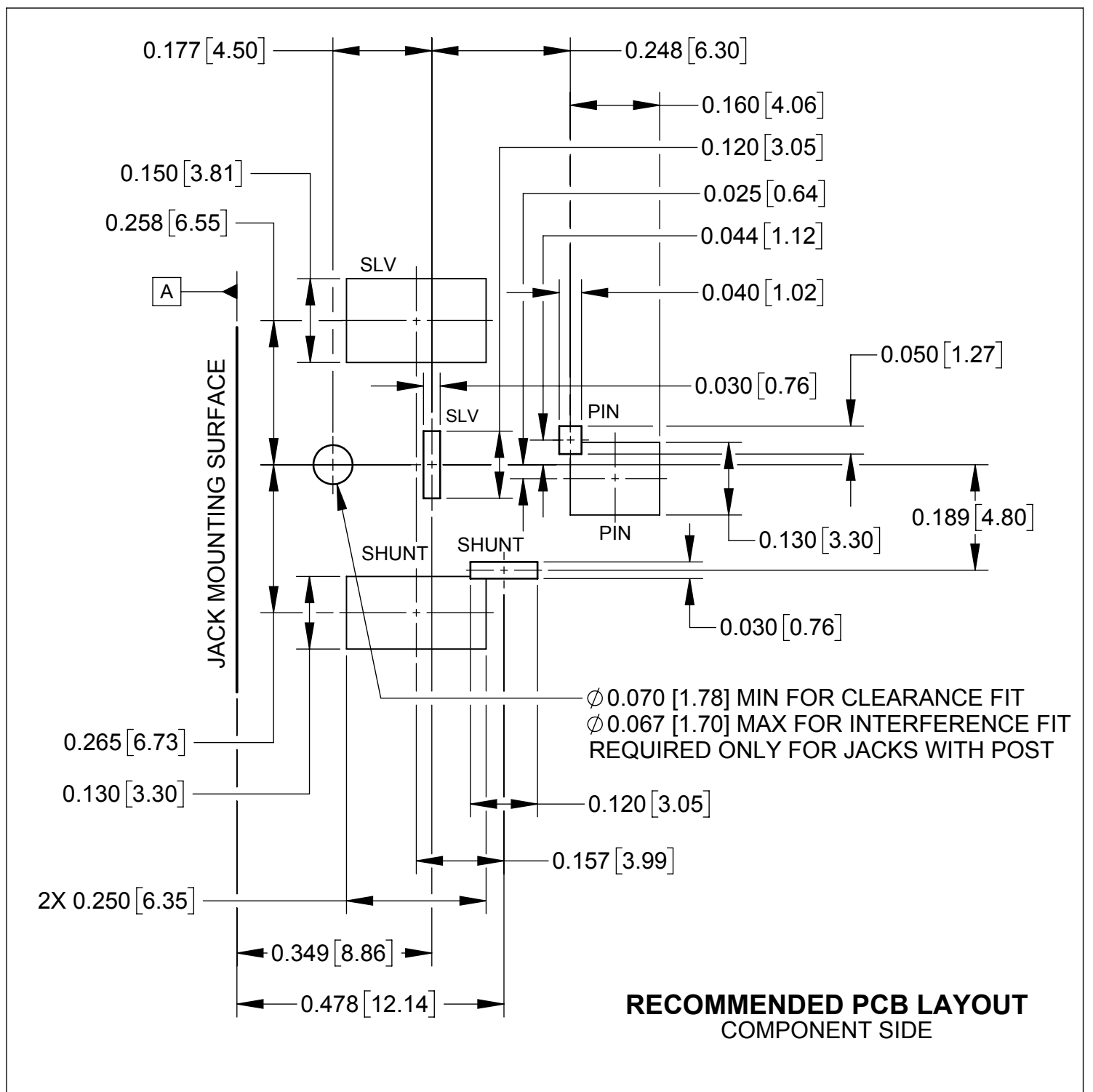
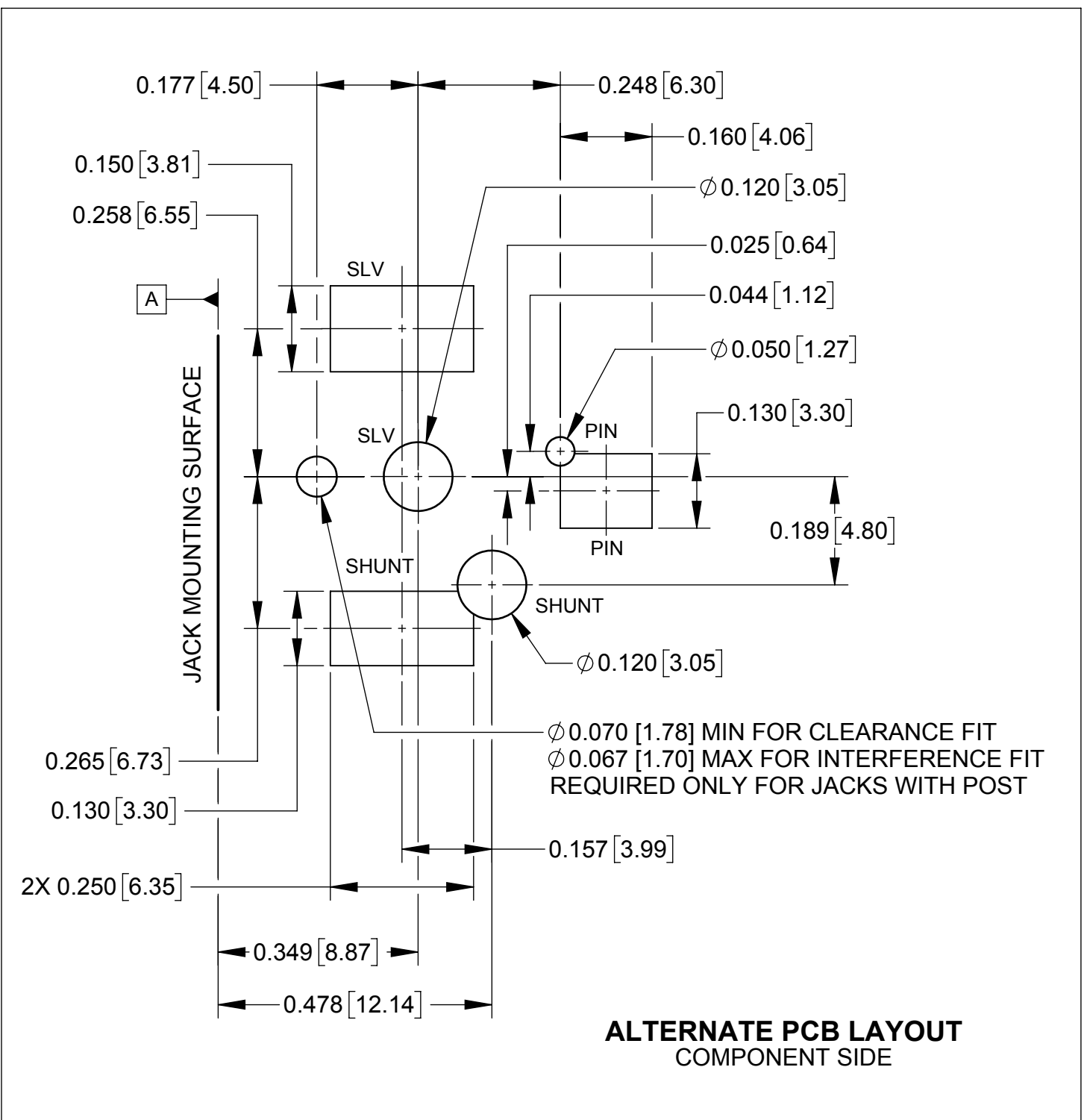

CUSTOMER DRAWING

SCALE 4:1	Switchcraft [®]	
DATE DRAWN 12/03/19		
DRAWN BY PC	PART No. RASH10 SERIES	REV A