

注記 NOTES

- △1 ロック窓 LOCKING WINDOW:
ロック窓は、2、3極では1ヶ所、4極以上では2ヶ所とする。
ONE PLACE FOR 2 AND 3 CIRCUIT.
TWO PLACES FOR 4 CIRCUIT AND MORE.
- △2 材料およびめっき仕様：TABLE1参照
MATERIAL AND PLATING: REFER TO TABLE1
- 3 本製品は金めっき品です。錫めっき品は530470000-SDをご参照ください。
THIS PRODUCT IS GOLD PLATING TYPE.
PLEASE REFER TO 530470000-SD FOR TIN PLATING TYPE.
- △4 適用製品及び各種仕様書はSHEET 2を参照のこと
REFER TO SHEET 2 ABOUT APPLICABLE PRODUCTS
AND VARIOUS SPECIFICATIONS
- △5 発注番号
ORDER NUMBER

53047* * *0

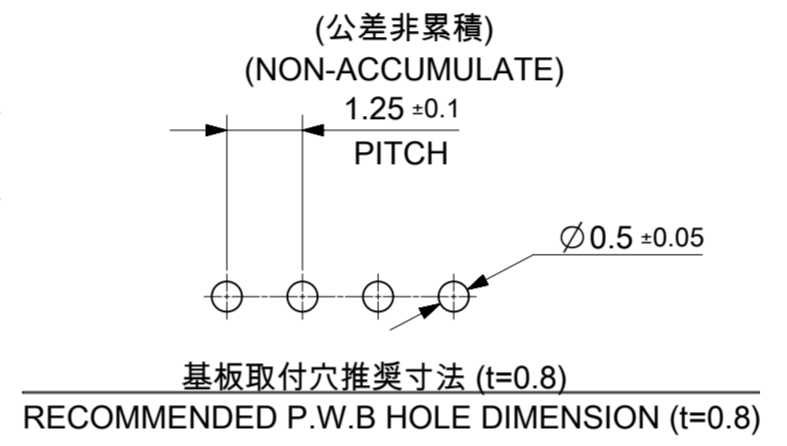
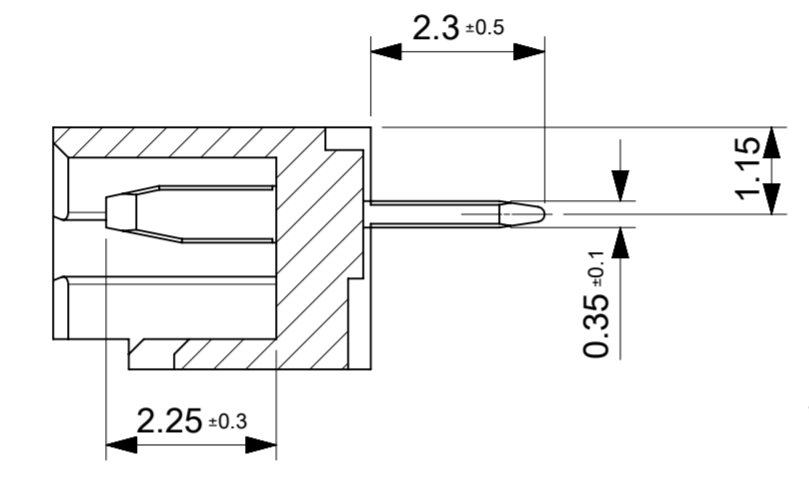
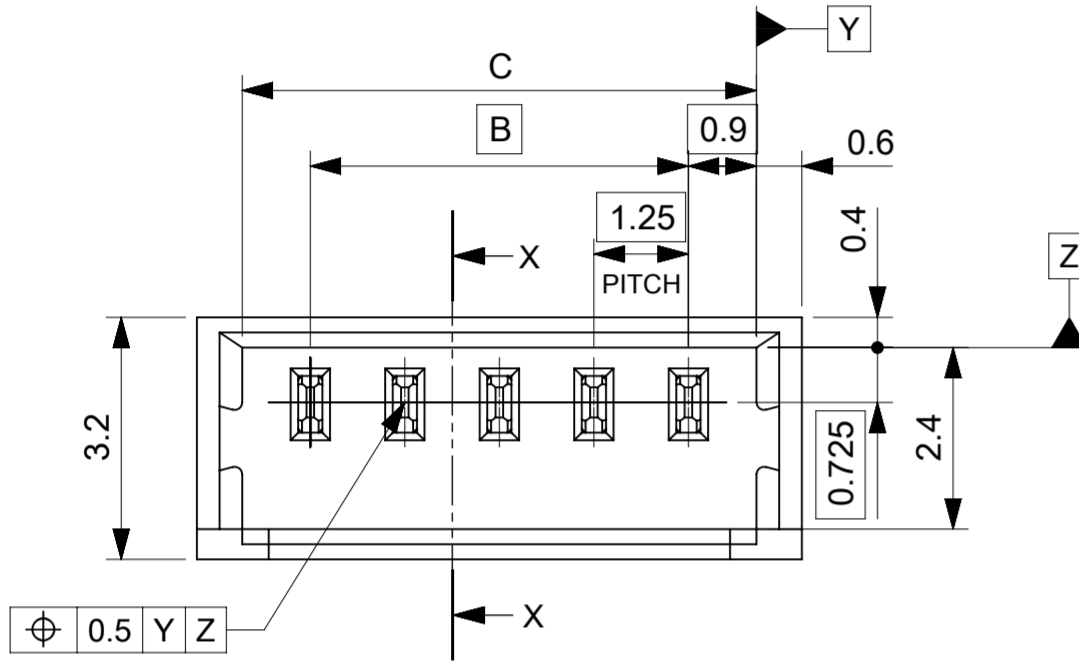

極数 CIRCUIT	番号	接点部 金めっき厚 CONTACT GOLD PLATING THICKNESS
6	FLASH	
7	0.38 micro-meters MIN	

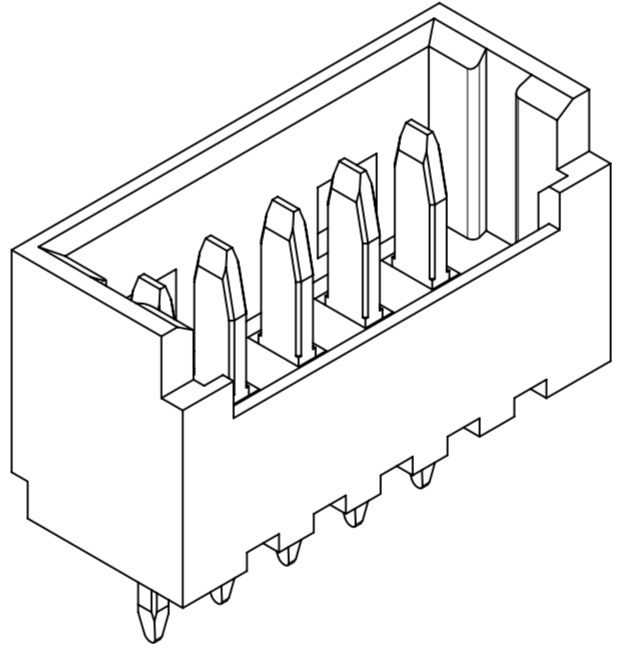
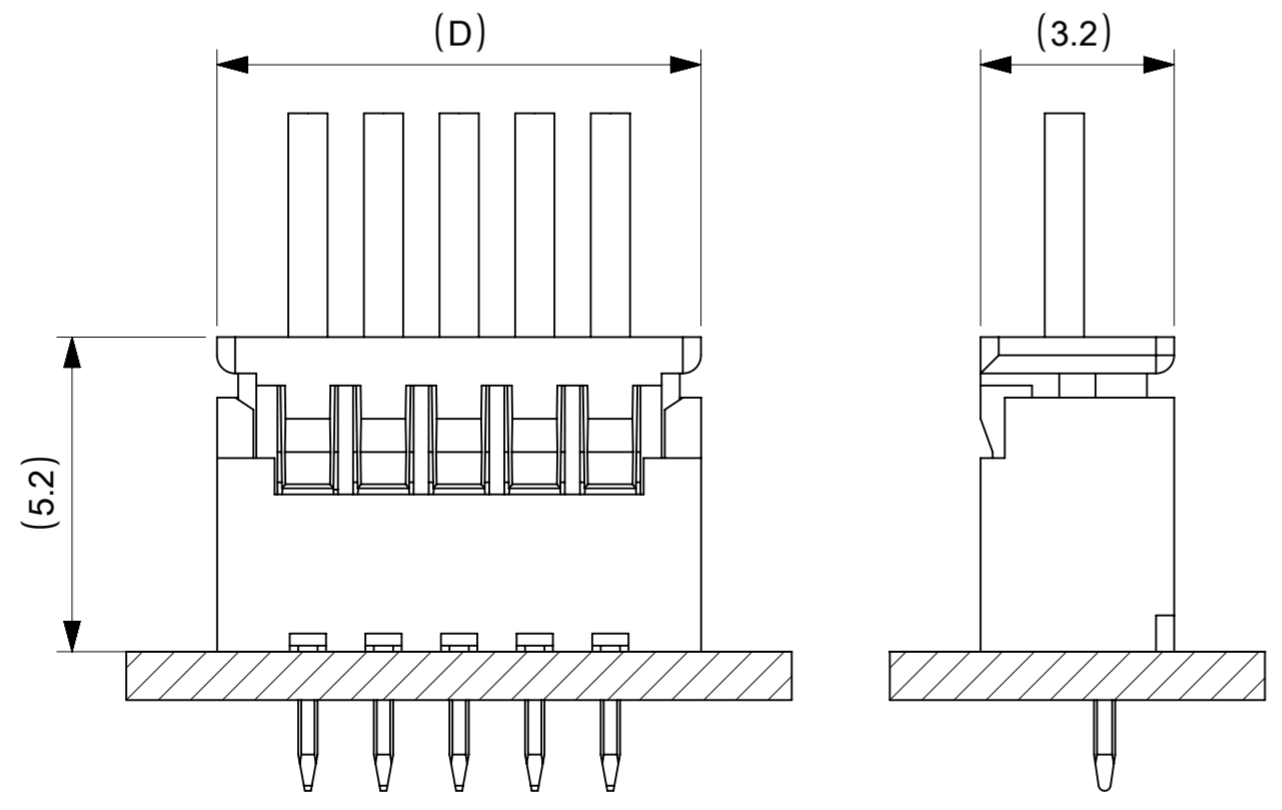
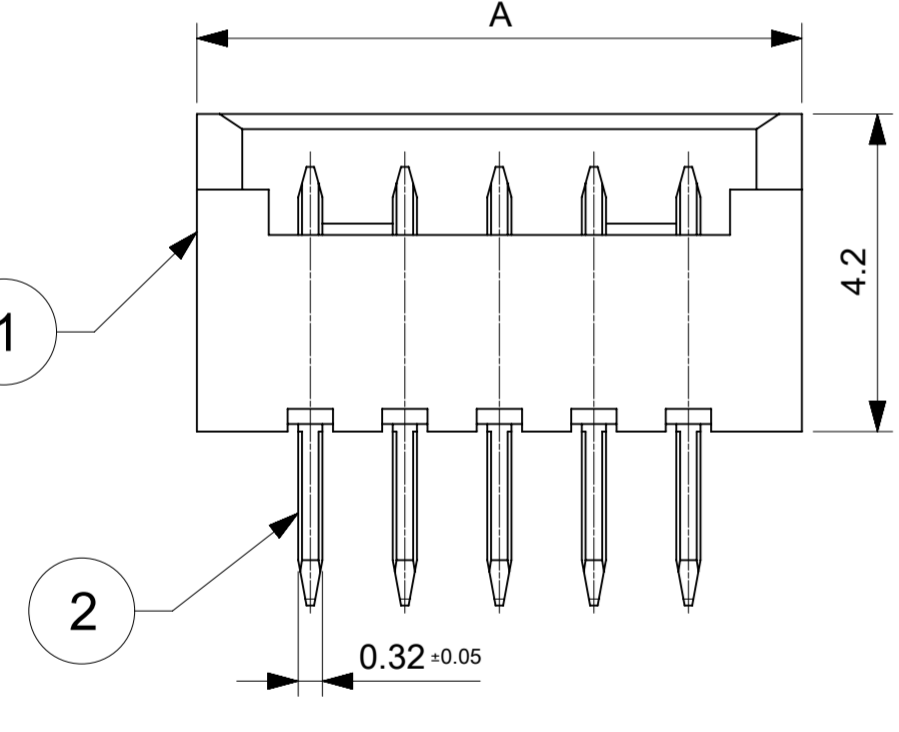

20.5	19.3	17.5	20.5	530471570	530471560	15
19.25	18.05	16.25	19.25	530471470	530471460	14
18	16.8	15	18	530471370	530471360	13
16.75	15.55	13.75	16.75	530471270	530471260	12
15.5	14.3	12.5	15.5	530471170	530471160	11
14.25	13.05	11.25	14.25	530471070	530471060	10
13	11.8	10	13	530470970	530470960	9
11.75	10.55	8.75	11.75	530470870	530470860	8
10.5	9.3	7.5	10.5	530470770	530470760	7
9.25	8.05	6.25	9.25	530470670	530470660	6
8	6.8	5	8	530470570	530470560	5
6.75	5.55	3.75	6.75	530470470	530470460	4
5.5	4.3	2.5	5.5	530470370	530470360	3
4.25	3.05	1.25	4.25	530470270	530470260	2

△2 TABLE1

番号 NO.	部品 PART	材質 MATERIAL
①	ハウジング HOUSING	ポリアミド(PA), UL94V-0, GLASS-FILLED, 色: ナチュラル(ホワイト) POLYAMIDE(PA), UL94V-0, GLASS-FILLED, COLOR: NATURAL (WHITE)
②	母材 MATERIAL	りん青銅 PHOSPHOR BRONZE
	コンタクト部 CONTACT AREA	金めっき : めっき厚は注記5参照 GOLD PLATING PLATING THICKNESS : SEE NOTE 5.
	テール部 TAIL AREA	無光沢錫めっき 1.0 micro-meters MIN MATTE TIN PLATING 1.0 micro-meters MIN
	下地めっき UNDER PLATING	ニッケルめっき 1.0 micro-meters MIN NICKEL PLATING 1.0 micro-meters MIN

嵌合図 MATED CONNECTORES

THIS DRAWING CONTAINS INFORMATION THAT IS PROPRIETARY TO MOLEX ELECTRONIC TECHNOLOGIES, LLC AND SHOULD NOT BE USED WITHOUT WRITTEN PERMISSION

DIMENSION UNITS	SCALE	CURRENT REV DESC:	molex			
mm	NTS					
GENERAL TOLERANCES (UNLESS SPECIFIED)			PICOBLADE 1.25 HEADER ASSY TH VERTICAL GOLD PLATING TYPE			
ANGULAR TOL	± 3.0°	EC NO: 738324	PRODUCT CUSTOMER DRAWING			
4 PLACES	± 0.2	DRWN: SSATO02 2023/01/12	DOCUMENT NUMBER			
3 PLACES	± 0.2	CHK'D: KOMURAKAMI 2023/04/20	DOC TYPE DOC PART REVISION			
2 PLACES	± 0.2	APPR: SAKIYAMA 2023/04/20	530470001-SD PSD 000 B			
1 PLACE	± 0.2	INITIAL REVISION:	MATERIAL NUMBER			
0 PLACES	± 0.2	DRWN: QHE31 2020/08/03	CUSTOMER			
		APPR: KOMURAKAMI 2021/05/27	SHEET NUMBER			
DRAFT WHERE APPLICABLE MUST REMAIN WITHIN DIMENSIONS	THIRD ANGLE PROJECTION	DRAWING	SERIES	MATERIAL NUMBER	CUSTOMER	SHEET NUMBER
		A2-SIZE	53047	SEE CHART	GENERAL	1 OF 2

△ 4 適合製品および各種仕様書
 APPLICABLE PRODUCTS AND SPECIFICATIONS

梱包仕様書 PACKING SPECIFICATION	PART NUMBER			SPECIFICATION NUMBER	
	53047****			SPK-53047-001	
適合嵌合相手 MATE WITH	HOUSING	CRIMP TERMINAL			
	51021****	WIRE SIZE (AWG)	GOLD PLATING THICKNESS		PART NUMBER
		#28-32	FLASH		500588020
			0.38 micro-meters		500588025
		#26-28	FLASH		500798020
0.38 micro-meters			500798025		
製品仕様書 PRODUCT SPECIFICATION	510210000-PS PS 001				
アプリケーション仕様書 (取扱説明書) APPLICATION SPECIFICATION	510210000-AS PS 000				

THIS DRAWING CONTAINS INFORMATION THAT IS PROPRIETARY TO MOLEX ELECTRONIC TECHNOLOGIES, LLC AND SHOULD NOT BE USED WITHOUT WRITTEN PERMISSION									
DIMENSION UNITS	SCALE	CURRENT REV DESC:			molex				
mm	NTS								
GENERAL TOLERANCES (UNLESS SPECIFIED)					PICOBLADE 1.25 HEADER ASSY TH VERTICAL GOLD PLATING TYPE				
ANGULAR TOL	± 3.0°	EC NO: 738324			PRODUCT CUSTOMER DRAWING				
4 PLACES	± 0.2	DRWN: SSATO02 2023/01/12			DOCUMENT NUMBER				
3 PLACES	± 0.2	CHK'D: KOMURAKAMI 2023/04/20			530470001-SD				
2 PLACES	± 0.2	APPR: SAKIYAMA 2023/04/20			DOC TYPE				
1 PLACE	± 0.2	INITIAL REVISION:			PSD				
0 PLACES	± 0.2	DRWN: QHE31 2020/08/03			DOC PART				
DRAFT WHERE APPLICABLE MUST REMAIN WITHIN DIMENSIONS		APPR: KOMURAKAMI 2021/05/27			REVISION				
THIRD ANGLE PROJECTION		DRAWING			SHEET NUMBER				
		A2-SIZE			2 OF 2				
		SERIES							
		53047							
		MATERIAL NUMBER							
		CUSTOMER							
		GENERAL							