

PART NUMBER	REV	TERMINATOR	FEED TYPE	DESCRIPTION
1339822-1	A	BENCH & LEADMAKER	MECH POST FEED	HDI APPLICATOR
7-1339822-1	A	BENCH & LEADMAKER	MECH POST FEED	-1 AND SPARE PARTS
7-1339822-7	A	-	-	SPARE PARTS KIT

LOC	DIST	REV	DATE	BY	APPV
A	66	A	15NOV2007	LJL	MC

CRIMP DATA ESCUBEDO TERMINAL TE CRIMP SPECS

CRIMP	SIZE	TYPE	RANGE
WIRE	1.78 [.070 IN]	F	0.50-1.00mm ² or 20-18 AWG
INSUL	3.05 [.120 IN]	F	1.80-2.50 [.071-.098 IN]

WIRE STRIP LENGTH 3.20-4.00 [.126-.157 IN]

APPL INSTRUCTIONS 408-8323

TERMINAL APPL SPEC	FEED
-	16.50 [.650 IN]

TERMINALS APPLIED

TE TERM PN	MANUF TERM PN	TE TERM PN	MANUF TERM PN
1949562-1	4408.00	1949562-5	4408.32
1949562-2	4408.02	-	-
1949562-3	4408.04	-	-
1949562-4	4408.30	-	-

WIRE SIZE	CRIMP HEIGHT	PIN PN & LENGTH [IN]
1.00mm ²	1.27 ±0.05 [.050 ±.002 IN]	1-354779-8 [.3080]
0.75mm ²	1.22 ±0.05 [.048 ±.002 IN]	2-354779-2 [.3100]
0.50mm ²	1.12 ±0.05 [.044 ±.002 IN]	3-354779-0 [.3140]

- RECOMMENDED SPARE PARTS
- 2. GREASE RAM, CAM, CAM FOLLOWER AND FEED ROD LIGHTLY.
- CERTAIN TERMINALS REQUIRE LUBRICATION. REFER TO THE APPLICATOR INSTRUCTION SHEET FOR MORE INFORMATION.
- 4. LUBRICATE DAILY PER THE APPLICATOR INSTRUCTION SHEET SUPPLIED WITH THE APPLICATOR.
- CRIMP DATA CALCULATED BY TYCO ELECTRONICS UK LTD.

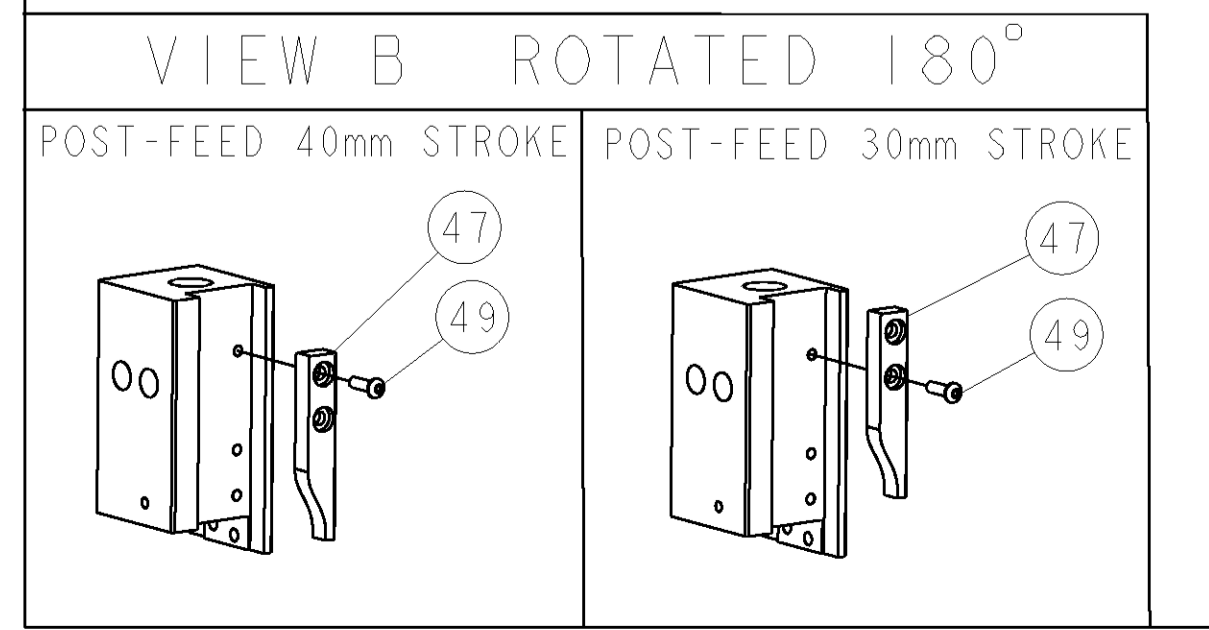
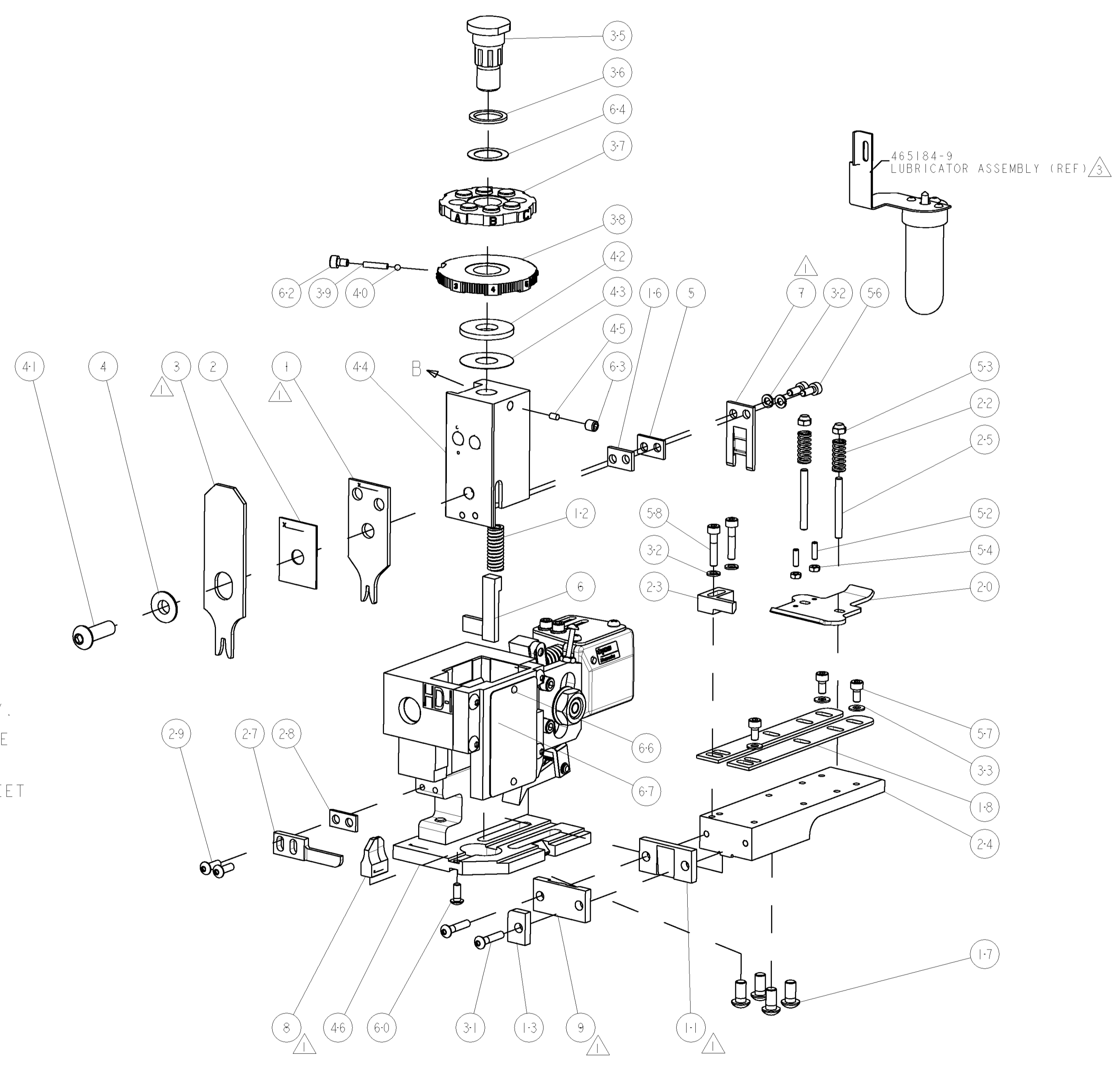

-	1	1	1338705-2	DOCUMENTATION PACKAGE	71	
-	1	1	461264-1	PLATE, IDENTIFICATION	67	
-	2	2	21017-2	SCREW, DRIVE	66	
-	1	1	986950-1	WASHER, FLAT PRECISION	64	
-	1	1	3-18031-0	SCR, SET, CUP POINT M6 X 6.0	63	
-	1	1	18023-9	SCR, SKT HD CAP M4 X 6.0	62	
-	1	1	18024-7	SCR, BTN SKT HD CAP (M4 X 10.0)	60	
-	2	2	1-18023-4	SCR, SKT HD CAP M4 X 20.0	58	
-	3	3	1-18023-0	SCR, SKT HD CAP M4 X 8.0	57	
-	2	2	1-18023-1	SCR, SKT HD CAP M4 X 10.0	56	
-	2	2	18029-1	NUT, HEX, REG M3	54	
-	2	2	986965-1	NUT, LOCK, HEX, TORQUE (M4)	53	
-	2	2	2-18032-2	SCR, SET, FLT POINT M3 X 10.0	52	
-	1	1	18024-3	SCR, BTN SKT HD CAP (M3 X 10.0)	49	
-	1	1	1338676-1	CAM, UNIVERSAL POST-FEED	47	
-	1	1	1338662-1	SUB ASSY, APPLICATOR FRAME	46	
-	1	1	690191-1	PLUG, NYLON	45	
-	1	1	1320998-1	RAM	44	
-	1	1	690125-1	SHIM SUB-ASSY	43	
-	1	1	690124-1	WASHER, RAM (.115)	42	
-	1	1	2-18024-6	SCR, BTN SKT HD CAP (M8 X 25.0)	41	
-	1	1	23241-1	BALL, STEEL	40	
-	1	1	2-22278-7	SPRING, COMPRESSION	39	
-	1	1	1320922-1	DISC, ADJUST, INSULATION CRIMP	38	
-	1	1	354777-1	WIRE DISC, ASSEMBLY	37	
-	1	1	22480-5	SPRING, COMPRESSION	36	
-	1	1	690212-1	POST, RAM	35	
-	3	3	18027-2	WASHER, FLAT, REG M4	33	
-	4	4	18025-2	WASHER, SPRG LOCK, REG M4	32	
-	2	2	1-18024-0	SCR, BTN SKT HD CAP (M4 X 20.0)	31	
-	2	2	18024-8	SCR, BTN SKT HD CAP (M4 X 12.0)	29	
-	1	1	3-690451-2	SPACER, STRIPPER	28	
-	1	1	240639-1	STRIPPER (MACHINING)	27	
-	2	2	1320906-1	STUD, THREADED	25	
-	1	1	1320995-1	PLATE, STRIP GUIDE	24	
-	1	1	240825-1	PLATE, STRIP HOLD DOWN	23	
-	2	2	4-22281-1	SPRING, DRAG	22	
-	1	1	1338665-1	DRAG	20	
-	2	2	1338663-7	GUIDE, LOWER STRIP	18	
-	4	4	1-18024-8	SCR, BTN SKT HD CAP (M6 X 12.0)	17	
-	1	1	1338708-1	SPACER, SLUG BLADE	16	
-	1	1	690481-2	SPACER, HOLD DOWN	13	
-	1	1	23846-1	SPRING, DIE	12	
-	1	1	240644-1	PLATE, REAR SHEAR	11	
-	-	-	-	-	10	
-	1	1	690482-4	PLATE, FRONT SHEAR	9	
-	1	2	2-1633384-5	ANVIL, COMBINATION	8	
-	1	1	690474-4	BLADE, SLUG	7	
-	1	1	2-455892-6	HOLD DOWN, TERMINAL	6	
-	1	1	4-240641-2	SPACER	5	
-	1	1	2-238009-7	BLOCK, FL CRIMPER SPACER	4	
-	1	2	1-456134-0	CRIMPER, INSULATION F PREMIUM	3	
-	1	1	455888-7	SPACER, CRIMPER	2	
-	1	2	4-456404-8	CRIMPER, WIRE PREMIUM	1	
-	77	71	-1	PART NO	DESCRIPTION	ITEM NO

DIMENSIONS: INCHES		TOLERANCES UNLESS OTHERWISE SPECIFIED:		DWN L LOFTHOUSE 24OCT2007	
0 PLC	±	1 PLC	±0.1	APVD M CLIFFORD 24OCT2007	NAME
1 PLC	±0.01	2 PLC	±0.001	Tyco Electronics Tyco Electronics Harrisburg, PA 17105-3608	
3 PLC	±0.001	4 PLC	±0.0001	END FEED HDI APPLICATOR	
4 PLC	±0.0001	ANGLES	±	SIZE CAGE CODE DRAWING NO RESTRICTED TO	
MATERIAL	FINISH	WEIGHT	SCALE	3:5	SHEET 1 OF 1 REV A
CUSTOMER DRAWING		SCALE 3:5		SHEET 1 OF 1 REV A	

CUSTOMER VIEWABLE ASSEMBLY