

## Evaluation Board for CS4349

### Features

- ◆ Stand-Alone or PC GUI Board Control
- ◆ CS8416 Receives S/PDIF-Compatible Digital Audio
- ◆ Headers for External PCM Audio Input
- ◆ Demonstrates Recommended Layout and Grounding Arrangements.
- ◆ Requires Only a Digital Signal Source and Power Supplies for a Complete Digital-to-Analog Converter System

### Description

The CDB4349 evaluation board is an excellent platform for quickly evaluating the CS4349 24-bit, 24-pin, stereo D/A converter. Evaluation requires an analog signal analyzer, a digital signal source, a PC for controlling the CS4349 (only required for Control Port Mode), and a power supply. Analog line-level outputs are provided via RCA phono jacks.

The CS8416 digital audio receiver IC provides the system timing necessary to operate the digital-to-analog converter and will accept S/PDIF-compatible audio data. The evaluation board may also be configured to accept external timing and data signals for operation in a user application during system development.

### ORDERING INFORMATION

CDB4349

Evaluation Board

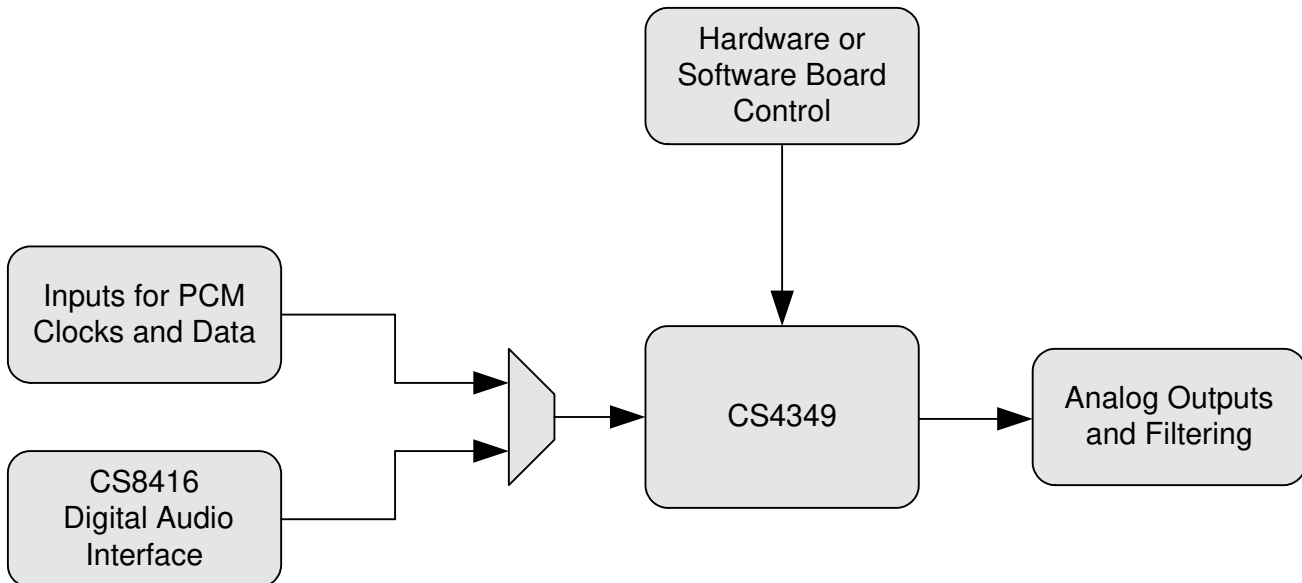

**TABLE OF CONTENTS**

<b>1. CDB4349 SYSTEM OVERVIEW .....</b>	<b>4</b>
<b>2. CS4349 DIGITAL-TO-ANALOG CONVERTER .....</b>	<b>4</b>
<b>3. CS8416 DIGITAL AUDIO RECEIVER .....</b>	<b>4</b>
<b>4. INPUT FOR CLOCKS AND DATA .....</b>	<b>4</b>
<b>5. INPUT FOR CONTROL DATA .....</b>	<b>4</b>
<b>6. POWER SUPPLY CIRCUITRY .....</b>	<b>5</b>
<b>7. GROUNDING AND POWER SUPPLY DECOUPLING .....</b>	<b>5</b>
<b>8. ANALOG OUTPUT FILTERING .....</b>	<b>5</b>
<b>9. BOARD CONNECTIONS AND SETTINGS .....</b>	<b>6</b>
<b>10. PERFORMANCE PLOTS .....</b>	<b>7</b>
<b>11. SCHEMATICS .....</b>	<b>13</b>
<b>12. LAYOUT .....</b>	<b>20</b>
<b>13. REVISION HISTORY .....</b>	<b>23</b>

**LIST OF FIGURES**

Figure 1. FFT 0 dBFS, FS = 48 kHz .....	7
Figure 2. FFT -60 dBFS, FS = 48 kHz .....	7
Figure 3. FFT No Input, FS = 48 kHz .....	7
Figure 4. FFT No Input Out of Band, FS = 48 kHz .....	7
Figure 5. Frequency Response 0 dBFS, FS = 48 kHz .....	7
Figure 6. THD+N vs Frequency 0 dBFS, FS = 48 kHz .....	7
Figure 7. THD+N vs Level 1 kHz, FS = 48 kHz .....	8
Figure 8. Fade-to-Noise Linearity 1 kHz, FS = 48 kHz .....	8
Figure 9. Impulse Response, FS = 48 kHz .....	8
Figure 10. FFT Crosstalk Ch. A to Ch. B 1 kHz, FS = 48 kHz .....	8
Figure 11. FFT Crosstalk Ch. B to Ch. A 1 kHz, FS = 48 kHz .....	8
Figure 12. FFT 0 dBFS, FS = 96 kHz .....	8
Figure 13. FFT -60 dBFS, FS = 96 kHz .....	9
Figure 14. FFT No Input, FS = 96 kHz .....	9
Figure 15. FFT No Input Out of Band, FS = 96 kHz .....	9
Figure 16. Frequency Response 0 dBFS, FS = 96 kHz .....	9
Figure 17. THD+N vs Frequency 0 dBFS, FS = 96 kHz .....	9
Figure 18. THD+N vs Level 1 kHz, FS = 96 kHz .....	9
Figure 19. Fade-to-Noise Linearity 1 kHz, FS = 96 kHz .....	10
Figure 20. Impulse Response, FS = 96 kHz .....	10
Figure 21. FFT Crosstalk Ch. A to Ch. B 1 kHz, FS = 96 kHz .....	10
Figure 22. FFT Crosstalk Ch. B to Ch. A 1 kHz, FS = 96 kHz .....	10
Figure 23. FFT 0 dBFS, FS = 192 kHz .....	10
Figure 24. FFT -60 dBFS, FS = 192 kHz .....	10
Figure 25. FFT No Input, FS = 192 kHz .....	11
Figure 26. FFT No Input Out of Band, FS = 192 kHz .....	11
Figure 27. Frequency Response 0 dBFS, FS = 192 kHz .....	11
Figure 28. THD+N vs Frequency 0 dBFS, FS = 192 kHz .....	11
Figure 29. THD+N vs Level 1 kHz, FS = 192 kHz .....	11
Figure 30. Fade-to-Noise Linearity 1 kHz, FS = 192 kHz .....	11
Figure 31. Impulse Response, FS = 192 kHz .....	12
Figure 32. FFT Crosstalk Ch. A to Ch. B 1 kHz, FS = 192 kHz .....	12
Figure 33. FFT Crosstalk Ch. B to Ch. A 1 kHz, FS = 192 kHz .....	12
Figure 34. System Block Diagram and Signal Flow .....	13
Figure 35. CS4349 .....	14
Figure 36. Analog Outputs .....	15
Figure 37. PCM Input Header and Hardware Control .....	16

---

Figure 38. CS8416 S/PDIF Input .....	17
Figure 39. Control Port .....	18
Figure 40. Power .....	19
Figure 41. Silkscreen Top .....	20
Figure 42. Top Side .....	21
Figure 43. Bottom Side .....	22

**LIST OF TABLES**

Table 1. System Connections .....	6
Table 2. CDB4349 Jumper Settings .....	6
Table 3. CDB4349 Switch Settings .....	6

---

## 1. CDB4349 SYSTEM OVERVIEW

The CDB4349 evaluation board is an excellent platform for quickly evaluating the CS4349. The CS8416 digital audio interface receiver provides an easy interface to digital audio signal sources including the majority of digital audio test equipment. The evaluation board also allows the user to supply external PCM clocks and data through headers for system development.

The CDB4349 schematic has been partitioned into 6 pages, shown in [Figures 35 through 40](#). Each schematic page is represented in the system diagram shown in [Figure 34](#). Notice that the system diagram also includes the interconnections between the partitioned schematics.

## 2. CS4349 DIGITAL-TO-ANALOG CONVERTER

A description of the CS4349 is included in the CS4349 datasheet, available at <http://www.cirrus.com/en/products/pro/detail/P1116.html>.

## 3. CS8416 DIGITAL AUDIO RECEIVER

The system receives and decodes the standard S/PDIF data format using a CS8416 digital audio receiver ([Figure 38](#)). The outputs of the CS8416 include a serial bit clock, serial data, and a left-right clock. The CS8416 data format is selected through switch S1. The operation of the CS8416 and a discussion of the digital audio interface is included in the CS8416 datasheet, available at <http://www.cirrus.com/en/products/pro/detail/P1005.html>.

The CDB4349 has been designed so that the input can be either optical or coaxial (see [Figure 39](#)). However, both inputs cannot be driven simultaneously.

After the CS8416 serial format is changed either through S1 in Stand-Alone Mode, or through the CDB4349 GUI in PC Mode, a reset is required. The CS8416 can be manually reset using 'HARDWARE RESET' (S2) in Stand-Alone Mode, or through software when operating the CDB4349 in PC Mode.

## 4. INPUT FOR CLOCKS AND DATA

The evaluation board has been designed to allow external PCM data input through header J10. The schematic for the clock/data input is shown in [Figure 37](#). In Stand-Alone Mode, switch position 6 of S4 selects the source as either CS8416 (open) or header J10 (closed). In PC Mode, the PCM source is selected through software.

## 5. INPUT FOR CONTROL DATA

The evaluation board can be run in either a Stand-Alone Mode or with a PC. Stand-Alone Mode does not require the use of a PC, and the mode pins are configured using switch positions 1 through 5 of S4 and switch positions 1 and 2 of S1. PC Mode uses software to set up the CS4349 through I<sup>2</sup>C<sup>®</sup> or SPI<sup>™</sup> interface using the PC's serial port or USB port. When the serial port (RS232) or USB is attached and the CDB4349 software is running, PC Mode is automatically selected.

Header J38 offers the option for external input of RST and SPI/I<sup>2</sup>C clocks and data. The board is set up from the factory to use the on-board microcontroller in conjunction with software available at <http://www.cirrus.com/en/products/software/msaudio.html>. To use an external control source, remove the shunts on J38 and place a ribbon cable so the signal lines are on the center row and the grounds are on the right side. R89 and R90 should be populated with 2 k $\Omega$  resistors when using an external I<sup>2</sup>C source which does not already provide pull-ups.

---

## 6. POWER SUPPLY CIRCUITRY

Power is supplied to the evaluation board by three binding posts (GND, +12V, and -12V), as shown in [Figure 40](#). The '+12V' and '-12V' terminals supply the active output filters. The +3.3 V and +5.0 V circuitry is powered by regulators fed by the '+12V' terminal. Headers J3, J4, and J7 allow the user to either select +3.3 V or +5.0 V supplies for the various CS4349 voltage supply pins. Alternatively, the user can remove the shunts on J3, J4, and J7, and provide an external power supply.

**WARNING:** Refer to the CS4349 datasheet for maximum allowable voltage levels. Operation outside of this range can cause permanent damage to the device.

## 7. GROUNDING AND POWER SUPPLY DECOUPLING

As with any high-performance converter, the CS4349 requires careful attention to power supply and grounding arrangements in order to optimize performance. [Figure 35](#) details the connections to the CS4349 while [Figures 41](#), [42](#), and [43](#) show the component placement and top and bottom layout. The decoupling capacitors are located as close to the CS4349 as possible. Extensive use of ground plane fill in the evaluation board yields large reductions in radiated noise.

## 8. ANALOG OUTPUT FILTERING

The passive output filter on the CDB4349 has been designed according to the CS4349 datasheet.

## 9. BOARD CONNECTIONS AND SETTINGS

Board connections and settings are shown in [Table 1](#), [Table 2](#), and [Table 3](#).

CONNECTOR	INPUT/OUTPUT	SIGNAL PRESENT
GND	Input	Ground connection from power supply
+12V	Input	+12 V positive supply for the on-board filtering
-12V	Input	-12 V negative supply for the on-board filtering
S/PDIF IN - J1	Input	Digital audio interface input via coax
S/PDIF IN - OPT1	Input	Digital audio interface input via optical
PCM INPUT - J10	Input	Input for master, serial, left/right clocks and serial data
POUTA, POUTB	Output	RCA line level analog outputs from passive output stage

**Table 1. System Connections**

JUMPER	PURPOSE	POSITION	FUNCTION SELECTED
J3, J4, J7	Selects Supply Voltage for CS4349	+5V *+3.3V	Supplies +5.0 V to associated CS4349 supply *Supplies +3.3 V to associated CS4349 supply
J38	Selects source of control data	*PC CONTROL shunts removed	*Control from PC and on-board microcontroller External control input using center and right columns
J27	C2 micro programming	-	Reserved for factory use only

**Table 2. CDB4349 Jumper Settings**

\*Default Factory Settings.

SWITCH (Note 1)	PURPOSE	POSITION	FUNCTION SELECTED
S2	Resets CS8416 and CS4349		The CS8416 must be reset if switch S1 is changed
S1	CS8416 Format Select SFSEL[1:0]	1, 2	Default: SFSEL[1:0] = 00 (Closed). See CS8416 datasheet for details.
S4	CS4349 Format Select DIF[2:0]	1, 2, 3	Default: DIF[2:0] = 000 (Closed). See CS4349 datasheet for details.
	CS4349 De-emphasis Select	4	open = De-emphasis enabled *closed = De-emphasis disabled.
	CS4349 Popguard® Enable	5	open = Popguard enabled *closed = Popguard disabled.
	Selects PCM source for CS4349	6	*open = CS8416 closed = PCM Header J10

**Table 3. CDB4349 Switch Settings**

\*Default Factory Settings.

**Note:**

1. Switch settings take effect in Stand-Alone Mode only.

## 10.PERFORMANCE PLOTS

Test conditions (unless otherwise specified):  $T_A = 25^\circ\text{C}$ ; Measurement bandwidth is 20 Hz to 20 kHz (unweighted);  $V_A = 5\text{ V}$ ;  $V_{LC} = V_{LS} = 3.3\text{ V}$ ; Input signal is a 0 dBFS 1 kHz sine wave; Input data resolution is 24 bits, Left-Justified; Channel A output = blue traces; Channel B output = green traces.

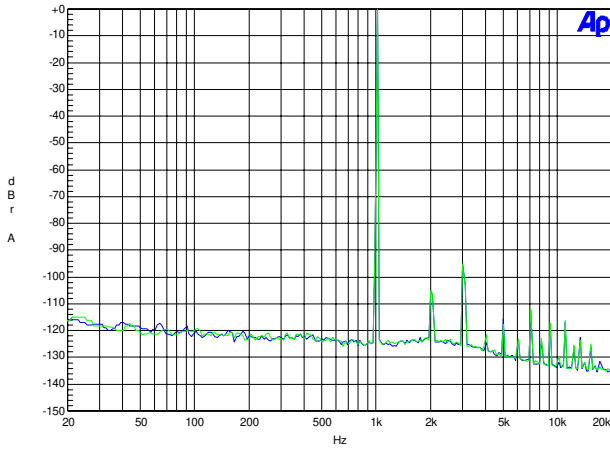

Figure 1. FFT 0 dBFS, FS = 48 kHz

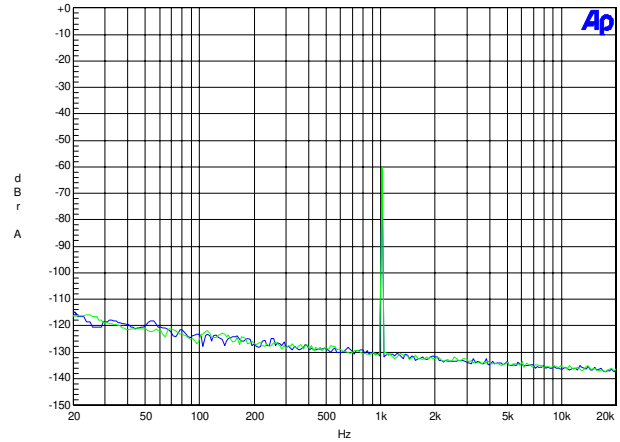

Figure 2. FFT -60 dBFS, FS = 48 kHz

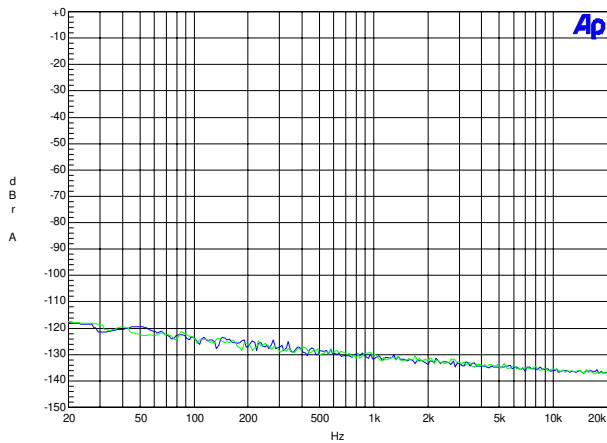

Figure 3. FFT No Input, FS = 48 kHz

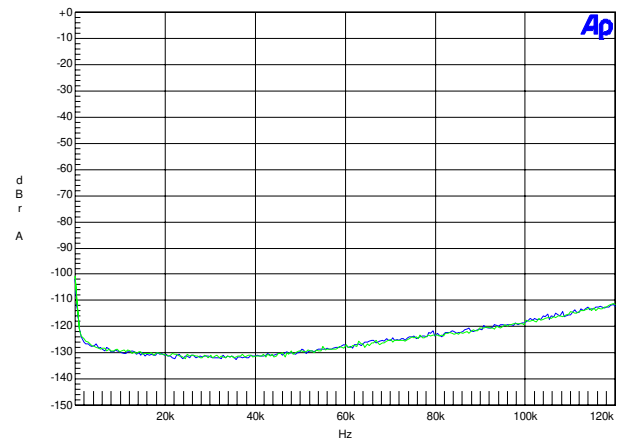

Figure 4. FFT No Input Out of Band, FS = 48 kHz

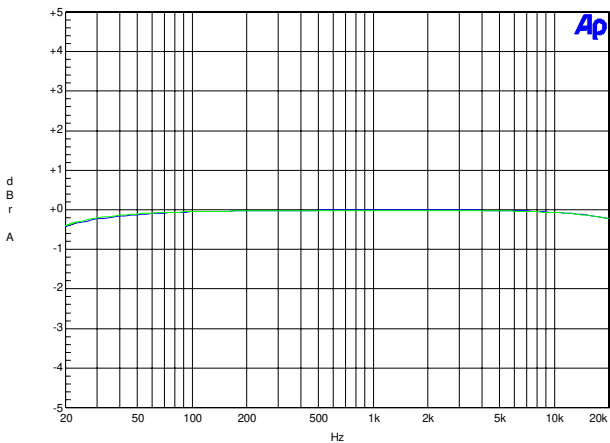

Figure 5. Frequency Response 0 dBFS, FS = 48 kHz

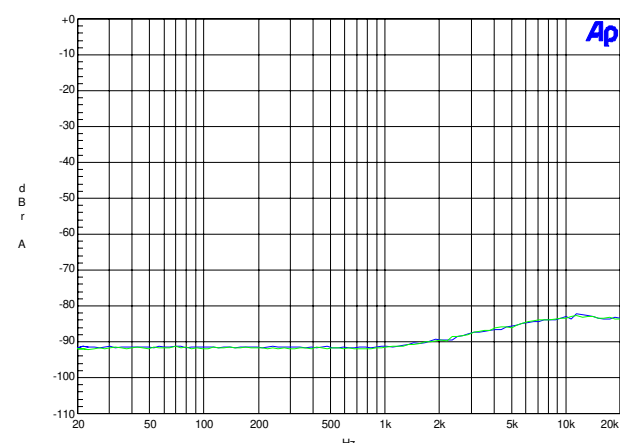
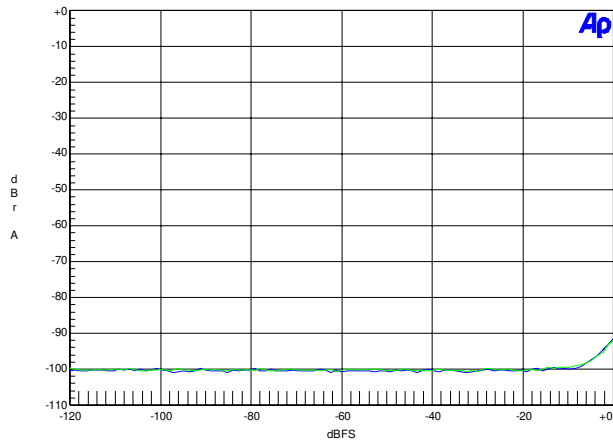
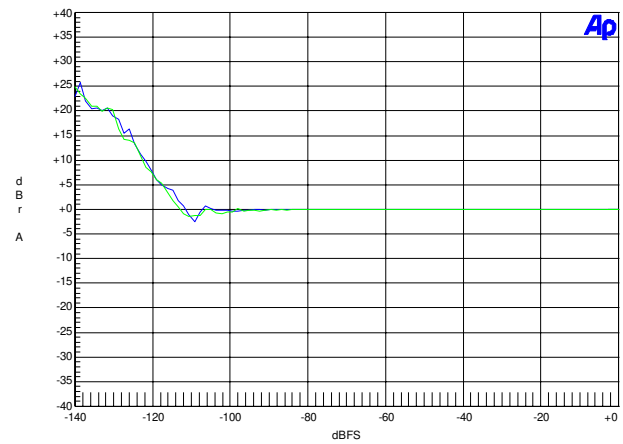
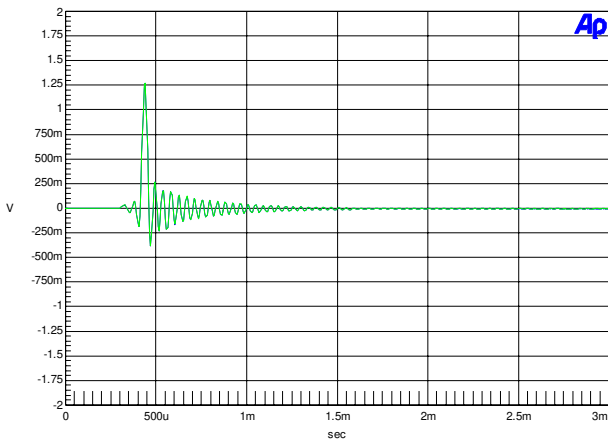
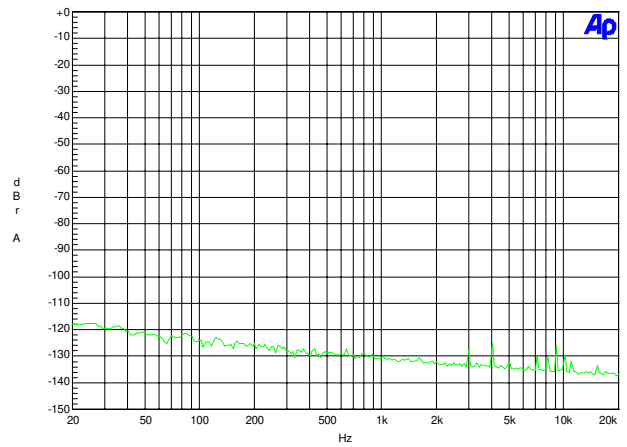
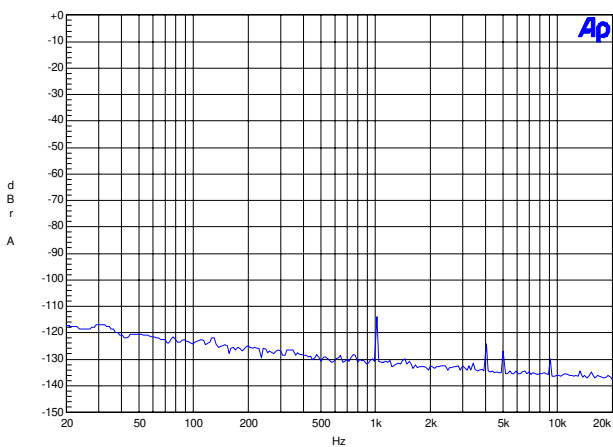
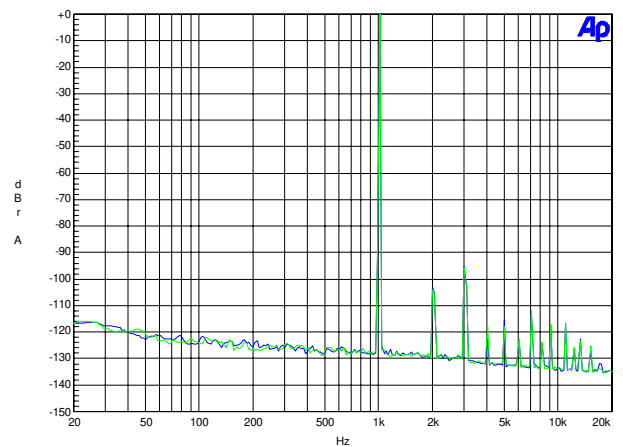
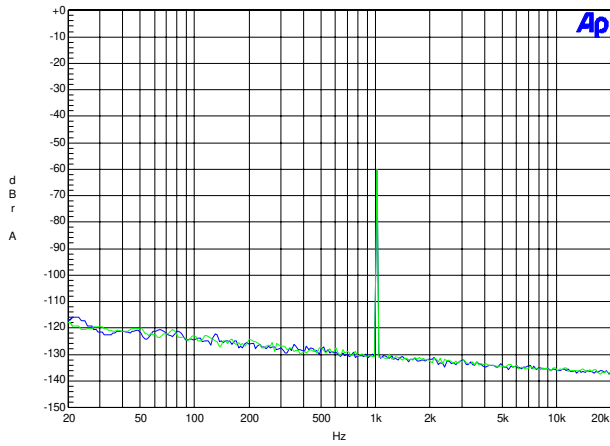
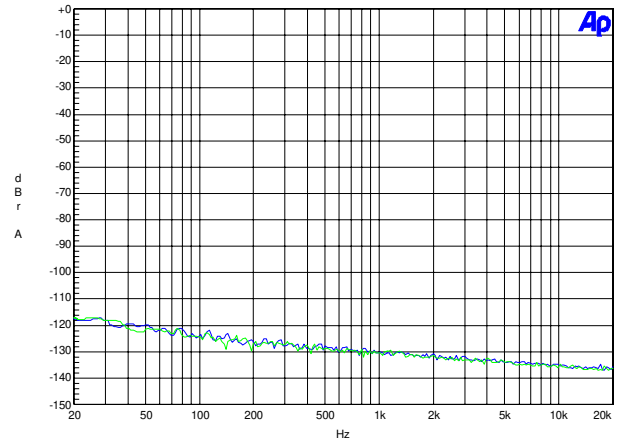
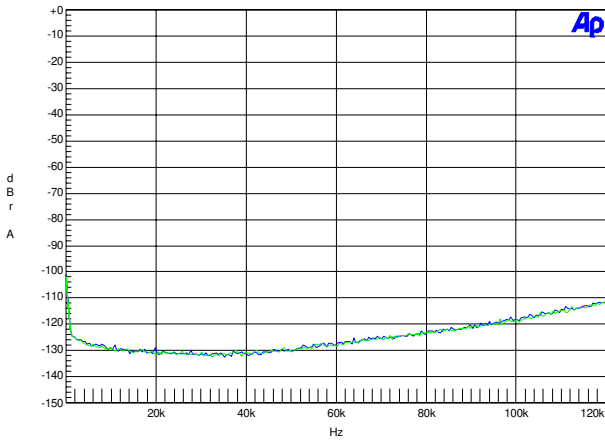
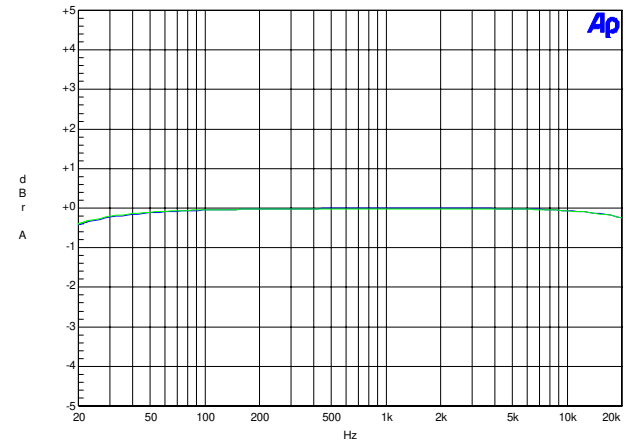
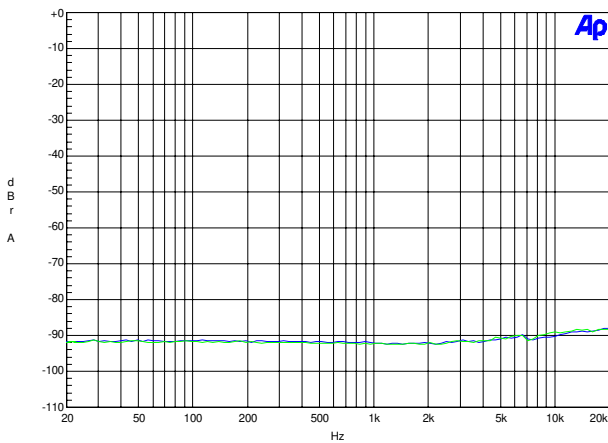
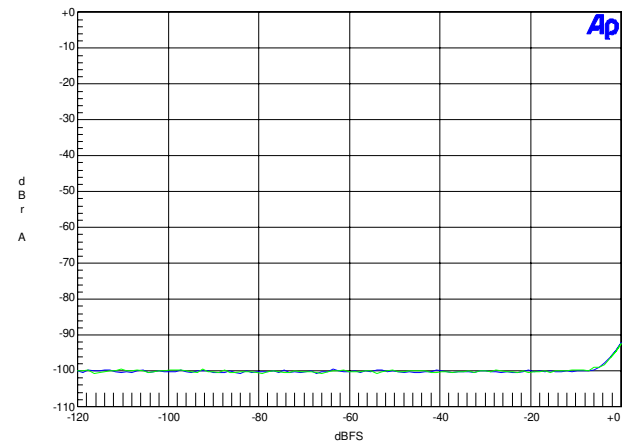
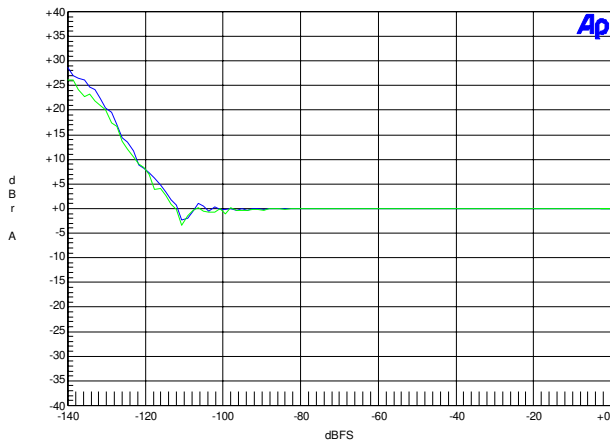
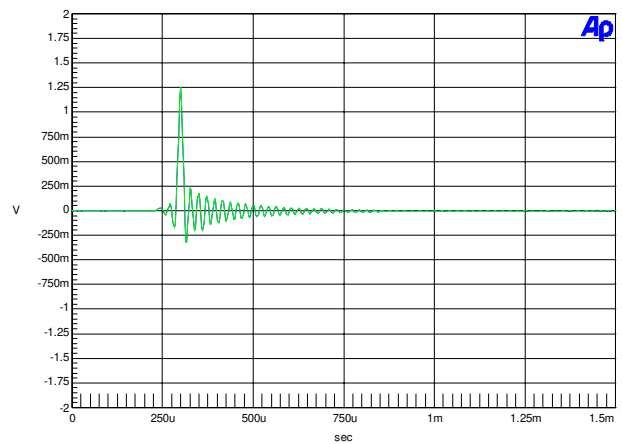
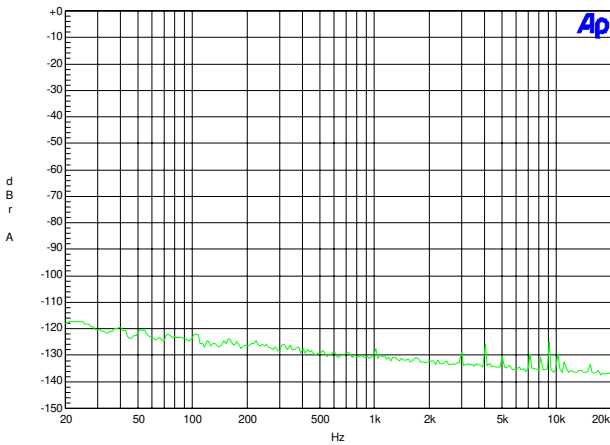
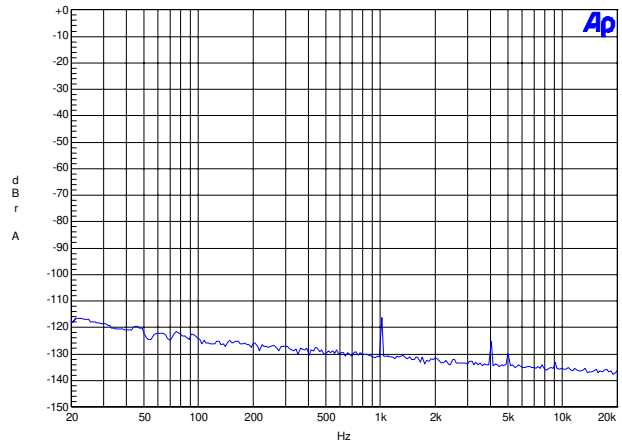
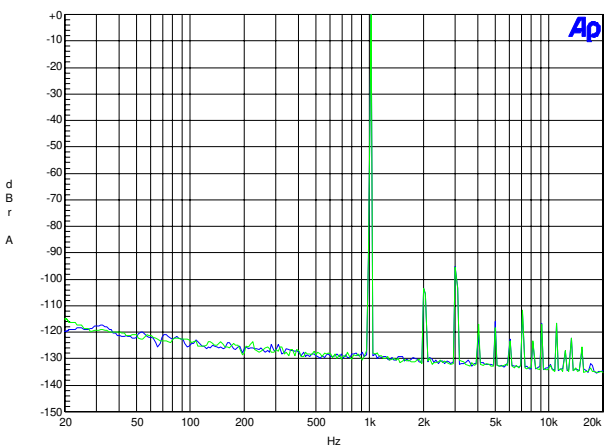
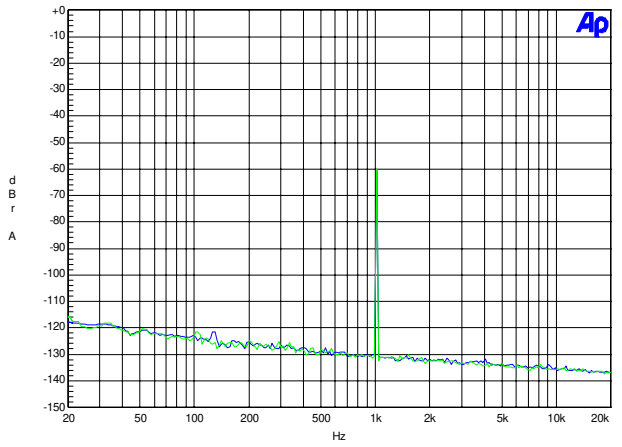

Figure 6. THD+N vs Frequency 0 dBFS, FS = 48 kHz

**Figure 7. THD+N vs Level 1 kHz, FS = 48 kHz**

**Figure 8. Fade-to-Noise Linearity 1 kHz, FS = 48 kHz**

**Figure 9. Impulse Response, FS = 48 kHz**

**Figure 10. FFT Crosstalk Ch. A to Ch. B 1 kHz, FS = 48 kHz**

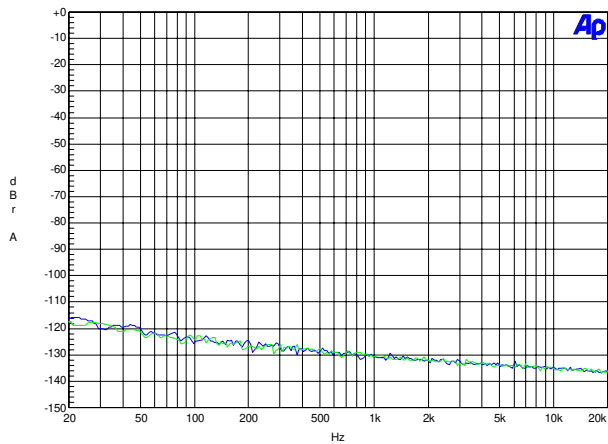
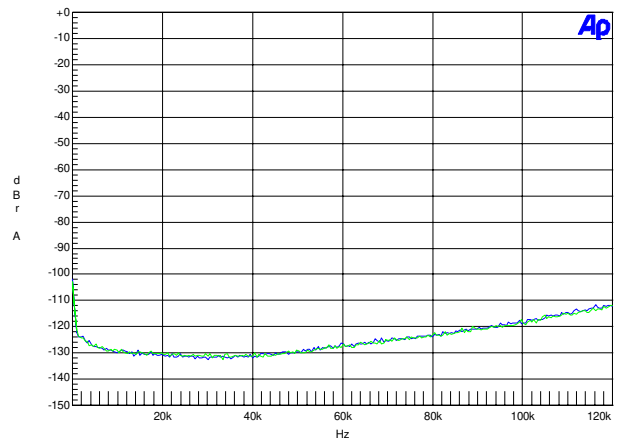
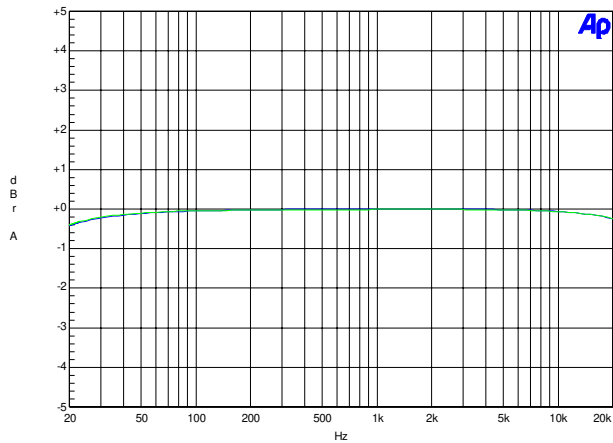
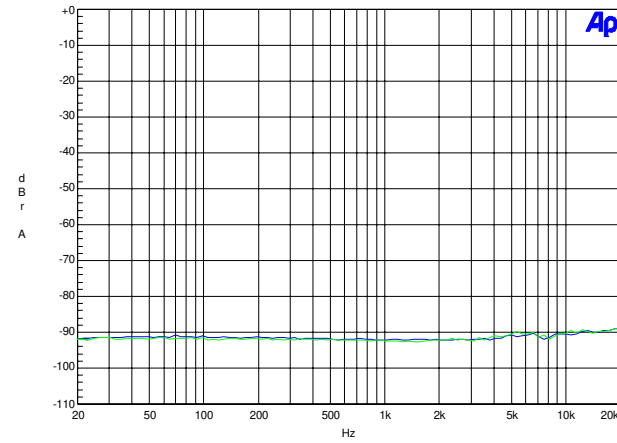
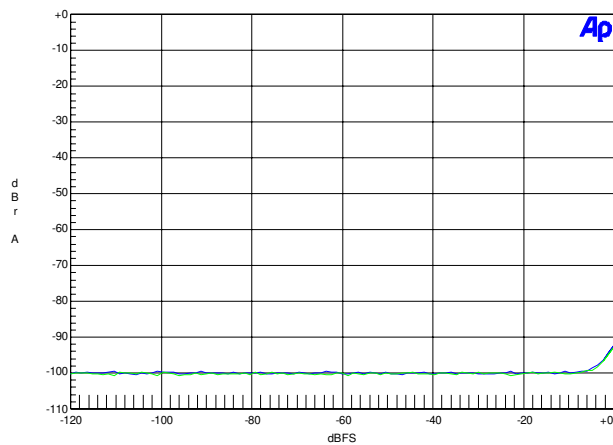
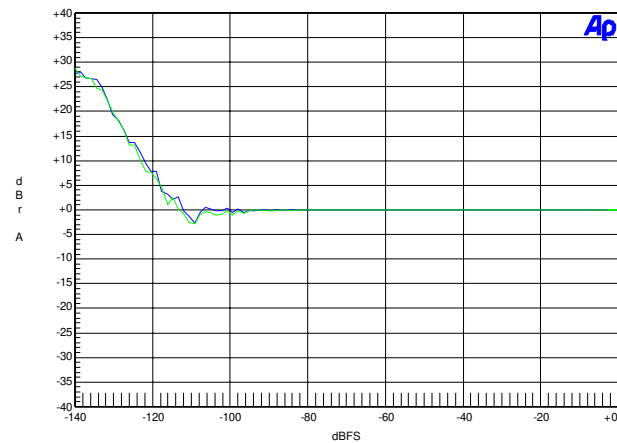
**Figure 11. FFT Crosstalk Ch. B to Ch. A 1 kHz, FS = 48 kHz**

**Figure 12. FFT 0 dBFS, FS = 96 kHz**



**Figure 13. FFT -60 dBFS, FS = 96 kHz**

**Figure 14. FFT No Input, FS = 96 kHz**

**Figure 15. FFT No Input Out of Band, FS = 96 kHz**

**Figure 16. Frequency Response 0 dBFS, FS = 96 kHz**

**Figure 17. THD+N vs Frequency 0 dBFS, FS = 96 kHz**

**Figure 18. THD+N vs Level 1 kHz, FS = 96 kHz**

**Figure 19. Fade-to-Noise Linearity 1 kHz, FS = 96 kHz**

**Figure 20. Impulse Response, FS = 96 kHz**

**Figure 21. FFT Crosstalk Ch. A to Ch. B 1 kHz, FS = 96 kHz**

**Figure 22. FFT Crosstalk Ch. B to Ch. A 1 kHz, FS = 96 kHz**

**Figure 23. FFT 0 dBFS, FS = 192 kHz**

**Figure 24. FFT -60 dBFS, FS = 192 kHz**

**Figure 25. FFT No Input, FS = 192 kHz**

**Figure 26. FFT No Input Out of Band, FS = 192 kHz**

**Figure 27. Frequency Response 0 dBFS, FS = 192 kHz**

**Figure 28. THD+N vs Frequency 0 dBFS, FS = 192 kHz**

**Figure 29. THD+N vs Level 1 kHz, FS = 192 kHz**

**Figure 30. Fade-to-Noise Linearity 1 kHz, FS = 192 kHz**

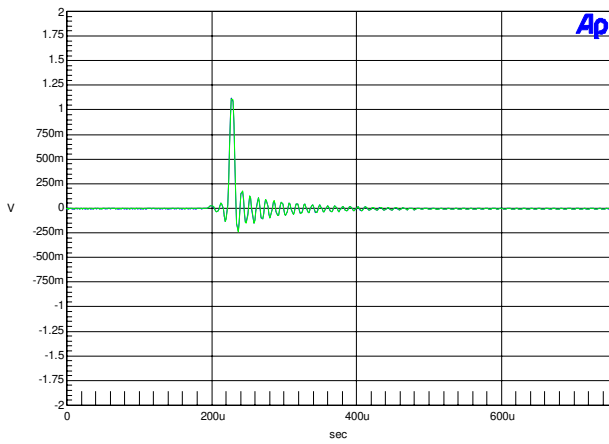

Figure 31. Impulse Response, FS = 192 kHz

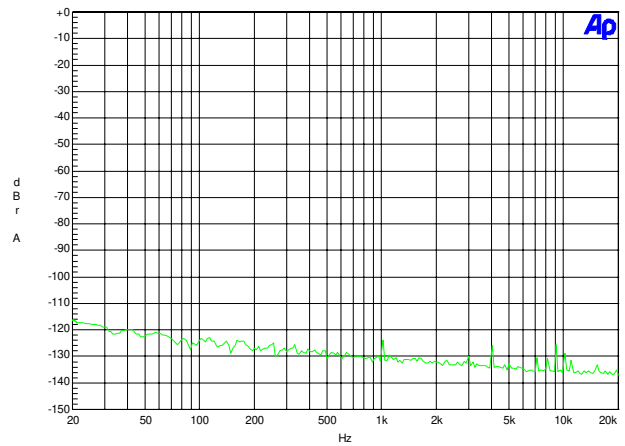

Figure 32. FFT Crosstalk Ch. A to Ch. B 1 kHz, FS = 192 kHz

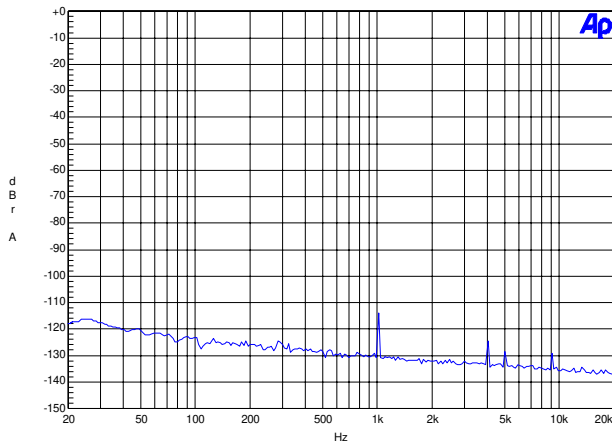

Figure 33. FFT Crosstalk Ch. B to Ch. A 1 kHz, FS = 192 kHz

# 11.SCHEMATICS

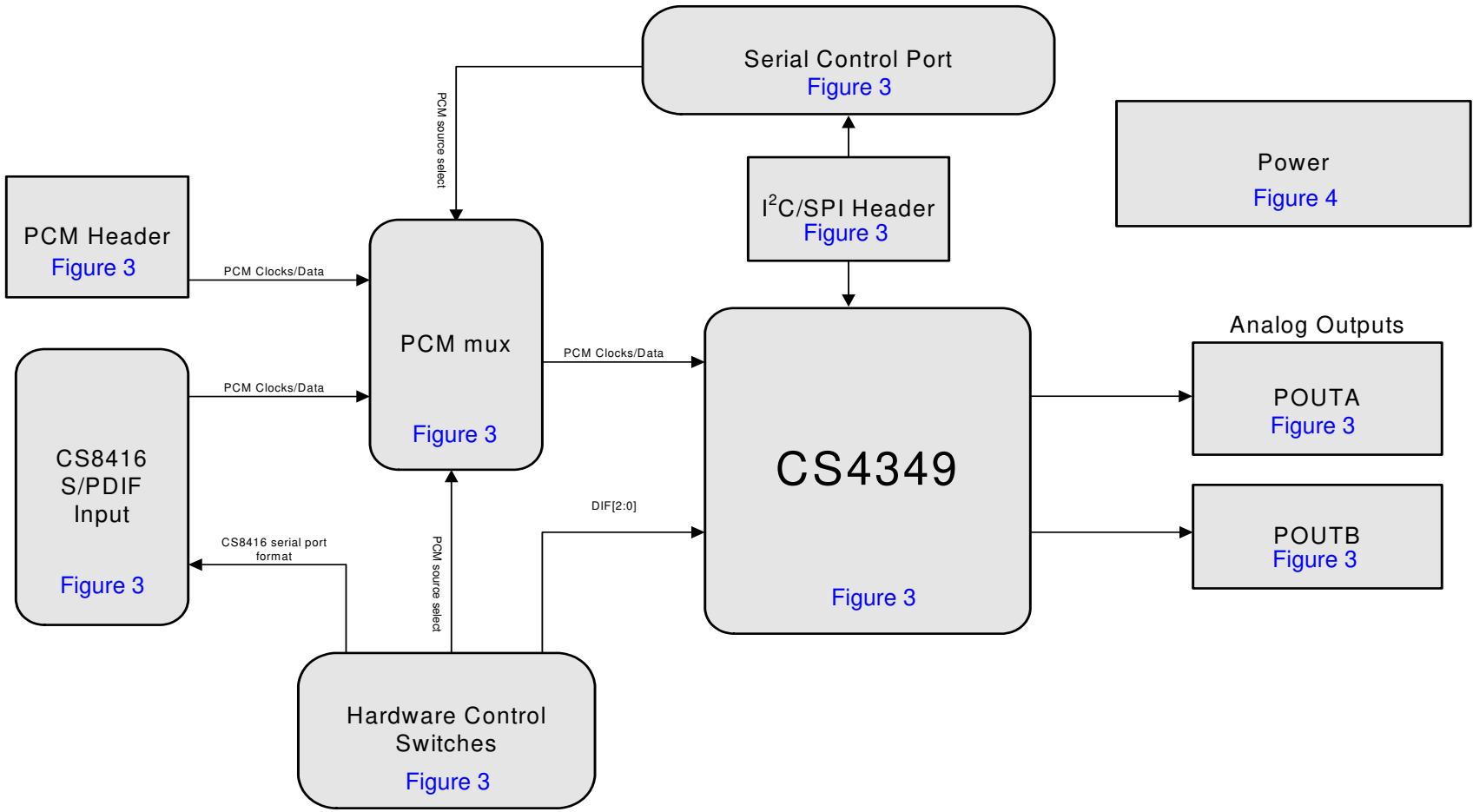

Figure 34. System Block Diagram and Signal Flow

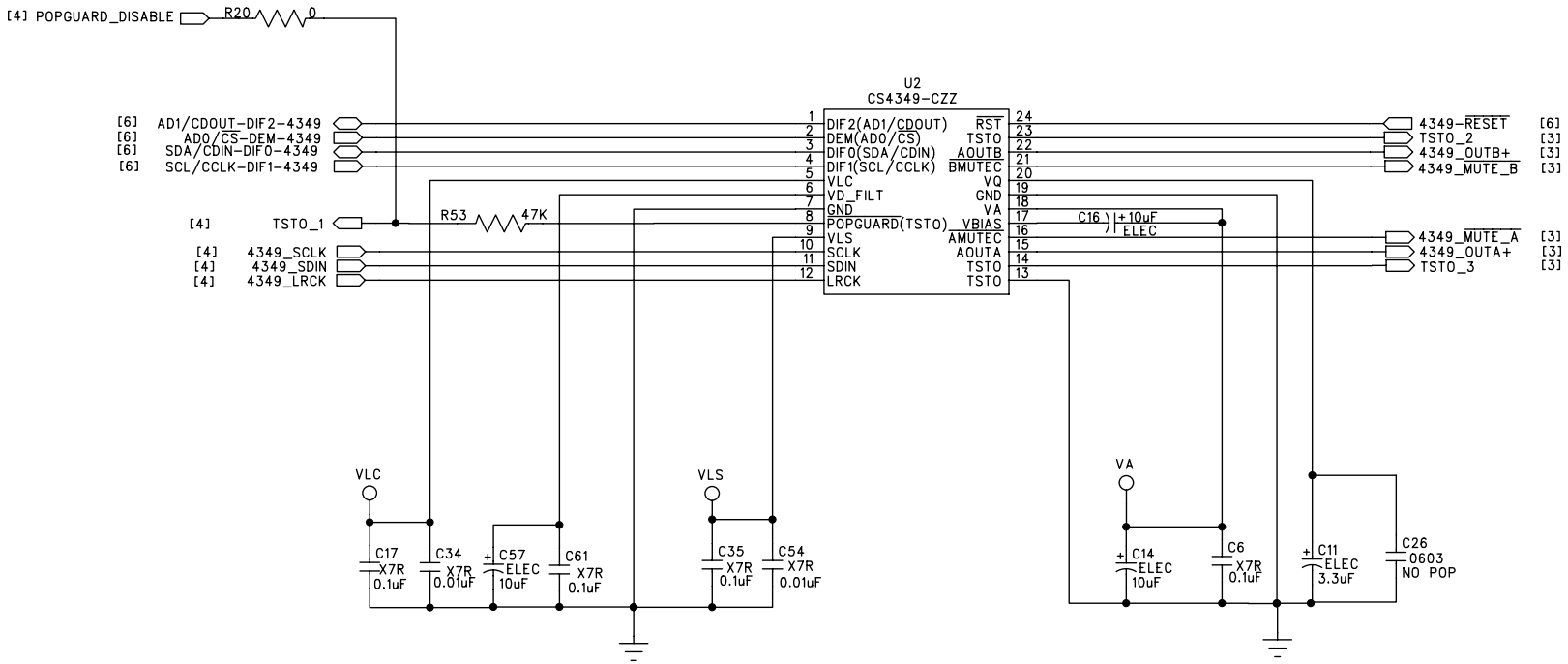

Figure 35. CS4349

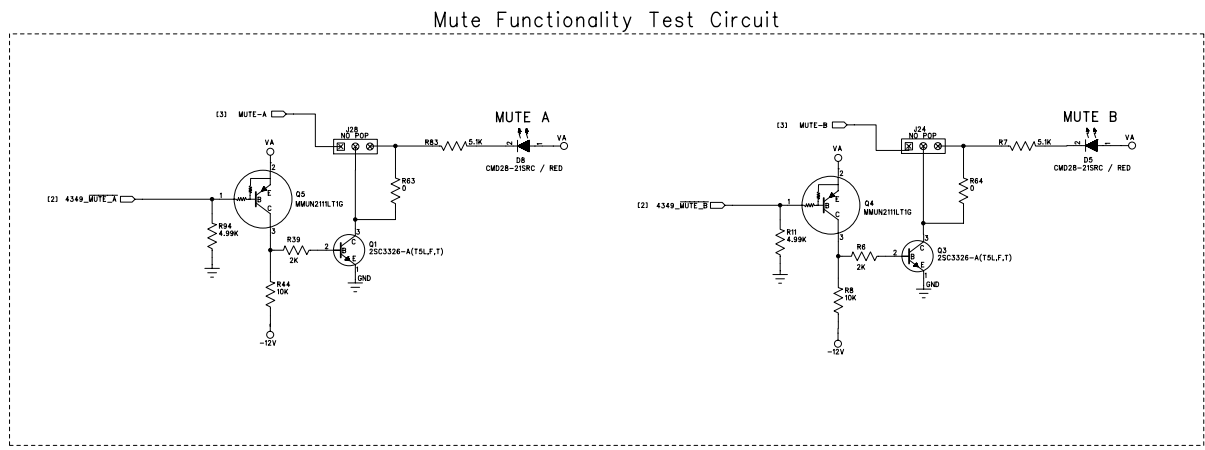
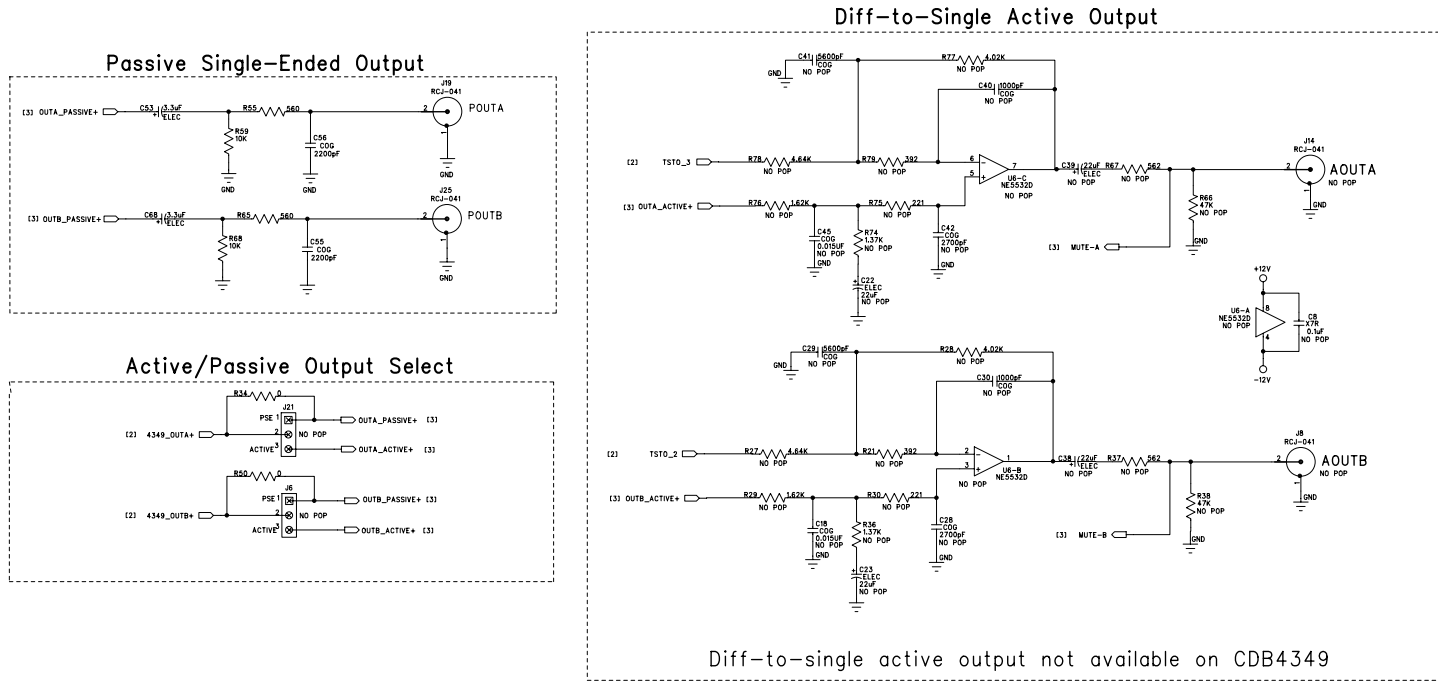
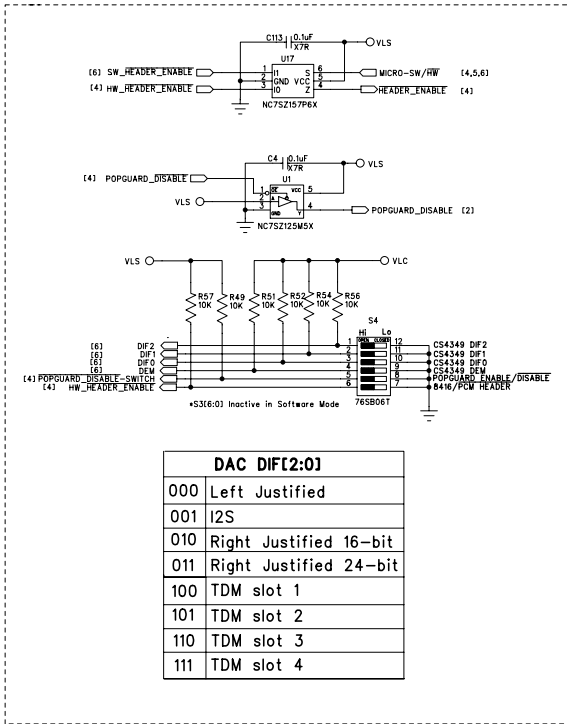
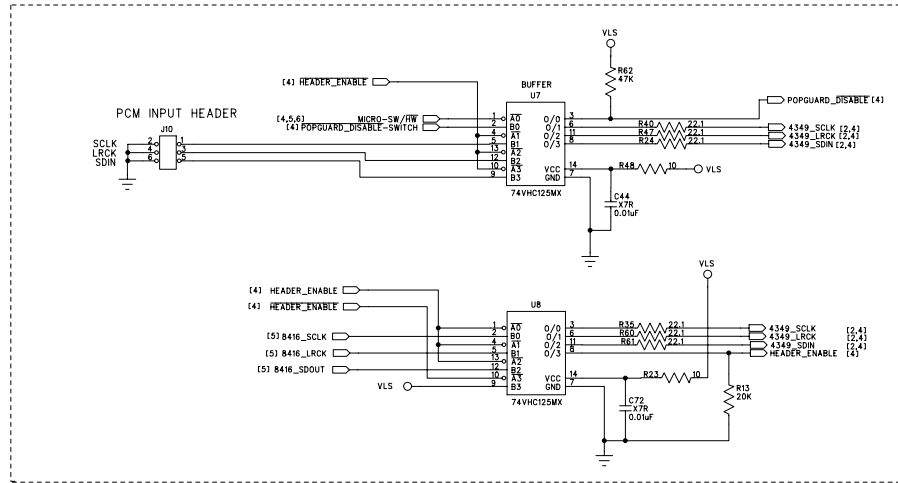

Figure 36. Analog Outputs

Control Signal Mux and Switch



PCM Input Header Clock/Data Mux and Level Shift



RMCK Output Header

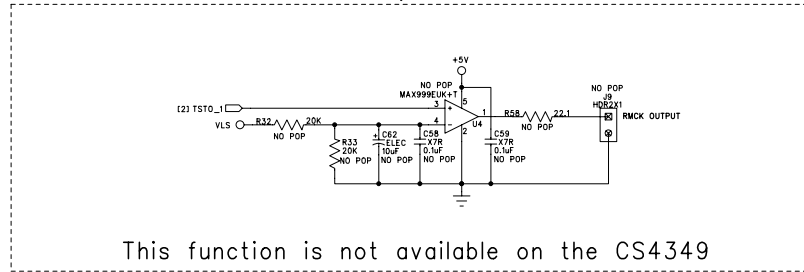
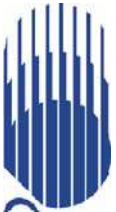
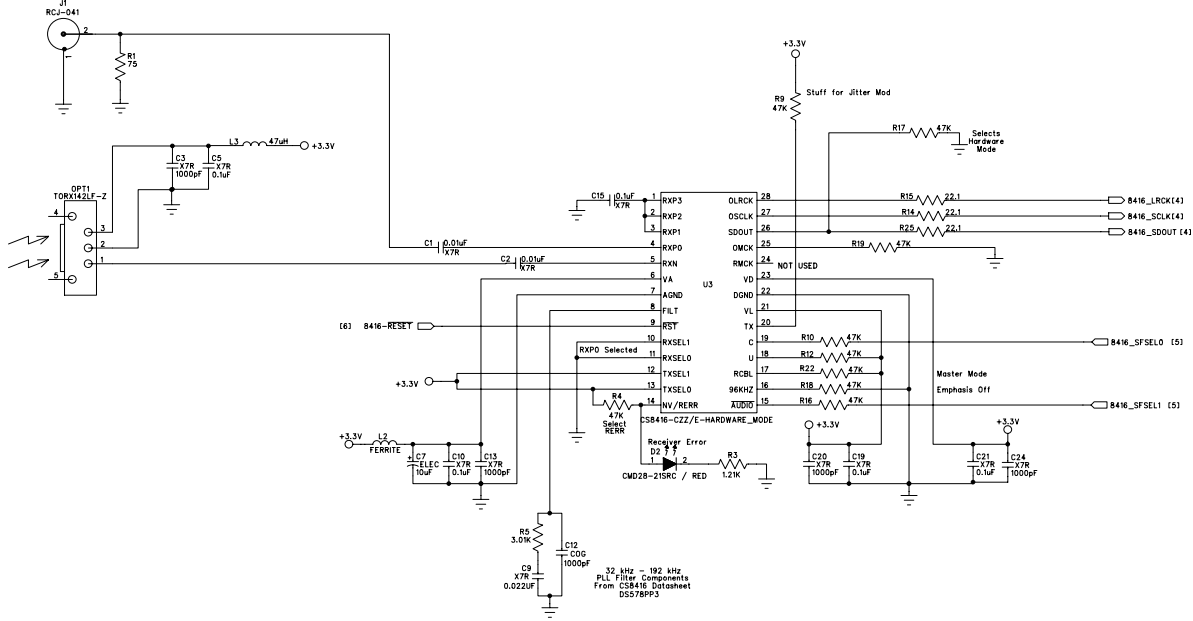

Figure 37. PCM Input Header and Hardware Control







CS8416 Serial Format Control

CS8416 SFSEL[1:0]	
00	Left Justified
01	I2S
10	Right Justified 24 Bit
11	Invalid

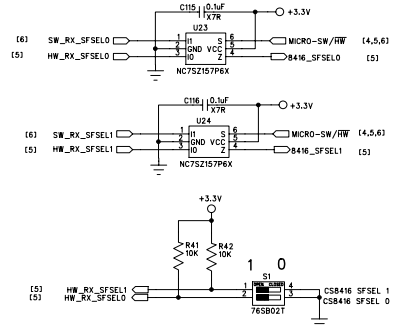

Figure 38. CS8416 S/PDIF Input

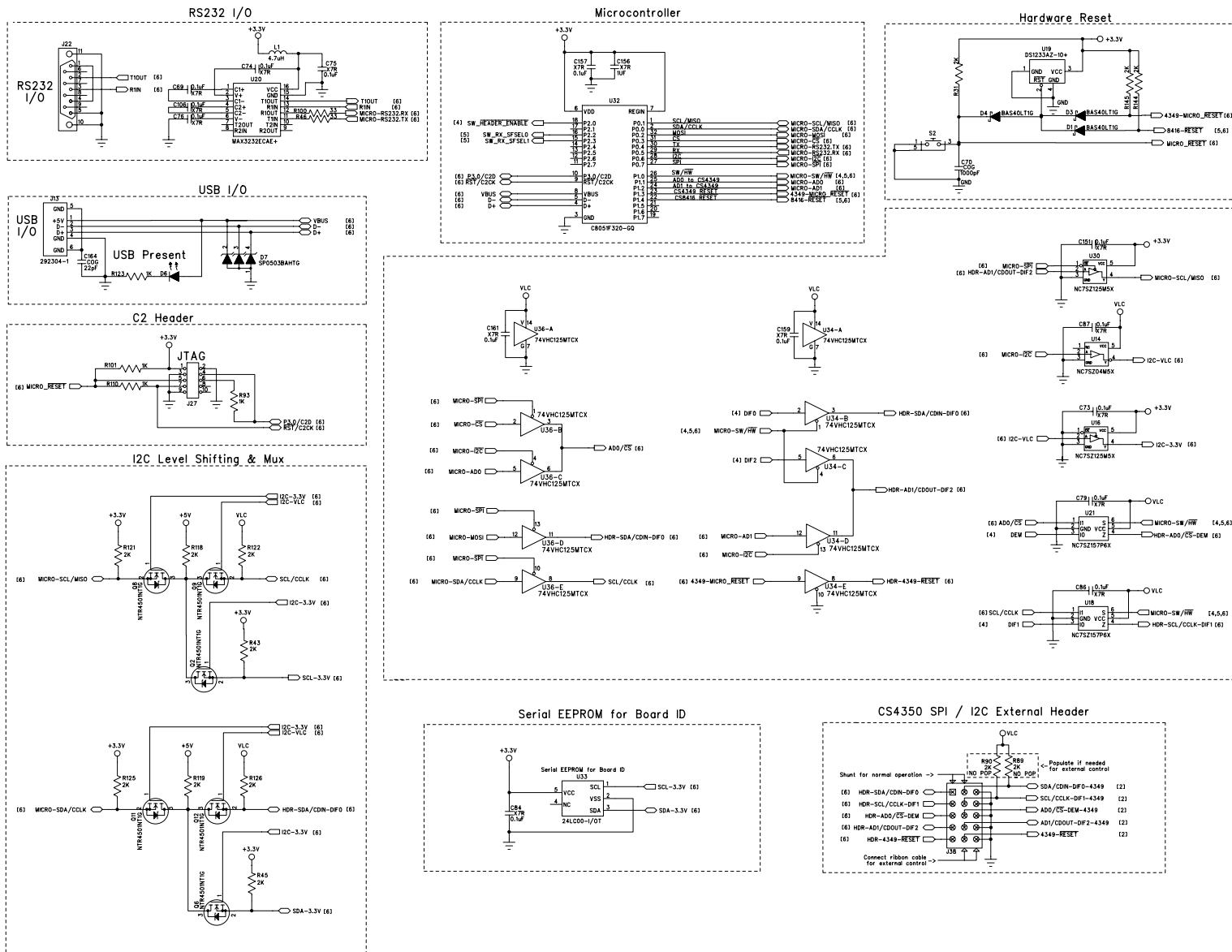
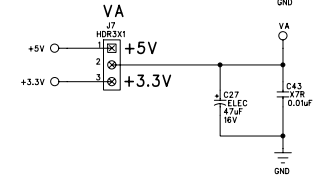
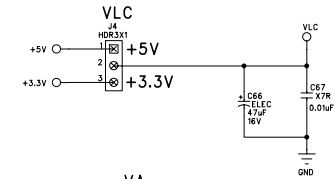
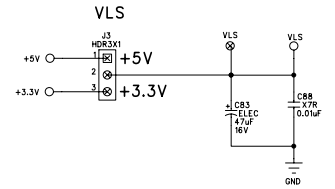
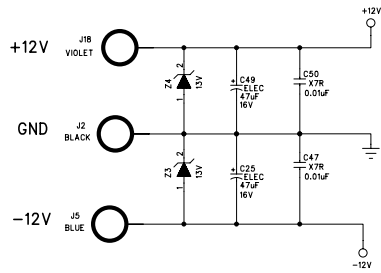
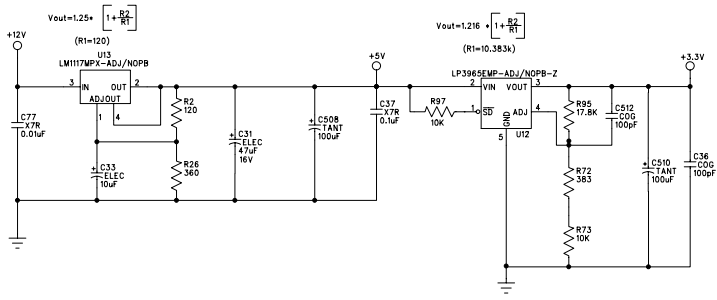

Figure 39. Control Port





Remove Shunt For External Voltage Supply Connection

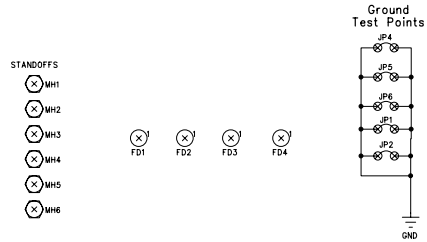
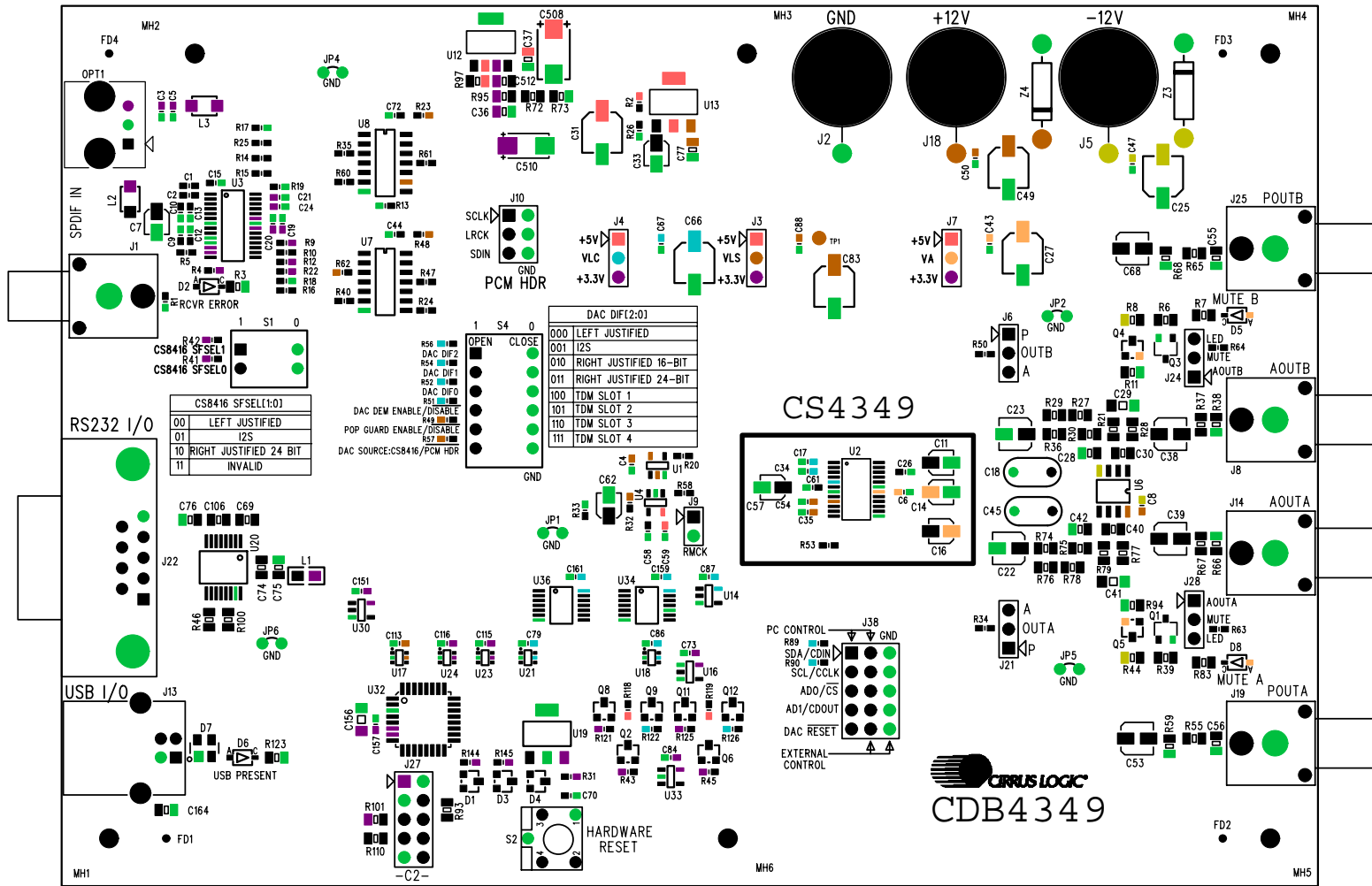

Figure 40. Power



# 12.LAYOUT



CIRrus LOGIC PCB 240-00207-Z1 REV C

Figure 41. Silkscreen Top



CDB4349



CIRRUS LOGIC®

CDB4349

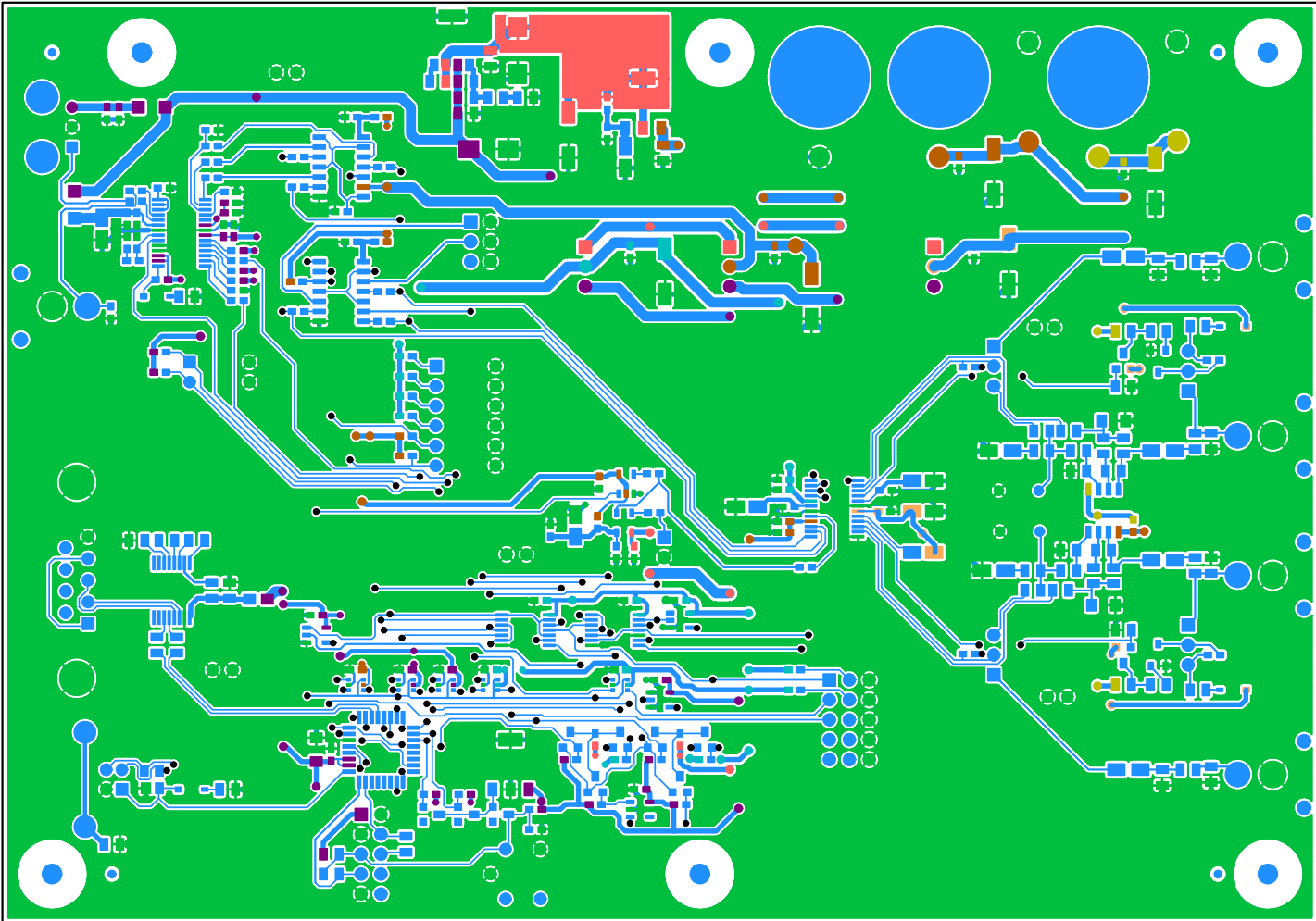

CIRRUS LOGIC PCB 240-00207-Z1 REV C

Figure 42. Top Side



CIRRUS LOGIC®

CDB4349

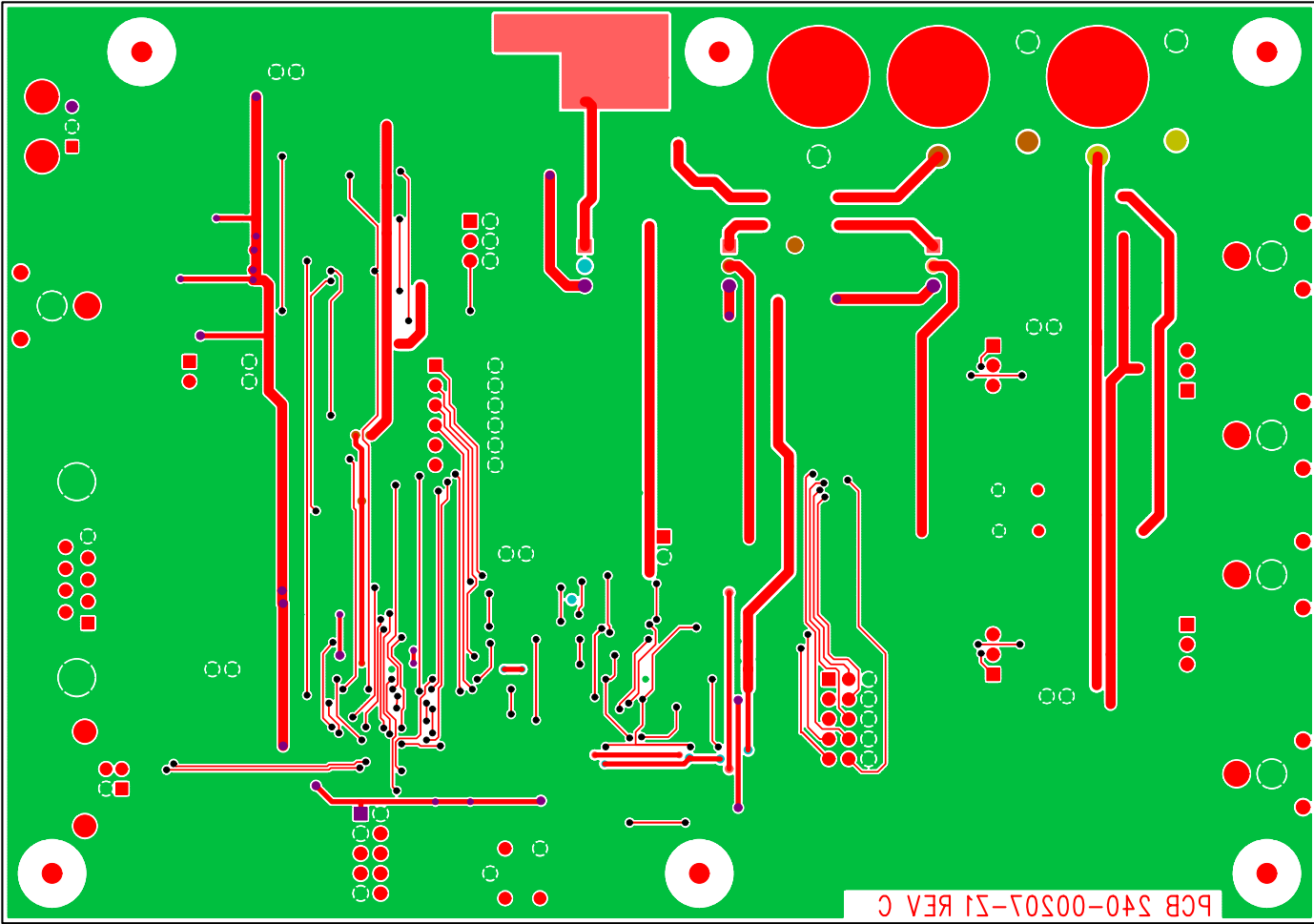

CIRRUS LOGIC PCB 240-00207-Z1 REV C

Figure 43. Bottom Side

---

**13. REVISION HISTORY**

<b>Release</b>	<b>Date</b>	<b>Changes</b>
DB1	June 2007	Initial Evaluation Board Datasheet Release

---

## Contacting Cirrus Logic Support

For all product questions and inquiries, contact a Cirrus Logic Sales Representative.

To find the one nearest to you, go to [www.cirrus.com](http://www.cirrus.com)

---

### IMPORTANT NOTICE

Cirrus Logic, Inc. and its subsidiaries ("Cirrus") believe that the information contained in this document is accurate and reliable. However, the information is subject to change without notice and is provided "AS IS" without warranty of any kind (express or implied). Customers are advised to obtain the latest version of relevant information to verify, before placing orders, that information being relied on is current and complete. All products are sold subject to the terms and conditions of sale supplied at the time of order acknowledgment, including those pertaining to warranty, indemnification, and limitation of liability. No responsibility is assumed by Cirrus for the use of this information, including use of this information as the basis for manufacture or sale of any items, or for infringement of patents or other rights of third parties. This document is the property of Cirrus and by furnishing this information, Cirrus grants no license, express or implied under any patents, mask work rights, copyrights, trademarks, trade secrets or other intellectual property rights. Cirrus owns the copyrights associated with the information contained herein and gives consent for copies to be made of the information only for use within your organization with respect to Cirrus integrated circuits or other products of Cirrus. This consent does not extend to other copying such as copying for general distribution, advertising or promotional purposes, or for creating any work for resale.

CERTAIN APPLICATIONS USING SEMICONDUCTOR PRODUCTS MAY INVOLVE POTENTIAL RISKS OF DEATH, PERSONAL INJURY, OR SEVERE PROPERTY OR ENVIRONMENTAL DAMAGE ("CRITICAL APPLICATIONS"). CIRRUS PRODUCTS ARE NOT DESIGNED, AUTHORIZED OR WARRANTED FOR USE IN PRODUCTS SURGICALLY IMPLANTED INTO THE BODY, AUTOMOTIVE SAFETY OR SECURITY DEVICES, LIFE SUPPORT PRODUCTS OR OTHER CRITICAL APPLICATIONS. INCLUSION OF CIRRUS PRODUCTS IN SUCH APPLICATIONS IS UNDERSTOOD TO BE FULLY AT THE CUSTOMER'S RISK AND CIRRUS DISCLAIMS AND MAKES NO WARRANTY, EXPRESS, STATUTORY OR IMPLIED, INCLUDING THE IMPLIED WARRANTIES OF MERCHANTABILITY AND FITNESS FOR PARTICULAR PURPOSE, WITH REGARD TO ANY CIRRUS PRODUCT THAT IS USED IN SUCH A MANNER. IF THE CUSTOMER OR CUSTOMER'S CUSTOMER USES OR PERMITS THE USE OF CIRRUS PRODUCTS IN CRITICAL APPLICATIONS, CUSTOMER AGREES, BY SUCH USE, TO FULLY INDEMNIFY CIRRUS, ITS OFFICERS, DIRECTORS, EMPLOYEES, DISTRIBUTORS AND OTHER AGENTS FROM ANY AND ALL LIABILITY, INCLUDING ATTORNEYS' FEES AND COSTS, THAT MAY RESULT FROM OR ARISE IN CONNECTION WITH THESE USES.

Cirrus Logic, Cirrus, the Cirrus Logic logo designs, and Popguard are trademarks of Cirrus Logic, Inc. All other brand and product names in this document may be trademarks or service marks of their respective owners.

l<sup>2</sup>C is a registered trademark of Philips Semiconductor.

SPI is a trademark of Motorola, Inc.