

THIS DRAWING AND THE SUBJECT MATTER SHOWN THEREON ARE CONFIDENTIAL AND THE PROPERTY OF BEL/STEWART/TRP CONNECTOR AND SHALL NOT BE REPRODUCED, COPIED, OR USED IN ANY MANNER WITHOUT THE WRITTEN CONSENT OF TRP CONNECTOR.

PRODUCT MAY BE PROTECTED BY ONE OR MORE OF THE FOLLOWING US PATENTS:
 5736910 5939955 6425781 6428361 6554638 6840817 7123117
 7429195 7717749 7808751 6217391 6149050 7924130

REVISIONS				
P	LTN	DESCRIPTION	DATE	OWN APVD
H		LOGO CHANGE	07MAY2013	TY KZ
J		REVISED PER EC-1409035	03NOV2014	TYR TYN

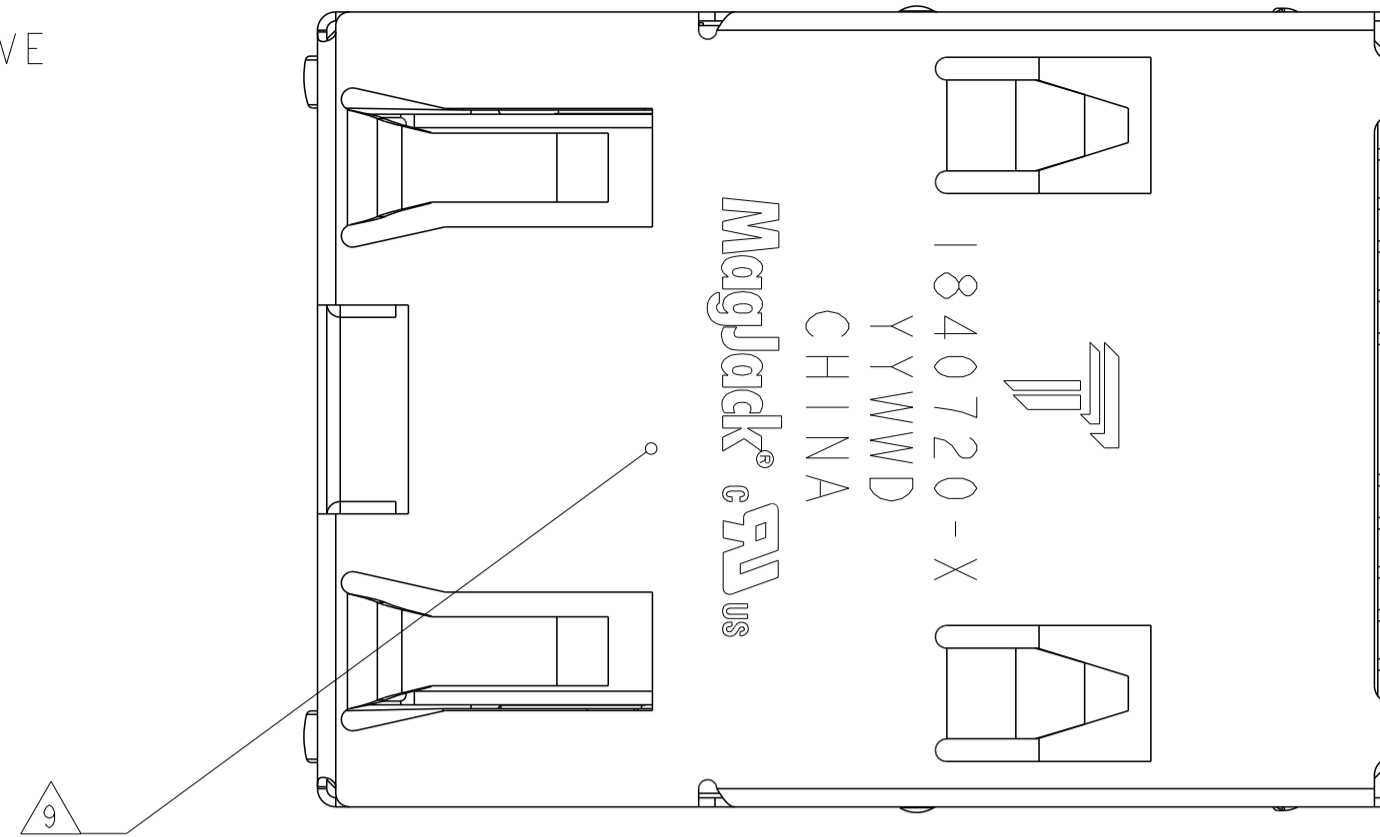
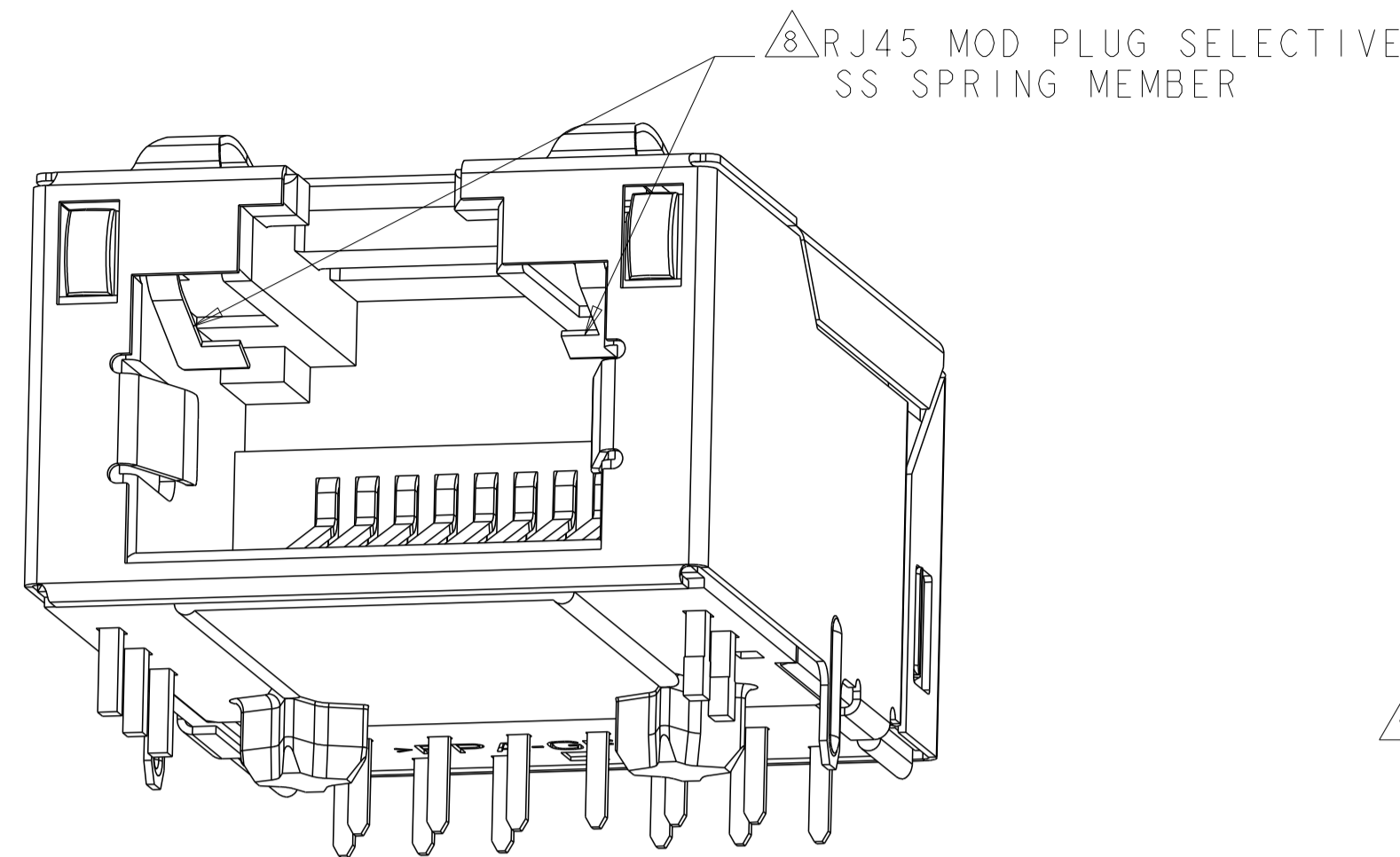

1. MATERIALS:
 -HOUSING: HIGH TEMPERATURE NYLON, BLACK, UL 94V-0
 -SHIELD: 0.20mm THICK, BRASS PREPLATED WITH 0.76 um MIN SEMI-BRIGHT NICKEL; POST-DIPPED WITH 2um MIN LEAD FREE SOLDER
 -CONTACT TAILS: 0.25mm THICK, PHOSPHOR BRONZE, 1.27 um MIN OVERALL NICKEL UNDERPLATE, 3um MIN TIN PLATE
 -MOD JACK CONTACTS: 0.25mm THICK, PHOSPHOR BRONZE, 1.27 um MIN OVERALL NICKEL UNDERPLATE, WITH 0.76um MIN LOCALIZED GOLD PLATE AT PLUG INTERFACE
 -LIGHT EMITTING DIODE (LED): DIFFUSED EPOXY LENS, 0.5mm X 0.5mm CARBON STEEL WIREFRAME LEADS PREPLATED WITH 2.03um MIN. SILVER PLATE OVER 1.02um MIN. NICKEL OVER 1.02um MIN. COPPER UNDERPLATE; LEADS POST-PLATED WITH 3.05um MIN. MATTE TIN. TIP TIN DIPPING
 -LIGHT PIPE: POLYETHER SULFONE

2. RJ45 JACK CAVITY CONFORMS TO FCC RULES AND REGULATIONS PART 68, SUB-PART F.
 3. MAGNETICS:
 -APPLICATION: 10/100 BASE-T
 -IMPEDANCE: 100 OHMS
 -TURNS RATIO (CHIP:CABLE): TX = 1:1, RX = 1:1
 -OPEN CIRCUIT INDUCTANCE (OCL): 350 uH (MIN) @100KHz, 0.1 VRMS WITH 8 mA DC BIAS FROM 0°C TO +70°C, TX AND RX
 -PERFORMANCE @25°C:
 INSERTION LOSS (IL): 1.1dB MAX FROM 0.5MHz TO 100MHz
 RETURN LOSS (RL): 18 dB MIN FROM 0.5MHz TO 30MHz
 18-20log(f/30)dB MIN FROM 30.1MHz TO 60MHz
 12dB MIN FROM 60.1MHz TO 80MHz
 CROSSTALK ATTENUATION: 35dB MIN FROM 0.5MHz TO 40MHz
 33-20log(f/50)dB MIN FROM 40.1MHz TO 100MHz
 COMMON MODE REJECTION RATIO (CMRR): 30dB MIN FROM 0.5MHz TO 100MHz
 -ISOLATION VOLTAGE: COMPLIES WITH IEEE802.3.2002, PARA 23.5.1.1, ITEM a OR b

4. OPERATING TEMPERATURE: FROM 0°C TO +70°C.
 5. LEDs ARE DRIVEN WITH CONSTANT CURRENT AT APPROX 20mA.
 LED COLOR: DOMINANT WAVELENGTH (λD): GREEN 568 nm TYP. at IF=20mA
 FORWARD VOLTAGE (VF): GREEN 2.2V TYP. at IF=20mA
 DOMINANT WAVELENGTH (λD): YELLOW 588 nm TYP. at IF=20mA
 FORWARD VOLTAGE (VF): YELLOW 2.1V TYP. at IF=20mA
 DOMINANT WAVELENGTH (λD): ORANGE 605 nm TYP. at IF=20mA
 FORWARD VOLTAGE (VF): ORANGE 2.1V TYP. at IF=20mA

6. LED WILL EMULATE "YELLOW" LIGHT WHEN BOTH GREEN AND ORANGE DIODES ARE DRIVEN AT CONSTANT CURRENT (20mA RECOMMENDED) TO INDICATE THE THIRD COLOR STATE.

7. ALL DIMENSIONS NOMINAL UNLESS OTHERWISE NOTED.

8. RJ45 MOD PLUG SELECTIVE - THIS CONNECTOR UTILIZES STAINLESS STEEL SPRING MEMBER WHICH PREVENTS THE INSERTION OF A RJ11 (6 POSITION) PLUG INTO THE JACK PORT, WHILE ALLOWING A RJ45 (8 POSITION) PLUG TO MATE FREELY.

- WARNING: THIS FEATURE WAS DEVELOPED FOR TYPICAL PLUG INSERTION FORCES. EXCESSIVE INSERTION FORCE MAY OVERCOME THE SELECTIVE FEATURES AND DAMAGE THE CONNECTOR.

9. TRP CONNECTOR LOGO, PART NUMBER, DATE CODE, PLACE OF ORIGIN, AGENCY LOGO TO BE MARKED IN APPROXIMATE LOCATION AS SHOWN.

10. APPLIES ONLY TO 1840720-2

11. 1840720-1 SHOWN UNLESS OTHERWISE SPECIFIED

12. PART SHOULD BE COMPLIANT WITH BOTH WAVE SOLDERING PROCESS, PREHEAT TEMPERATURE IS 120°C TO 160°C, 120 SECONDS TO 180 SECONDS, PEAK SOLDERING TEMPERATURE 260°C MAX, 10 SECONDS MAX; AND IR REFLOW SOLDERING PROCESS PEAK SOLDERING TEMPERATURE 260°C MAX, DURATION TIME 10 SECONDS MAX, OVER 230°C WITHIN 40-60 SECONDS;

13. THESE PARTS ARE COMPLIANT WITH WAVE SOLDERING PROCESS ONLY, PREHEAT TEMPERATURE IS 120°C TO 160°C, 120 SECONDS TO 180 SECONDS, PEAK SOLDERING TEMPERATURE 260°C MAX, 10 SECONDS MAX;

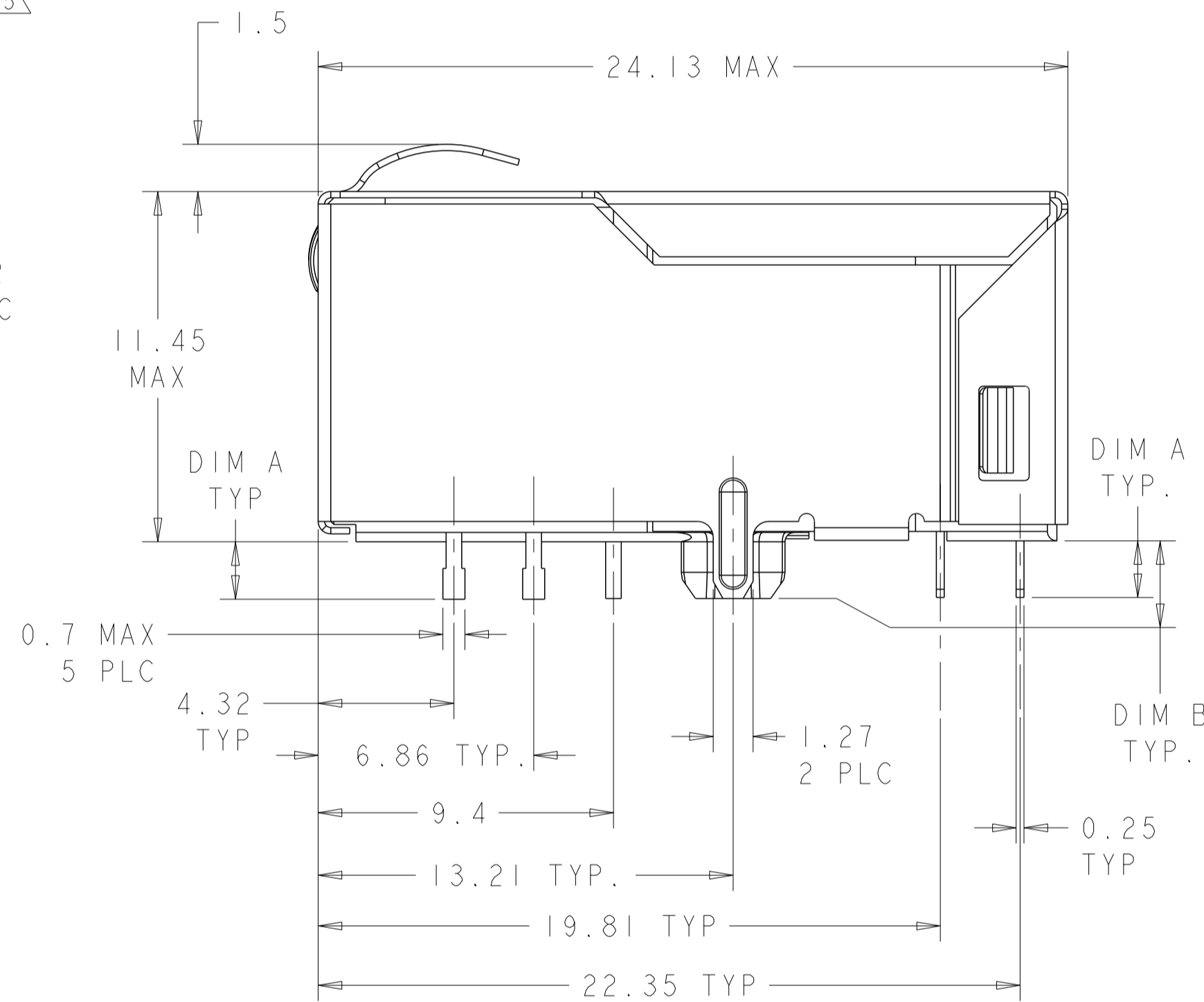
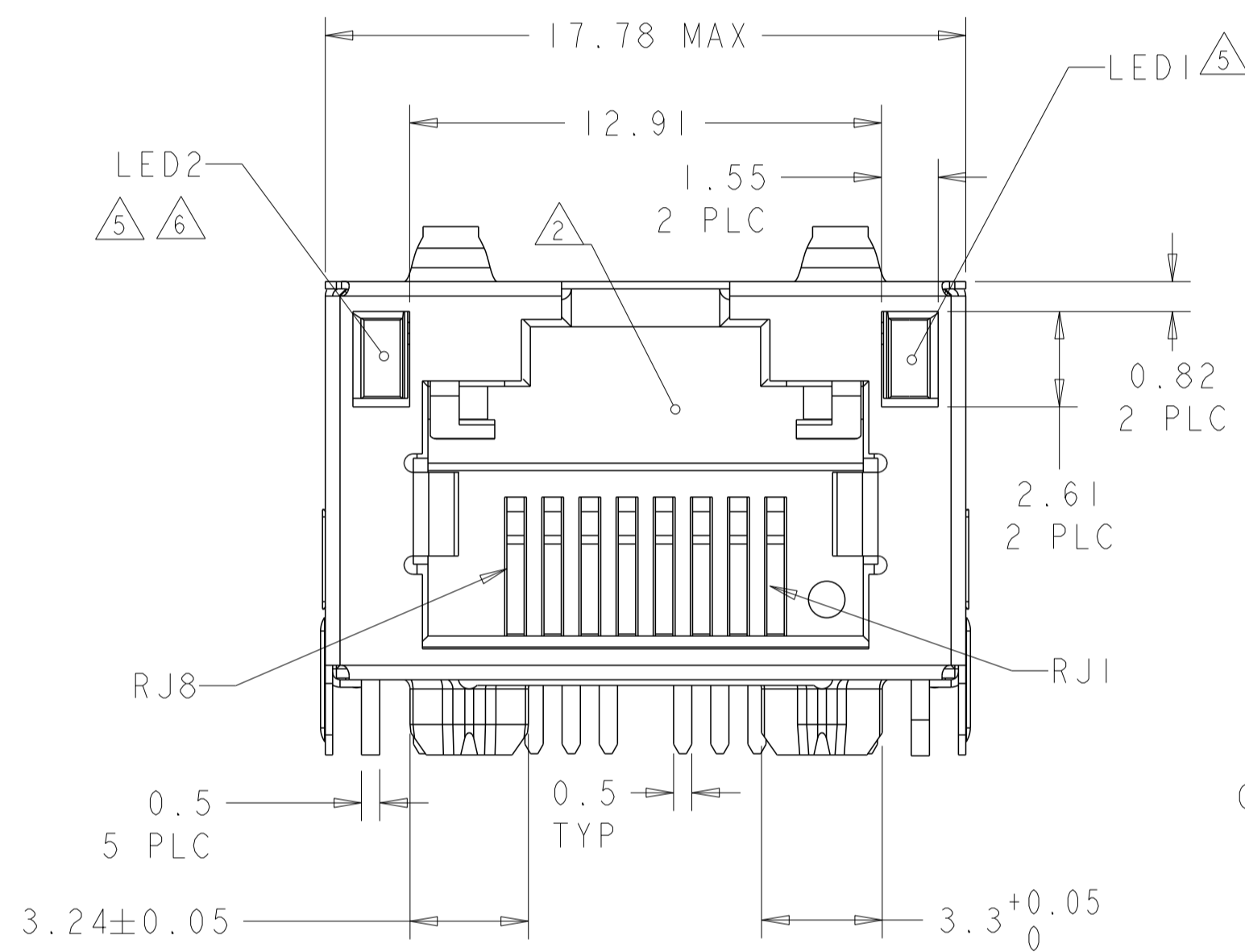

114 10/100 BASE-T CIRCUIT 3 4

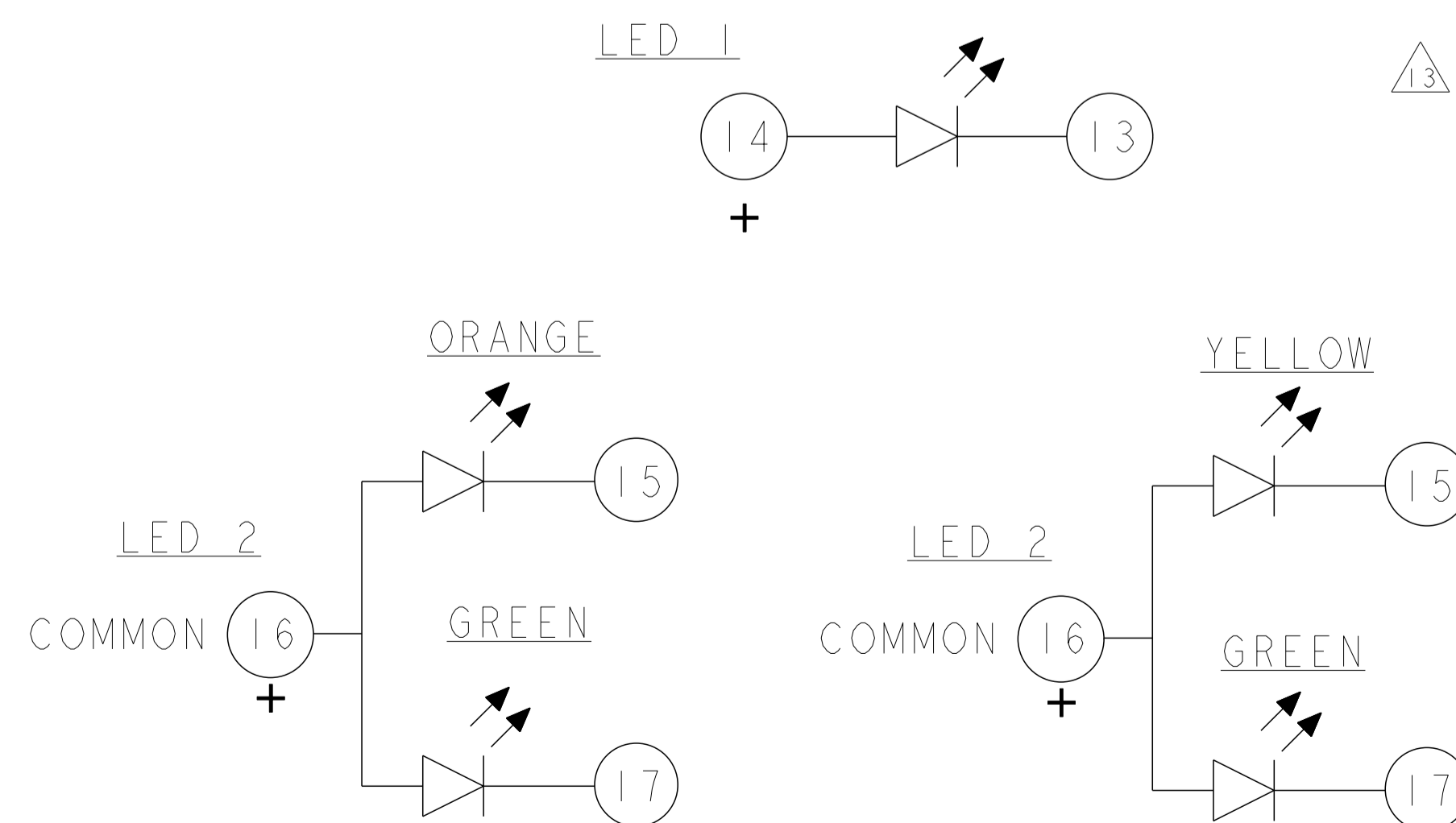
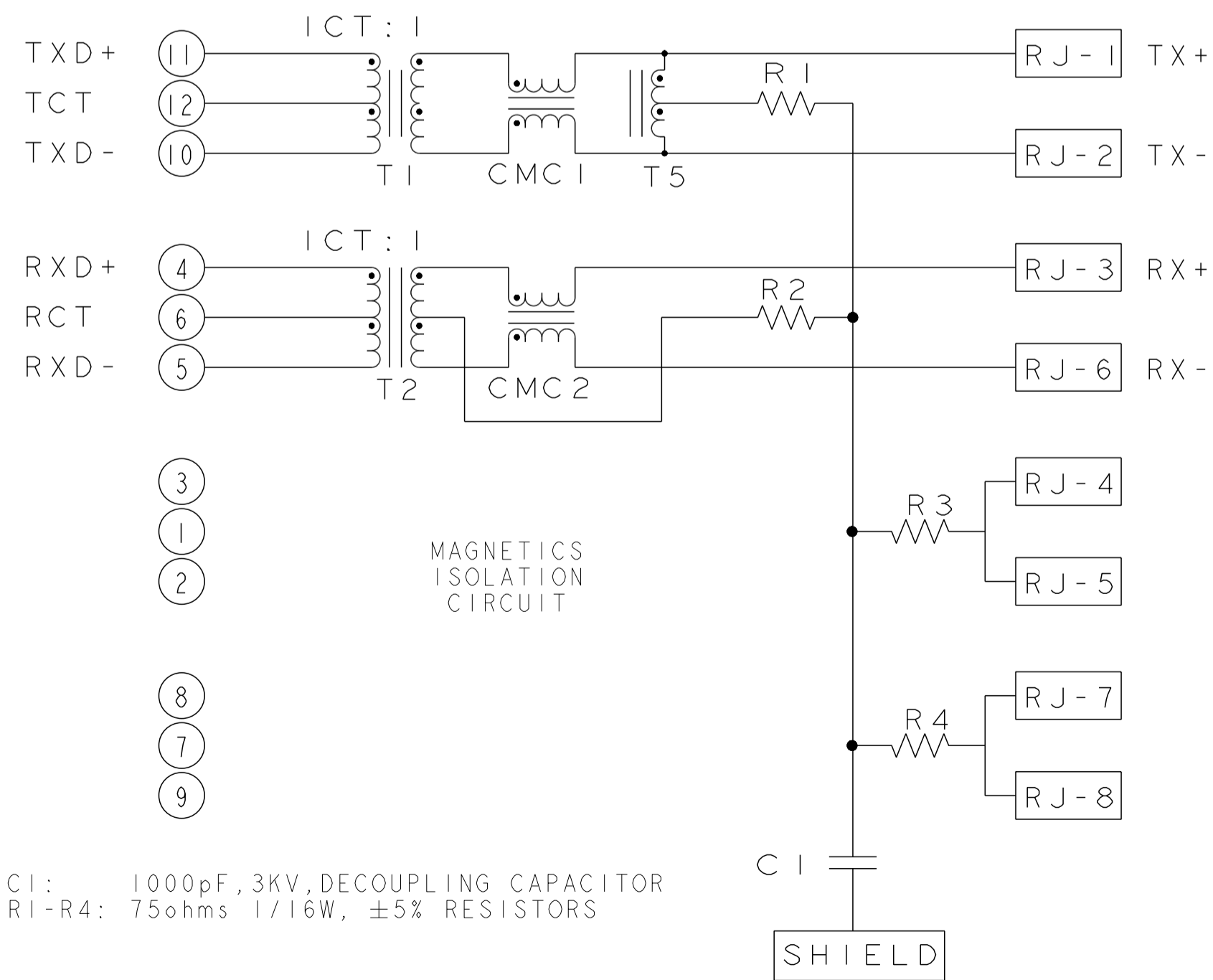

ONLY FOR 1840720-5

TRAY	WAVE	LED 1	LED 2	GROUND TABS	DIM B	DIM A	PART NO.
TRAY	WAVE 13	GREEN	ORANGE/GREEN	TOP ONLY	3.3	3.18	1-1840720-9
TRAY	WAVE 13	GREEN	GREEN/YELLOW	TOP ONLY	3.3	3.18	1840720-5
TRAY	WAVE 13	YELLOW	ORANGE/GREEN	TOP ONLY	3.3	3.18	1840720-3
TAPE AND REEL	BOTH 12	YELLOW	ORANGE/GREEN	TOP AND SIDE	1.8	1.8	1840720-2
TAPE AND REEL	BOTH 12	YELLOW	ORANGE/GREEN	TOP ONLY	1.8	1.8	1840720-1
PACKAGE METHOD	SOLDER PROCESS	LED 1	LED 2	GROUND TABS	DIM B	DIM A	PART NO.

C1: 1000pF, 3KV, DECOUPLING CAPACITOR
 R1-R4: 75ohms 1/16W, ±5% RESISTORS

THIS DRAWING IS A CONTROLLED DOCUMENT.

DIMENSIONS: mm	TOLERANCES UNLESS OTHERWISE SPECIFIED:	OWN: TOWER YU 16MAY2006	CHK: KELTH ZHU 16MAY2006	APVD: TEDDY XIANG 16MAY2006
0 PLC ±0.25	1 PLC ±0.25	2 PLC ±0.25	3 PLC ±	4 PLC ±
ANGLES	APPLICATION SPEC	DONGGUAN CHINA a bel group		
PRODUCT SPEC 108-2207		MODEL NAME: MAGJACK	DESC: 1X1 114 10/100 TAB UP LOW PROFILE W/ LED	RESTRICTED TO
		SINGLE NON-POE	SIZE: A1	SCALE: 4:1 SHEET 1 OF 2 REV J

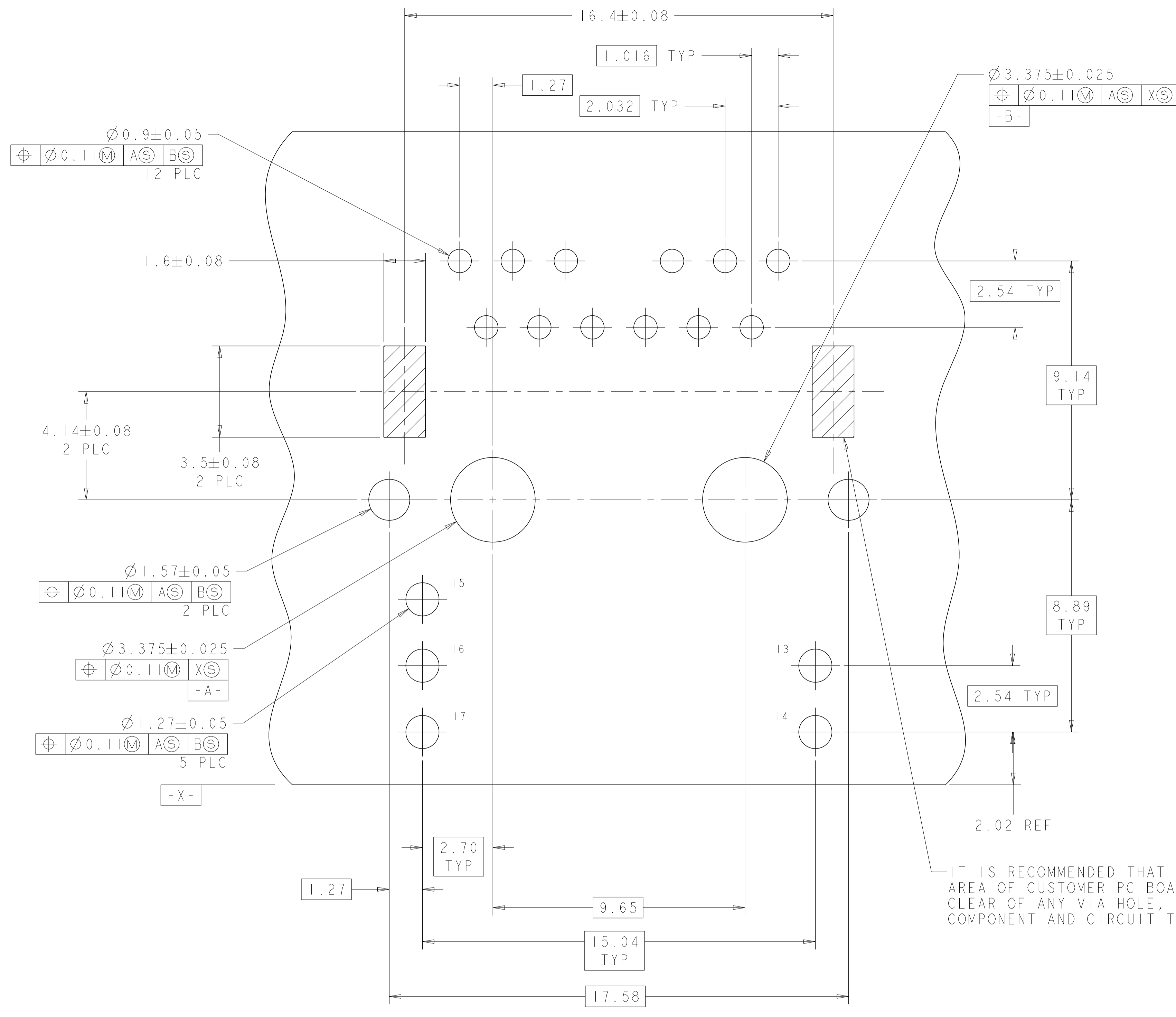

SUGGESTED PCB LAYOUT
(COMPONENT SIDE)

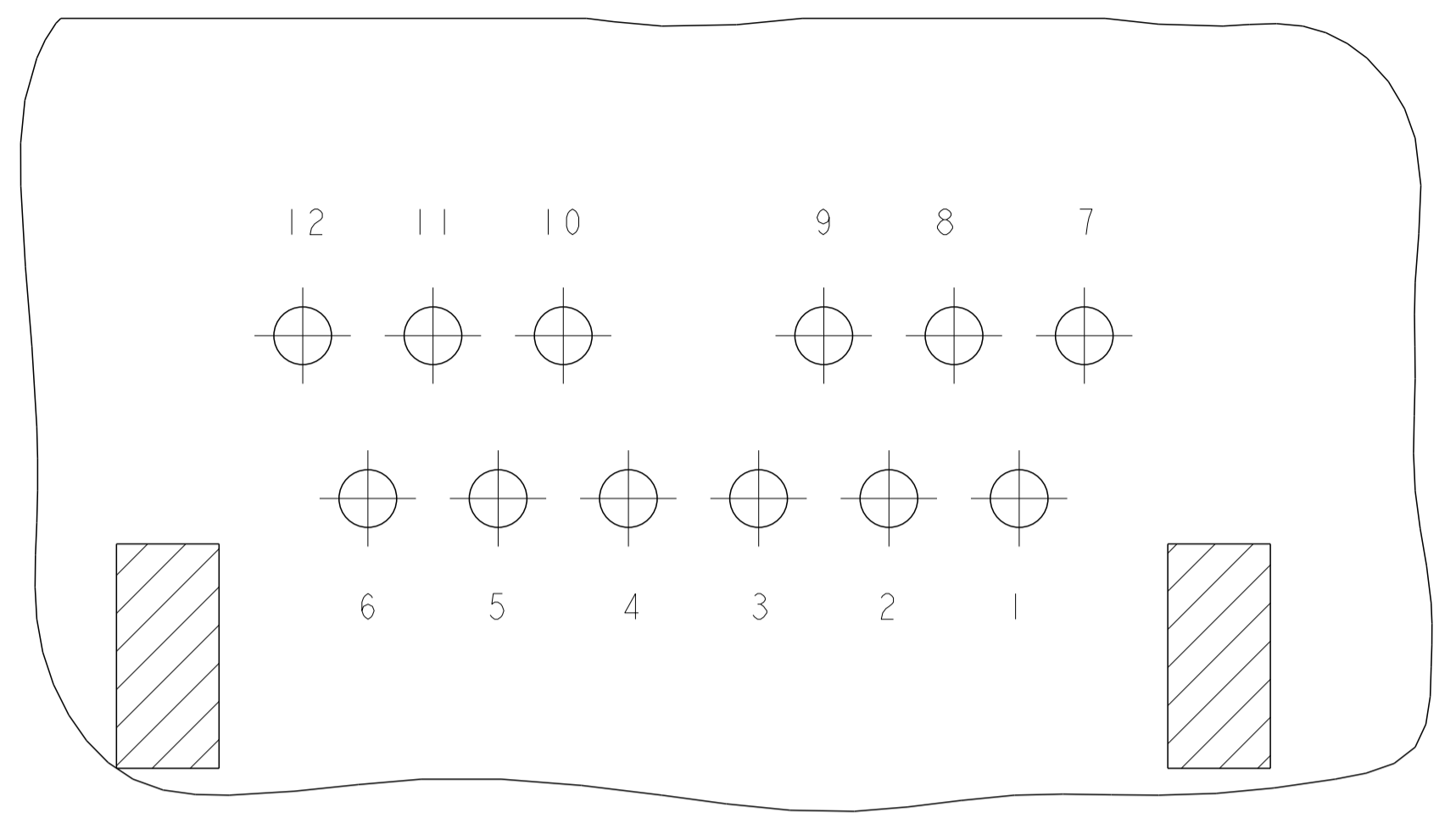

PIN DESIGNATIONS

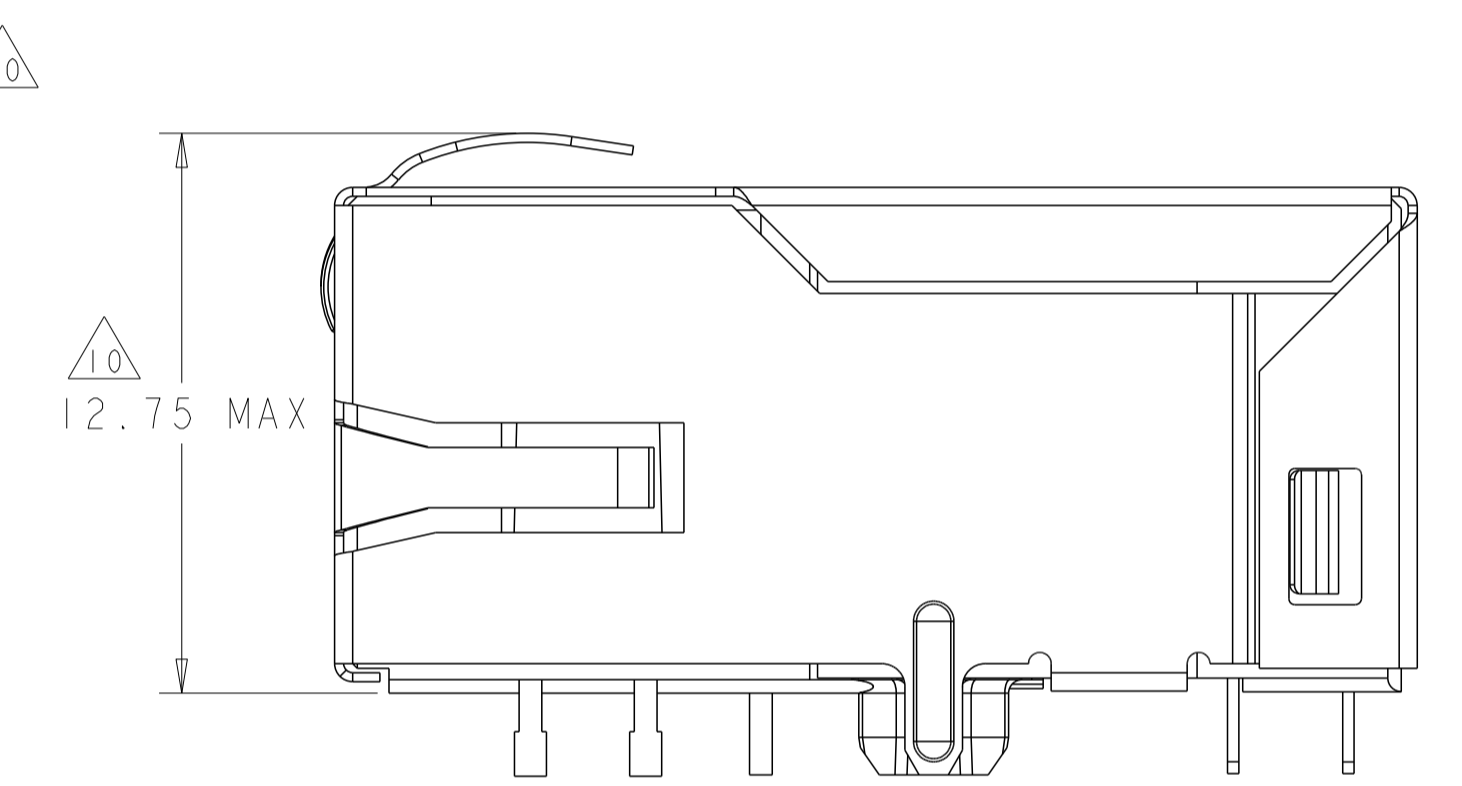
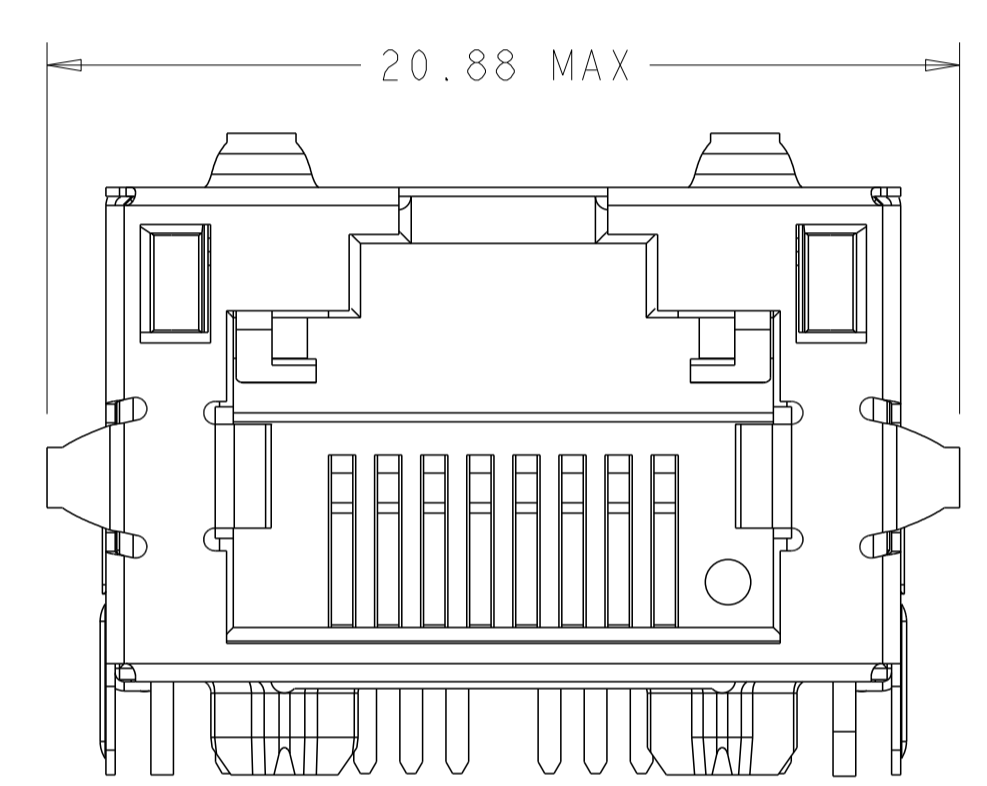

1840720-2

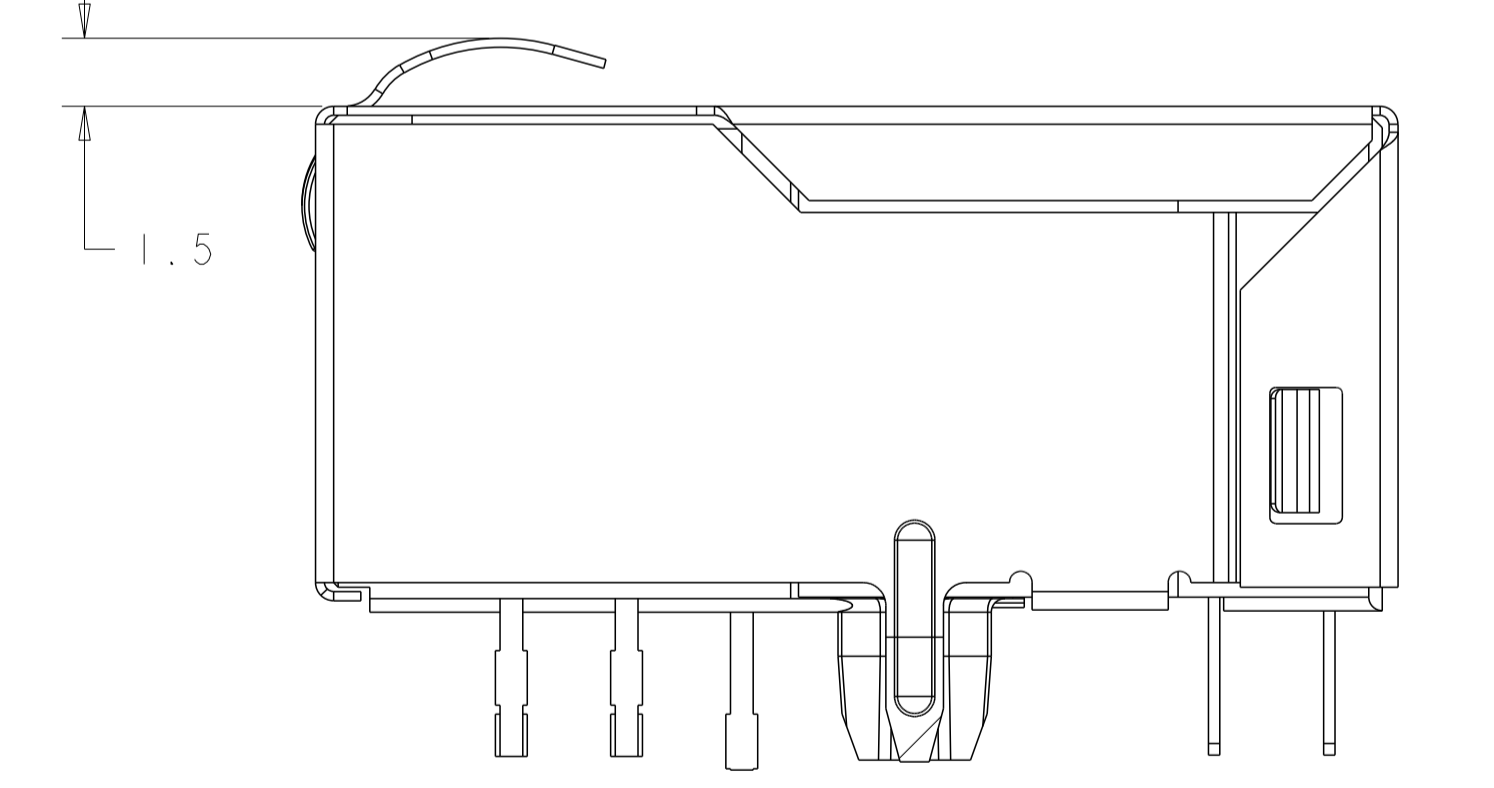
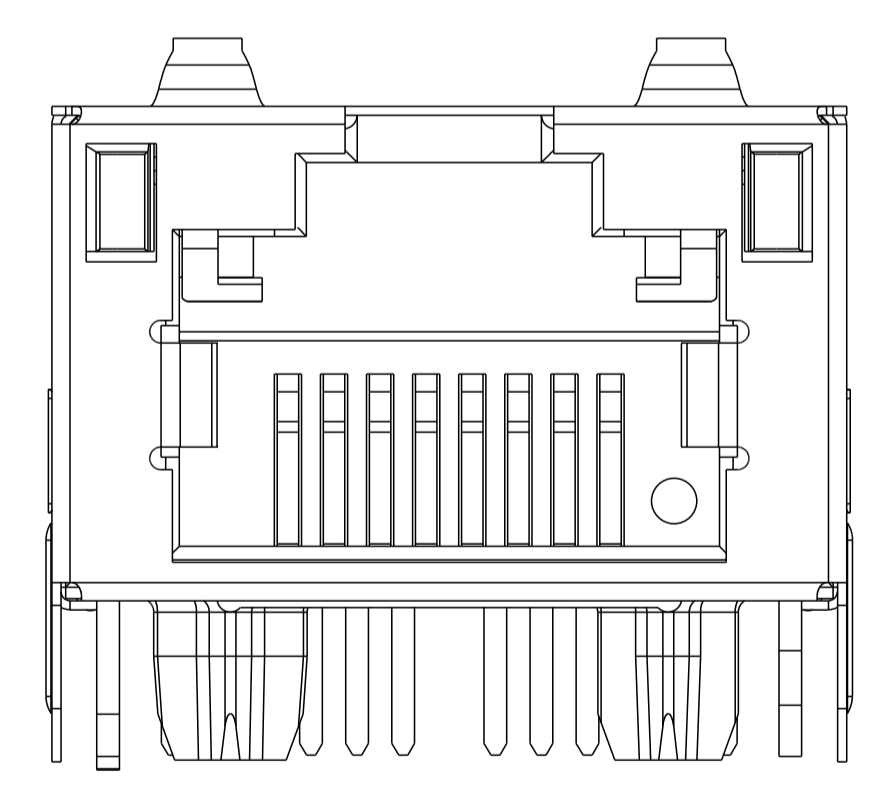

1840720-3
 1840720-5
 1-1840720-9

IT IS RECOMMENDED THAT SHADED AREA OF CUSTOMER PC BOARD BE CLEAR OF ANY VIA HOLE, COMPONENT AND CIRCUIT TRACE

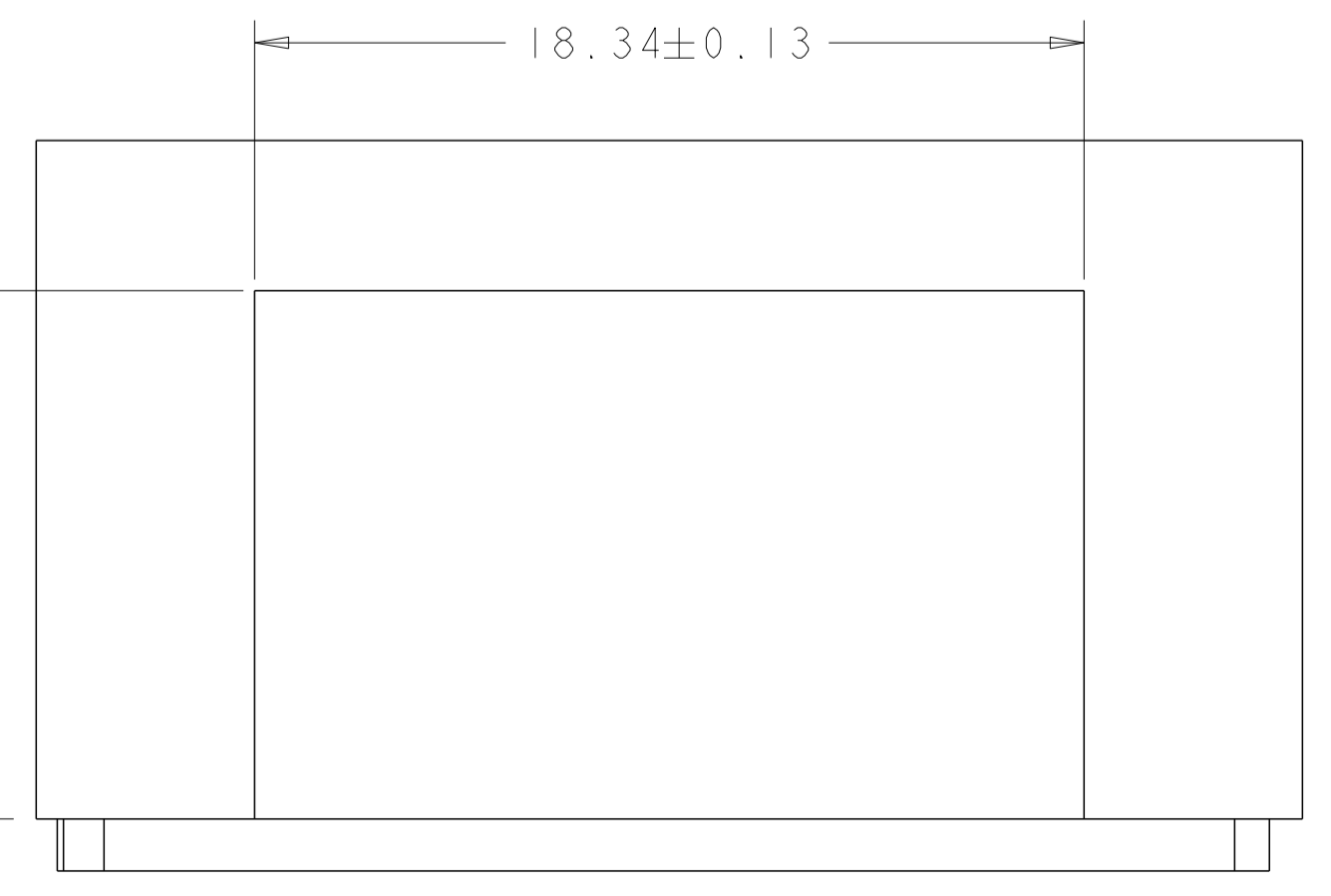

SUGGESTED PANEL OPENING

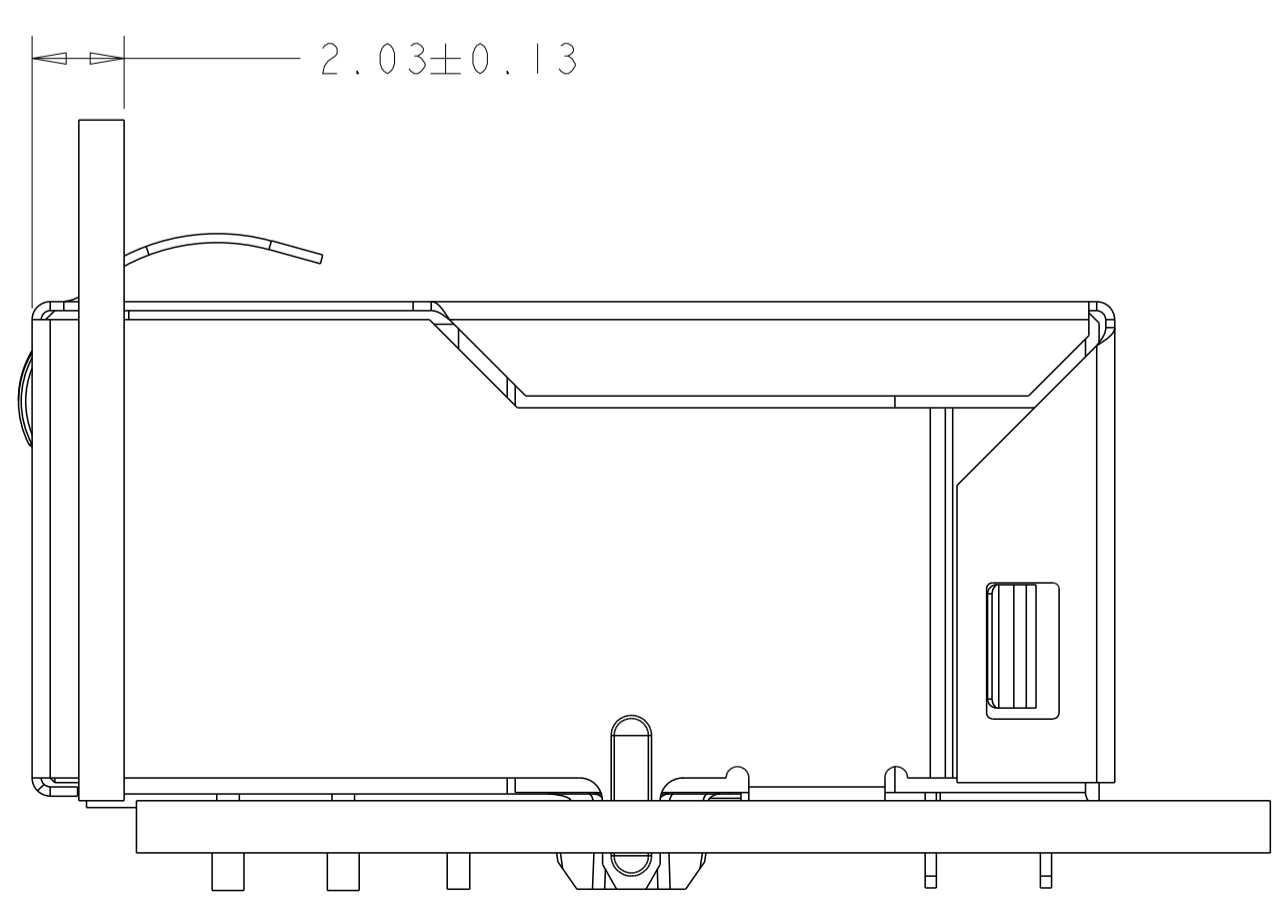

THIS DRAWING IS A CONTROLLED DOCUMENT.		OWN: TOWER YU 16MAY2006	 DONGGUAN CHINA
DIMENSIONS: mm		CHK: KE LTH ZHU 16MAY2006	
TOLERANCES UNLESS OTHERWISE SPECIFIED:		APVD: TEDDY XIONG 16MAY2006	DESC: 1X1 114 10/100 TAB UP LOW PROFILE W/ LED
0 PLC ±0.25 1 PLC ±0.25 2 PLC ±0.25 3 PLC ±0.25 4 PLC ±0.25 ANGLES ±° APPLICATION SPEC ±°	MODEL NAME: MAGJACK PRODUCT SPEC: SINGLE NON-POE 108-2207	SIZE: A1 CAGE CODE: C=1840720 CUSTOMER DRAWING	RESTRICTED TO: - SCALE: 4:1 SHEET: 2 OF 2 REV: J