

1 2 3 4 5 6 7 8

F

F

E

E

D

D

C

C

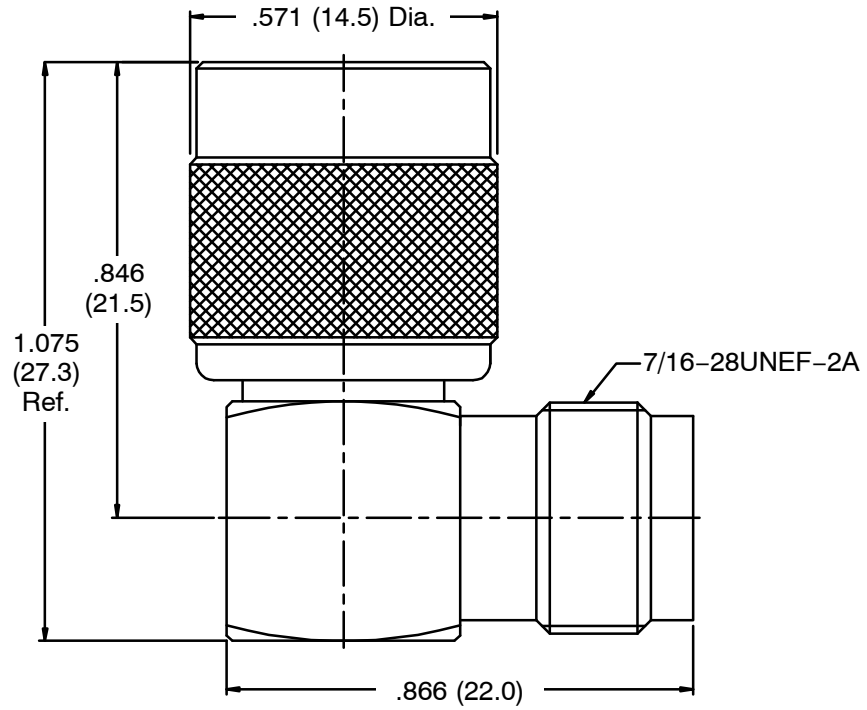

NOTES: Finish (Plating Thickness in Micro-inches)  
 1. Brass  
 2. Nickel Pl. 100 Min. Thick over Copper Pl. 50 Min. Thick  
 3. Phosphor Bronze  
 4. Gold Pl. 3 Min Thick over Nickel Pl. 50 Min. Thick over Copper Pl. 50 Min. Thick  
 5. DELRIN

B

B

A

A

13	Cover	Note 1	Note 2	1	
12	Contact Pin	Note 1	Note 4	1	
11	Washer	Note 1	Note 2	1	
10	Ring	Note 5	Natural	1	
9	Retainer Ring	Note 1	Note 2	1	
8	Gasket	Rubber	Red	1	
7	Insulator	Note 5	Natural	1	
6	Lock Ring	Iron	Note 2	1	
5	Contact Pin	Note 3	Note 4	1	
4	Insulator	Note 5	Natural	1	
3	Body	Note 1	Note 2	1	
2	Housing	Note 1	Note 2	1	
1	Shell	Note 1	Note 2	1	
No	Description	Material	Finish	Q'ty	Drawing No.

RoHS Compliant

Dimensions are in Inches			Part No.		<b>NTE Electronics</b>
Unless Otherwise Specified Tolerances			Approved	Date	
0.5-6 = ±0.2				12-21-2018	
6-30 = ±0.4			Checked	Date	
30-120 = ±0.6				12-21-2018	Title
120-315 = ±1			Drawn	Date	TNC Plug to Jack R/A Adapter
315-1000 = ±1.6				12-21-2018	Drawing No.
1000-2000 = ±2.4					06-T005
Scale	3/1	Issue	A		File No.

1 2 3 4 5 6 7 8