

PART NUMBER	REVISION	DESCRIPTION	FEED TYPE
2836063-1	B	FINE CRIMP HEIGHT ADJUST	MECHANICAL
2836063-2	B	FINE CRIMP HEIGHT ADJUST	PNEUMATIC
7-2836063-1	B	MECHANICAL AND CRIMP TOOLING KIT	MECHANICAL
7-2836063-2	B	PNEUMATIC AND CRIMP TOOLING KIT	PNEUMATIC
7-2836063-7	A	CRIMP TOOLING KIT	-

ATLANTIC VERSION TERMINATOR INTERFACE ADAPTER

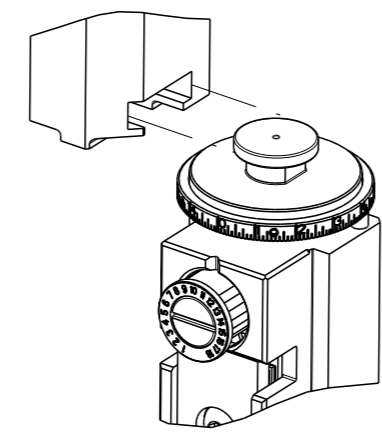

APPLICATOR DATA		
CRIMP	SIZE	TYPE
WIRE	1.88 mm [.074]	F
INSUL	2.11 mm [.083]	F

APPLICATOR INSTRUCTIONS
408-35042

TERMINAL DATA: MOLEX TERMINAL CUSTOMER CRIMP SPECIFICATION			
TERMINAL NAME: TERMINAL - WIRE SNAP ON FEMALE			
WIRE STRIP LENGTH	INSULATION DIAMETER RANGE		
4.59-5.35 mm [.181-.211 IN]	∅ 2.11 mm [.083] MAX		
TERMINAL APPLICATION SPECIFICATION	NONE		
TERMINALS APPLIED			
TE TERMINAL	MOLEX TERMINAL	TE TERMINAL	MOLEX TERMINAL
2208342-2	33113-0003		

WIRE SIZE	CRIMP HEIGHT mm [INCH]	CRIMP HEIGHT REFERENCE SETTING
18 AWG	1.30+/-0.05 [.051+/- .002]	6.5
20 AWG	1.15+/-0.05 [.045+/- .002]	8.4

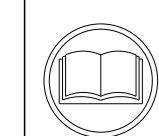

- △ RECOMMENDED SPARE PARTS
 - △ REFER TO SUPPLIED INSTRUCTION SHEET FOR CLEANING, LUBRICATION AND STORAGE OF APPLICATOR.
 - △ APPLY PART NUMBER 2-23419-6 LOCTITE TO THREADS OF ITEM 242.
 - △ CRIMP HEIGHT REFERENCE SETTING WAS THE SETTING USED WHEN THE APPLICATOR WAS QUALIFIED AT THE FACTORY. ADJUSTMENT MAY BE NECESSARY WHEN RUNNING APPLICATOR IN THE FIELD.
 - △ TERMINAL LUBRICANT IS RECOMMENDED.
6. UNLESS SPECIFIED OTHERWISE TORQUE VALUES SHALL BE USED PER DOCUMENT, 101-35000.

***WARNING**
ON INSTALLATION, SET WIRE DISC TO CRIMP HEIGHT REFERENCE SETTING FOR LARGEST WIRE SIZE. CRIMP HEIGHT REFERENCE SETTINGS GREATER THAN THE VALUE SHOWN MAY CAUSE DAMAGE TO THE CRIMP TOOLING, REFER TO THE INSTRUCTION SHEET FOR PROPER SETUP AND ADJUSTMENTS.

ATLANTIC VERSION
Shown on sheets 1 of 4 & 2 of 4
(Pacific version shown on sheets 3 of 4 & 4 of 4)

LOC	DIST	REVISIONS					
		P	LY#	DESCRIPTION	DATE	OWN	APVD
A	66			RELEASED	09DEC2015	LG	TE
				ECR-20-012902 -	11SEP2020	FJ	TE

-	2	2	2	2	2168083-1	SCR, SKT HD CAP, RoHS, M3 X 8.0	269
-	1	1	1	1	1633782-5	FENCE	267
-	1	-	1	-	2119641-1	FEED CAM, AIR FEED	248
-	1	1	1	1	2119082-1	CAM, SNAIL, INSULATION ADJUSTMENT	244
-	1	1	1	1	2079764-1	WASHER, WAVE SPRING, CREST-TO-CREST	243
△	-	1	1	1	2119083-1	RETAINER, INSULATION DIAL	242
-	1	1	1	1	7-18023-7	SCR, SKT HD CAP M3 X 4.0	241
-	-	1	-	1	2119580-1	MECHANICAL FEED ASSEMBLY	239
-	1	-	1	-	2844940-1	AIR FEED MODULE	238
-	REF	REF	REF	REF	994970-2	COUNTER, MAGNETIC	164
△	-	1	1	1	2119955-1	ASSY, LUBRICATOR, SIDE FEED	113
-	1	1	1	1	2844908-1	SCREW, LOCKING	99
-	1	1	1	1	2844907-1	POST, LOCKING	98
-	1	1	1	1	455888-5	SPACER, CRIMPER	82
-	1	1	1	1	1803607-3	DOCUMENTATION PACKAGE	71
-	1	1	1	1	2119791-9	DEPRESSOR, WIRE	70
-	1	1	1	1	2119740-1	TAG, IDENTIFICATION	67
-	2	2	2	2	2168078-1	SCREW, DRIVE, RH, RoHS, 2 x .188	66
-	1	1	1	1	2168083-2	SCR, SKT HD CAP, RoHS, M4 X 8.0	60
-	1	1	1	1	5-18022-5	SCR, HEX HD CAP, M4 X 6.0	59
-	1	1	1	1	1338685-1	PAWL, FEED	56
-	4	4	4	4	2168083-3	SCR, SKT HD CAP, RoHS, M4 X 12.0	54
-	2	2	2	2	2168083-8	SCR, SKT HD CAP, RoHS, M4 X 16	53
-	1	1	1	1	5018030-1	NUT, HEX, REG, RoHS, M3	52
-	1	1	1	1	811242-5	BUMPER, HOLD DOWN	51
-	1	1	1	1	690753-2	SPACER, TONKER	50
-	1	2	1	2	18023-9	SCR, SKT HD CAP M4 X 6.0	49
-	-	1	-	1	2119652-1	FEED CAM, PRE FEED	48
-	-	1	-	1	2119653-1	FEED CAM, POST FEED	47
-	1	1	1	1	1803583-9	APPLICATOR BASIC ASSEMBLY, SF	46
-	1	1	1	1	1803515-1	RAM ASSEMBLY, SF ATLANTIC	44
-	1	1	1	1	1803602-1	SCR, BHSC, RoHS (M8 X 25)	41
-	1	1	1	1	3-1752356-3	SUPPORT, TERMINAL	34
-	2	2	2	2	2079383-5	SCR, BHSC, RoHS (M4 X 20)	33
-	2	2	2	2	2-2844962-6	SPACER, CYLINDRICAL, STRIP GUIDE	30
-	1	1	1	1	2844992-4	ASSEMBLY, STRIP GUIDE	29
-	1	1	1	1	240792-1	DRAG, TERMINAL	25
-	1	1	1	1	1320928-2	STRIP GUIDE	24
-	1	1	1	1	2168083-2	SCR, SKT HD CAP, RoHS, M4 X 8.0	21
-	2	2	2	2	1-18028-2	WASHER, FLAT, REG M4	20
-	1	1	1	1	2119533-1	STRIPPER, SIDE FEED	19
△	-	1	1	1	2119806-1	INSERT, SHEAR	13
-	1	1	1	1	3-22280-3	SPRING, COMPRESSION	12
-	1	1	1	1	1-356885-4	STOP, SHEAR	11
△	-	1	1	1	2119805-1	SHEAR HOLDER, FRONT	10
△	-	1	1	1	454276-5	FLOATING SHEAR, FRONT	9
△	1	2	2	1	1-1803252-4	ANVIL, COMBINATION	8
-	1	1	1	1	240641-5	SPACER	7
-	-	-	-	-	-	-	6
-	1	1	1	1	2119757-4	DEPRESSOR, SHEAR	5
-	1	1	1	1	2-238011-6	BLOCK, CRIMPER SPACER	4
△	1	2	2	1	5-1803187-7	CRIMPER, INSULATION F	3
-	1	1	1	1	455888-3	SPACER, CRIMPER	2
△	1	2	2	1	5-1633305-2	CRIMPER, WIRE PREMIUM	1
-	-77	-72	-71	-2	-1	PART NO	ITEM NO

DIMENSIONS:		TOLERANCES UNLESS OTHERWISE SPECIFIED:		MATERIAL:	
mm	0 PLC ±	1 PLC ±	2 PLC ±	3 PLC ±	4 PLC ±
	ANGLES	FINISH			

OWN	M. RILEY	21OCT2015
CHK	G. BAILEY	12MAR2014
APVD	D. STOUGH	21OCT2015
NAME: Ocean Side Feed Applicator		
SIZE	CAGE CODE	DRAWING NO
A1	00779	2836063
Customer Accessible Production Drawing		
SCALE	1:2	SHEET 1 OF 4
REV	B	

LOC		DIST		REVISIONS			
A	66	P	LYR	DESCRIPTION	DATE	OWN	APVD
		-		SEE SHEET 1			

FEED TYPE MECHANICAL

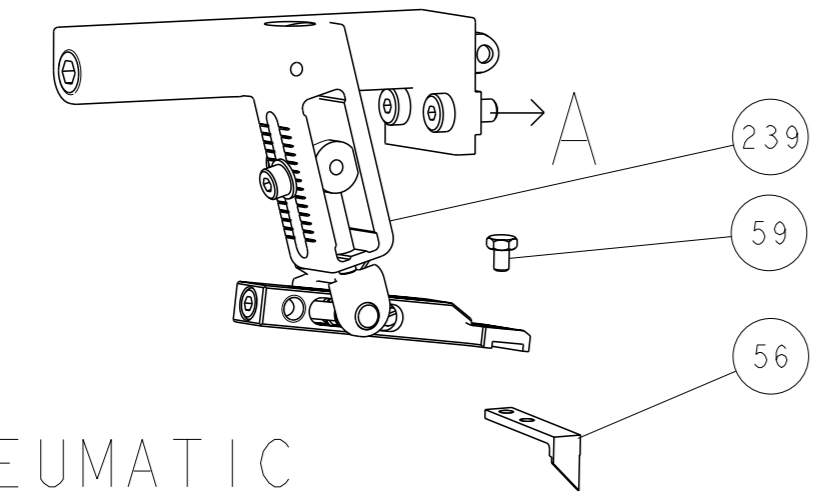

PNEUMATIC

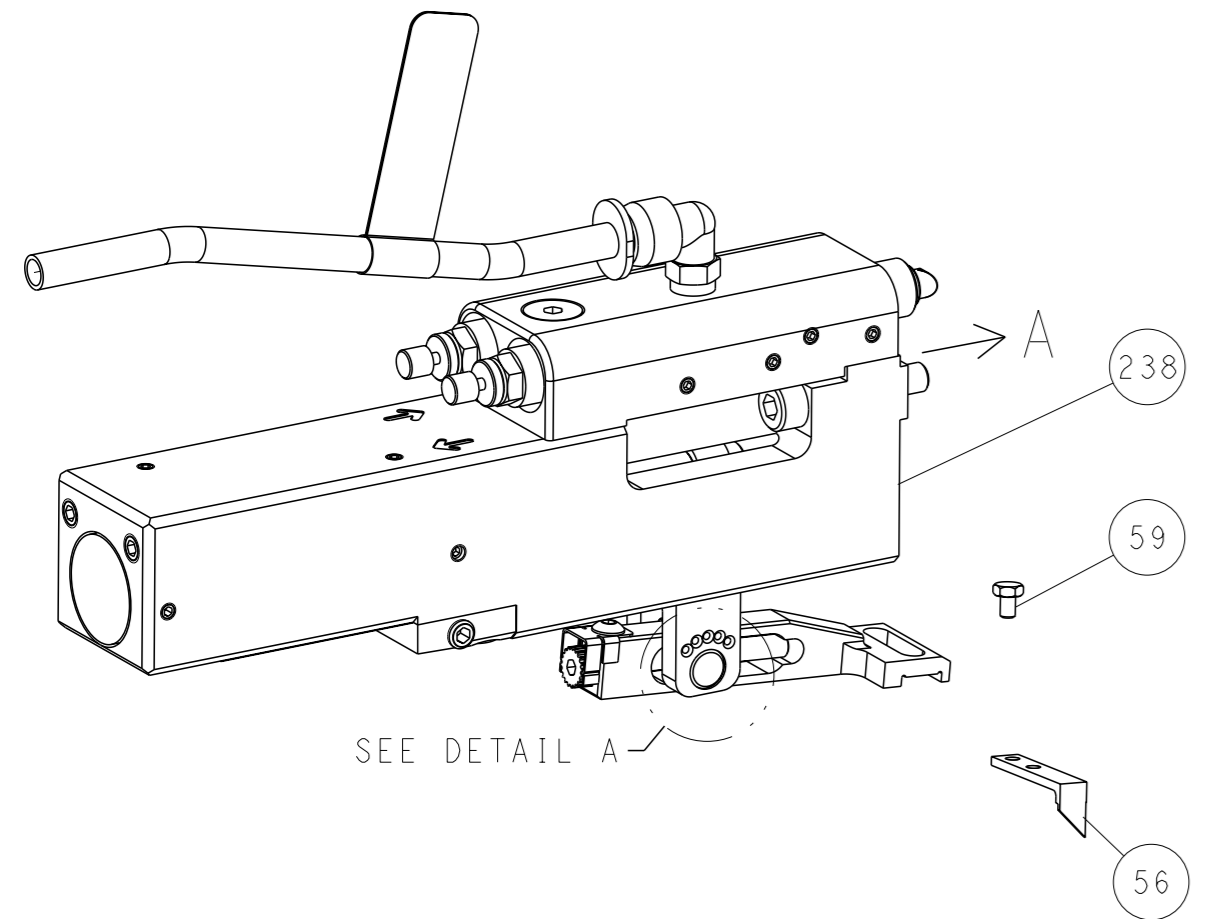

FEED SPRING SETTING POSITION (SHOWN FROM REAR SIDE)

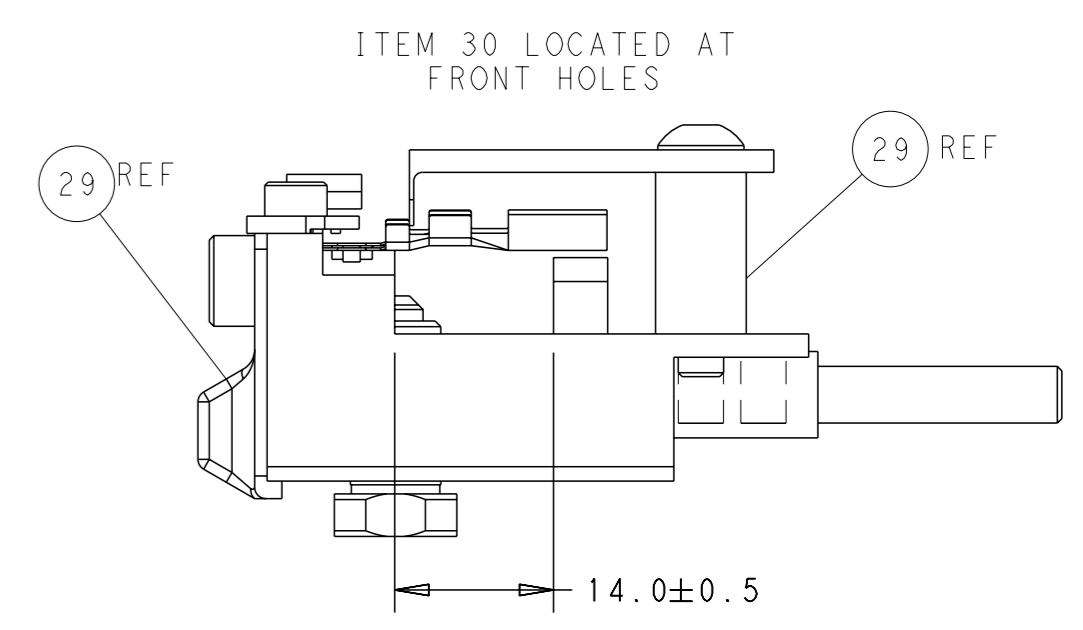
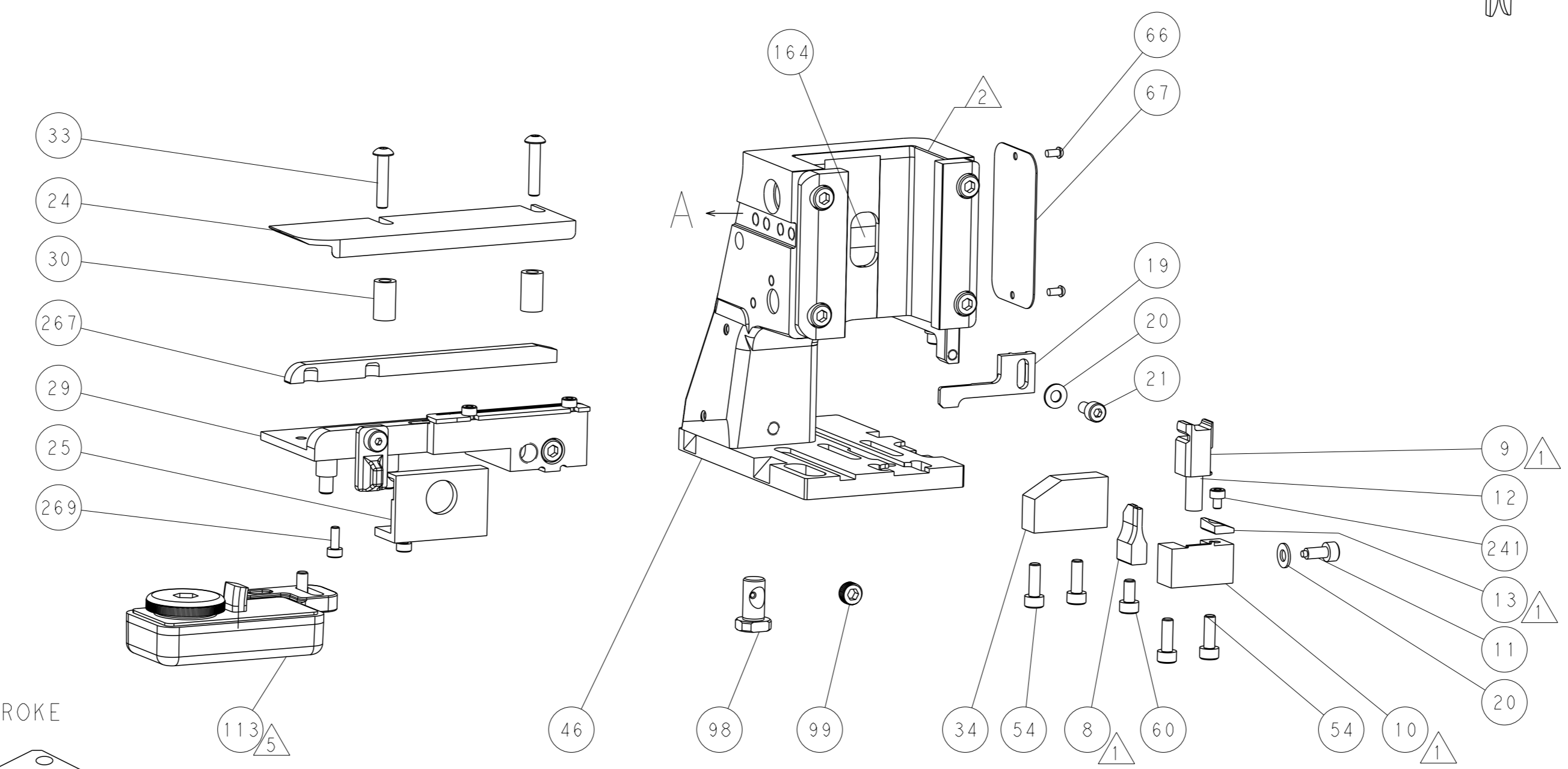
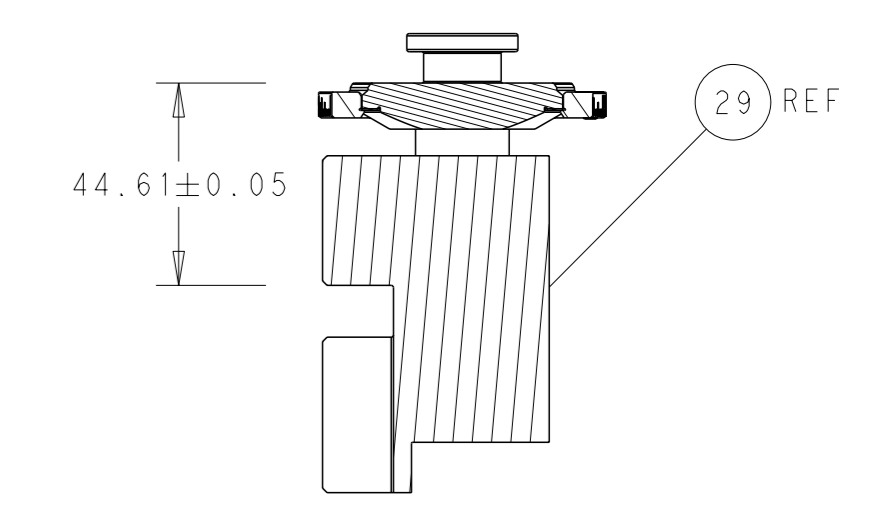
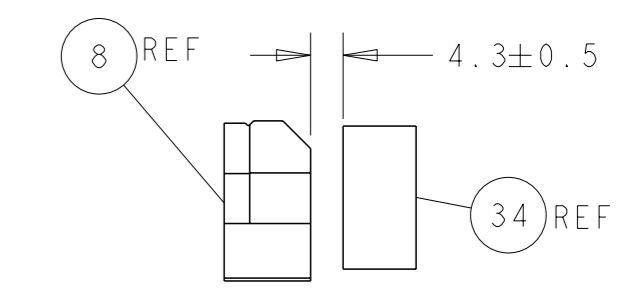
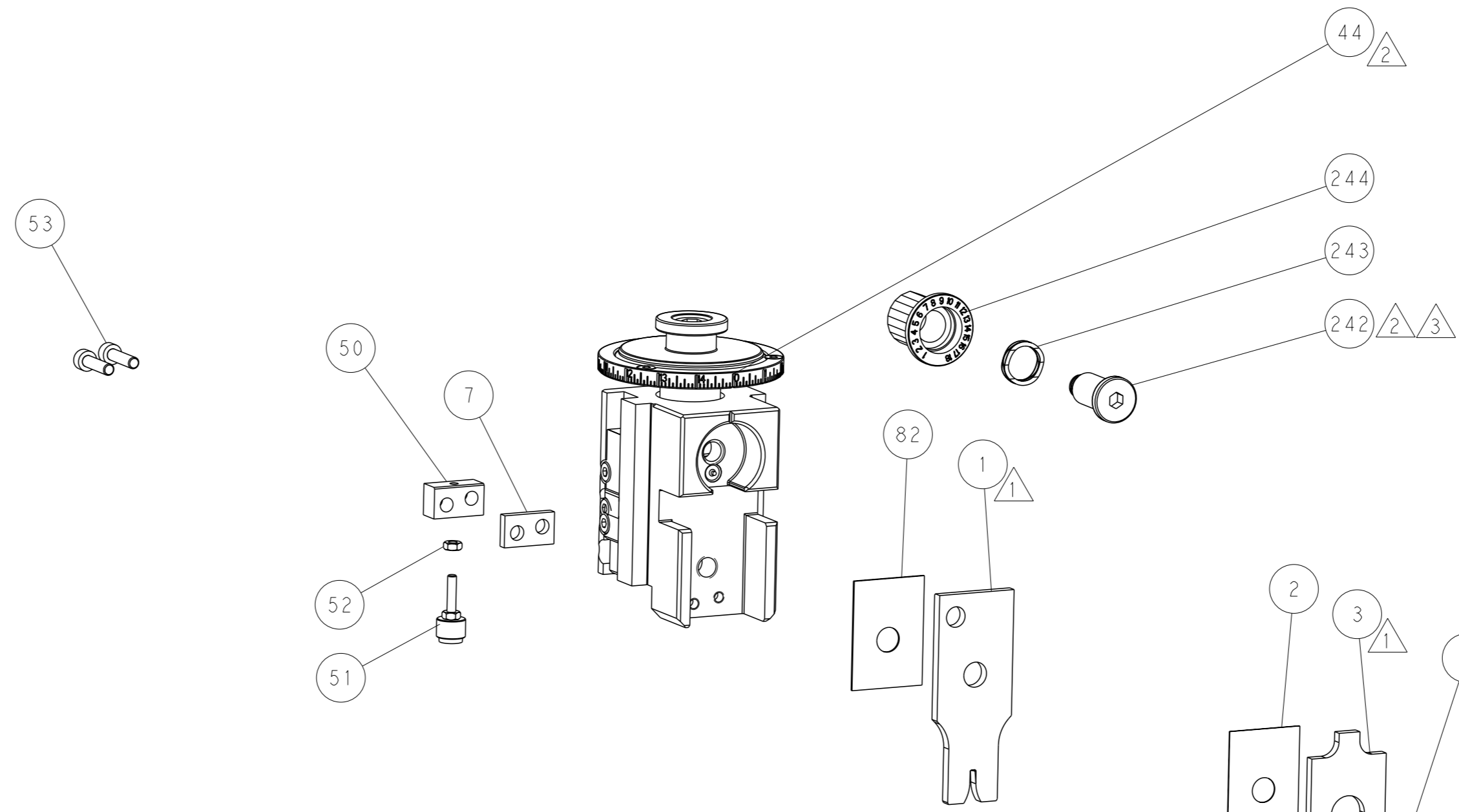
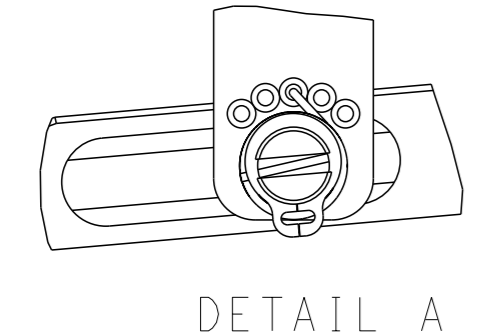

CAM POSITIONS

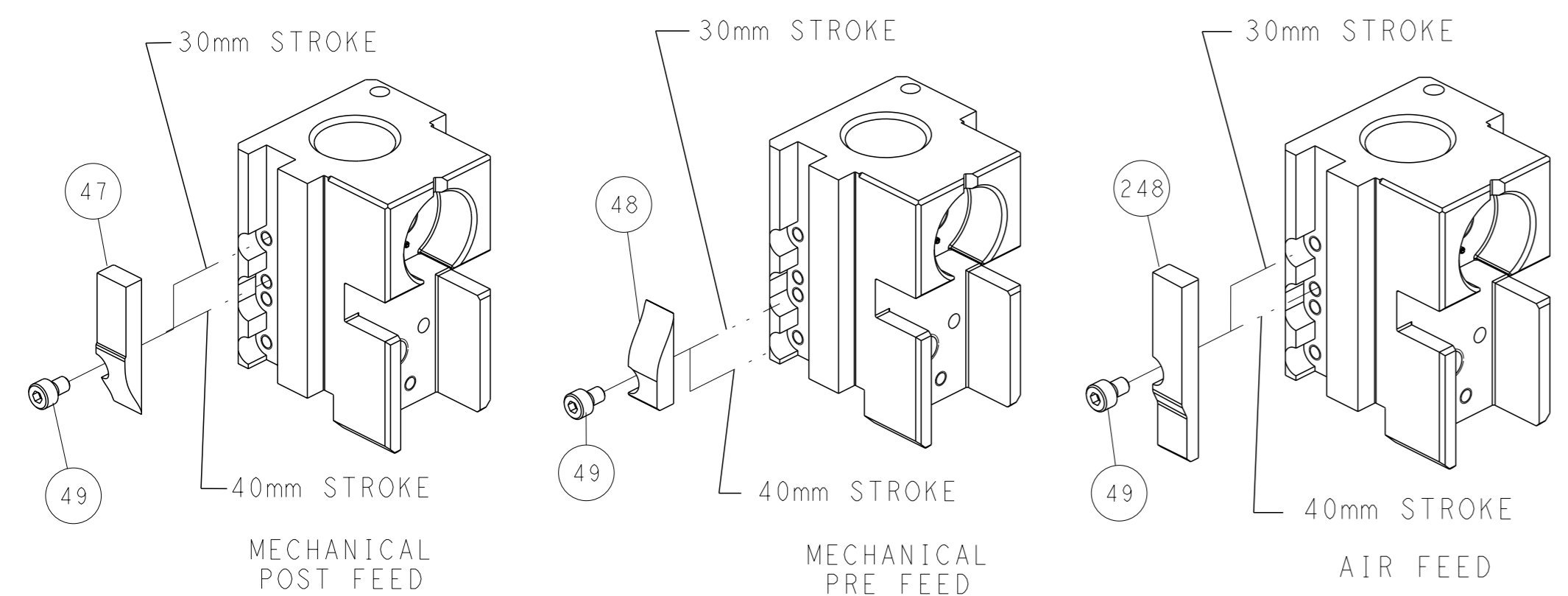

ATLANTIC VERSION
 Shown on sheets 1 of 4 & 2 of 4
 (Pacific version shown on sheets 3 of 4 & 4 of 4)

<small>THIS DRAWING IS UNPUBLISHED. RELEASED FOR PUBLICATION. 20 COPYRIGHT 20 BY TYCO ELECTRONICS CORPORATION. ALL RIGHTS RESERVED.</small>		OWN: M. RILEY 21OCT2015 CHK: G. BAILEY 12MAR2014 APVD: D. STOUGH 21OCT2015 PRODUCT SPEC: - APPLICATION SPEC: - WEIGHT: - MATERIAL: -	NAME: Ocean Side Feed Applicator SIZE: A1 CAGE CODE: 00779 DRAWING NO: 2836063 SCALE: 1:2 SHEET: 2 of 4 REV: B	TE Connectivity Harrisburg, PA 17105-3608
--	--	--	--	--

PART NUMBER	REVISION	DESCRIPTION	FEED TYPE
2-2836063-1	B	FINE CRIMP HEIGHT ADJUST	MECHANICAL
2-2836063-2	B	FINE CRIMP HEIGHT ADJUST	PNEUMATIC
7-2836063-7	A	CRIMP TOOLING KIT	-

PACIFIC VERSION TERMINATOR
INTERFACE ADAPTER

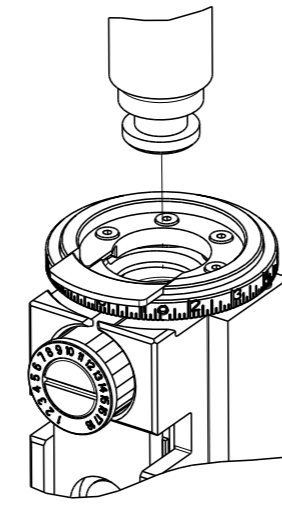

APPLICATOR DATA		
CRIMP	SIZE	TYPE
WIRE	1.88 mm [.074]	F
INSUL	2.11 mm [.083]	F

APPLICATOR INSTRUCTIONS
408-35042

TERMINAL DATA: MOLEX TERMINAL CUSTOMER CRIMP SPECIFICATION			
TERMINAL NAME: TERMINAL - WIRE SNAP ON FEMALE			
WIRE STRIP LENGTH		INSULATION DIAMETER RANGE	
4.59-5.35 mm [.181-.211 IN]		∅ 2.11 mm [.083] MAX	
TERMINAL APPLICATION SPECIFICATION	NONE		
TERMINALS APPLIED			
TE TERMINAL	MOLEX TERMINAL	TE TERMINAL	MOLEX TERMINAL
2208342-2	33113-0003		

WIRE SIZE	CRIMP HEIGHT mm [INCH]	CRIMP HEIGHT REFERENCE SETTING
18 AWG	1.30+/-0.05 [.051+/-0.002]	6.5
20 AWG	1.15+/-0.05 [.045+/-0.002]	8.4



- △ RECOMMENDED SPARE PARTS
 - △ REFER TO SUPPLIED INSTRUCTION SHEET FOR CLEANING, LUBRICATION AND STORAGE OF APPLICATOR.
 - △ APPLY PART NUMBER 2-23419-6 LOCTITE TO THREADS OF ITEM 242.
 - △ CRIMP HEIGHT REFERENCE SETTING WAS THE SETTING USED WHEN THE APPLICATOR WAS QUALIFIED AT THE FACTORY. ADJUSTMENT MAY BE NECESSARY WHEN RUNNING APPLICATOR IN THE FIELD.
 - △ TERMINAL LUBRICANT IS RECOMMENDED.
6. UNLESS SPECIFIED OTHERWISE TORQUE VALUES SHALL BE USED PER DOCUMENT, 101-35000.

***WARNING**
ON INSTALLATION, SET WIRE DISC TO CRIMP HEIGHT REFERENCE SETTING FOR LARGEST WIRE SIZE. CRIMP HEIGHT REFERENCE SETTINGS GREATER THAN THE VALUE SHOWN MAY CAUSE DAMAGE TO THE CRIMP TOOLING, REFER TO THE INSTRUCTION SHEET FOR PROPER SETUP AND ADJUSTMENTS.

PACIFIC VERSION
Shown on sheets 3 of 4 & 4 of 4
(Atlantic version shown on sheets 1 of 4 & 2 of 4)

LOC	DIST	REVISIONS					
A	66	P	LYR	DESCRIPTION	DATE	OWN	APVD
		-		SEE SHEET 1			

-	2	2	2168083-1	SCR, SKT HD CAP, RoHS, M3 X 8.0	269
-	1	1	1633782-5	FENCE	267
-	1	1	2119082-1	CAM, SNAIL, INSULATION ADJUSTMENT	244
-	1	1	2079764-1	WASHER, WAVE SPRING, CREST-TO-CREST	243
-	1	1	2119083-1	RETAINER, INSULATION DIAL	242
-	1	1	7-18023-7	SCR, SKT HD CAP M3 X 4.0	241
-	-	1	2119580-1	MECHANICAL FEED ASSEMBLY	239
-	1	-	2844940-1	AIR FEED MODULE	238
-	REF	REF	994970-2	COUNTER, MAGNETIC	164
-	1	-	2119641-2	FEED CAM, AIR FEED	151
-	1	1	2168083-8	SCR, SKT HD CAP, RoHS, M4 X 16	144
-	4	4	2168083-9	SCR, SKT HD CAP, RoHS, M4 X 20	143
-	-	1	2119653-2	FEED CAM, POST FEED	142
-	1	1	1-1803583-0	APPLICATOR BASIC ASSEMBLY, SF	141
-	1	1	1803516-1	RAM ASSEMBLY, SF PACIFIC	140
-	1	1	2119955-1	ASSY, LUBRICATOR, SIDE FEED	113
-	1	1	2844908-1	SCREW, LOCKING	99
-	1	1	2844907-1	POST, LOCKING	98
-	1	1	455888-5	SPACER, CRIMPER	82
-	1	1	1803607-3	DOCUMENTATION PACKAGE	71
-	1	1	2119791-9	DEPRESSOR, WIRE	70
-	1	1	2119740-1	TAG, IDENTIFICATION	67
-	2	2	2168078-1	SCREW, DRIVE, RH, RoHS, 2 x .188	66
-	1	1	5-18022-5	SCR, HEX HD CAP, M4 X 6.0	59
-	1	1	1338685-1	PAWL, FEED	56
-	2	2	2168083-8	SCR, SKT HD CAP, RoHS, M4 X 16	53
-	1	1	5018030-1	NUT, HEX, REG, RoHS, M3	52
-	1	1	811242-5	BUMPER, HOLD DOWN	51
-	1	1	690753-2	SPACER, TONKER	50
-	1	2	18023-9	SCR, SKT HD CAP M4 X 6.0	49
-	-	1	2119652-1	FEED CAM, PRE FEED	48
-	1	1	1803602-1	SCR, BHSC, RoHS (M8 X 25)	41
-	1	1	3-1752356-3	SUPPORT, TERMINAL	34
-	2	2	2079383-5	SCR, BHSC, RoHS (M4 X 20)	33
-	2	2	2-2844962-6	SPACER, CYLINDRICAL, STRIP GUIDE	30
-	1	1	2844992-4	ASSEMBLY, STRIP GUIDE	29
-	1	1	240792-1	DRAG, TERMINAL	25
-	1	1	1320928-2	STRIP GUIDE	24
-	1	1	2168083-2	SCR, SKT HD CAP, RoHS, M4 X 8.0	21
-	2	2	1-18028-2	WASHER, FLAT, REG M4	20
-	1	1	2119533-1	STRIPPER, SIDE FEED	19
-	1	1	2119806-1	INSERT, SHEAR	13
-	1	1	3-22280-3	SPRING, COMPRESSION	12
-	1	1	1-356885-4	STOP, SHEAR	11
-	1	1	2119805-1	SHEAR HOLDER, FRONT	10
-	1	1	454276-5	FLOATING SHEAR, FRONT	9
-	1	1	1-1803252-4	ANVIL, COMBINATION	8
-	1	1	240641-5	SPACER	7
-	-	-	-	-	6
-	1	1	2119757-4	DEPRESSOR, SHEAR	5
-	1	1	2-238011-6	BLOCK, CRIMPER SPACER	4
-	1	1	5-1803187-7	CRIMPER, INSULATION F	3
-	1	1	455888-3	SPACER, CRIMPER	2
-	1	1	5-1633305-2	CRIMPER, WIRE PREMIUM	1
-	77	-22	-21	PART NO	ITEM NO

<small>THE DRAWING IS CONTROLLED DOCUMENT FROM THE ELECTRONIC CORPORATION IT IS SUBJECT TO CHANGE AND THE USER MUST CONTACT THE DRAWING ENGINEER WHEN CONTACTED FOR THE LATEST REVISION.</small>		OWN: M. RILEY 21OCT2015 CHK: G. BAILEY 12MAR2014 APVD: D. STOUGH 21OCT2015 PRODUCT SPEC: - APPLICATION SPEC: - MATERIAL: - FINISH: -	NAME: Ocean Side Feed Applicator SIZE: A1 CAGE CODE: 00779 DRAWING NO: 2836063 SCALE: 1:2 SHEET: 3 of 4 REV: B
DIMENSIONS: mm 0 PLC ± 1 PLC ± 2 PLC ± 3 PLC ± 4 PLC ± ANGLES ± FINISH ±		TOLERANCES UNLESS OTHERWISE SPECIFIED: ± ± ± ± ± ±	RESTRICTED TO: - Customer Accessible Production Drawing

LOC		DIST		REVISIONS			
A	66	P	LYR	DESCRIPTION	DATE	OWN	APVD
		-		SEE SHEET 1			

FEED TYPE MECHANICAL

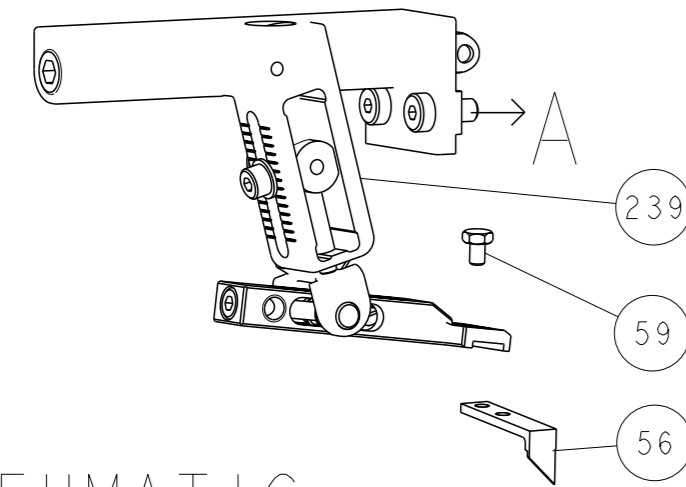

PNEUMATIC

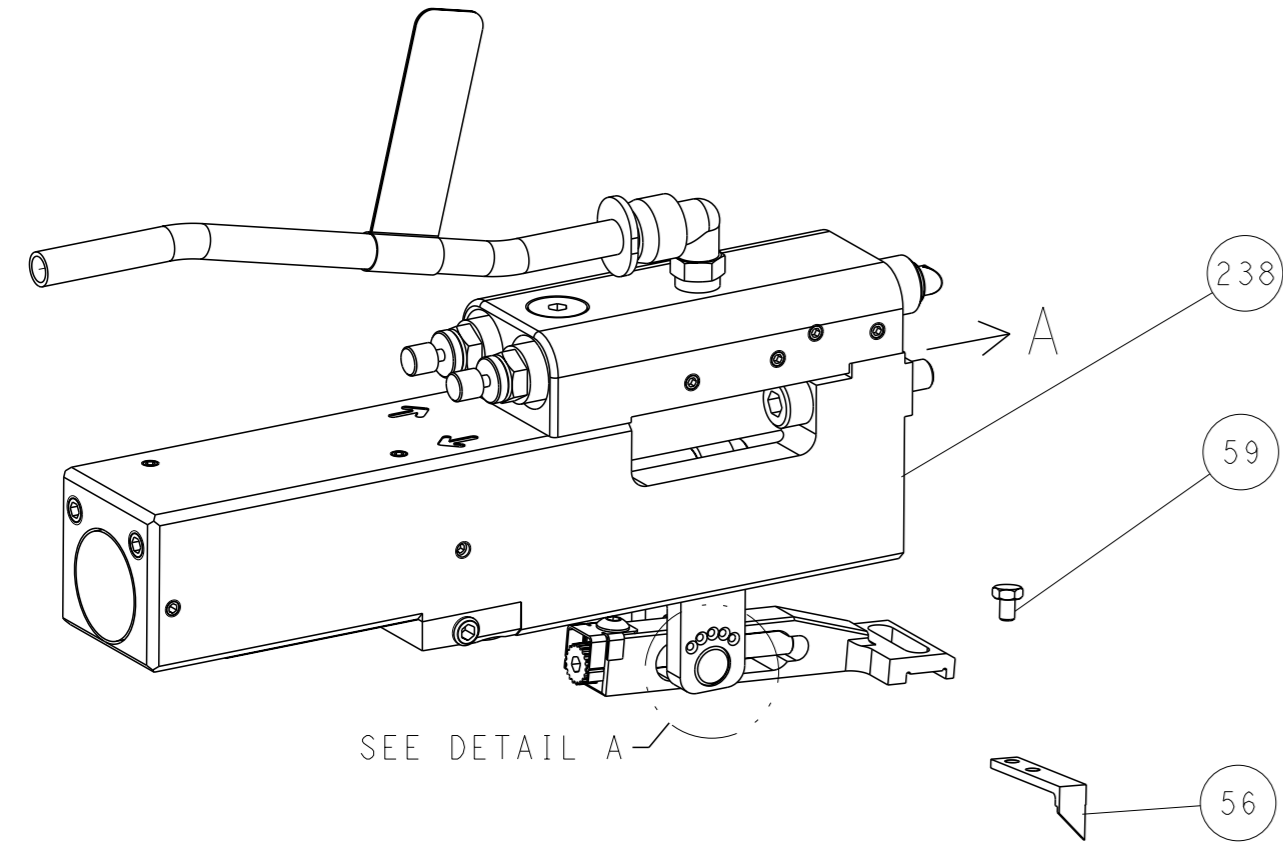

FEED SPRING SETTING POSITION (SHOWN FROM REAR SIDE)

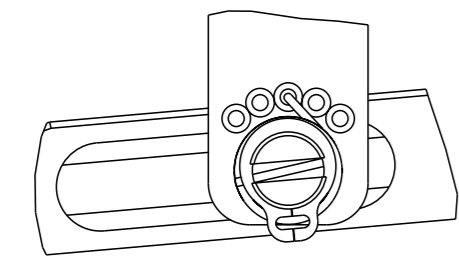

DETAIL A

CAM POSITIONS

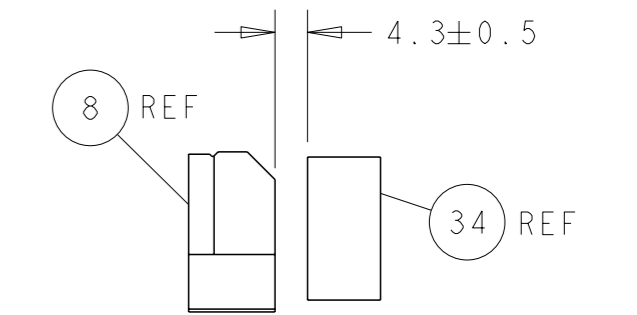
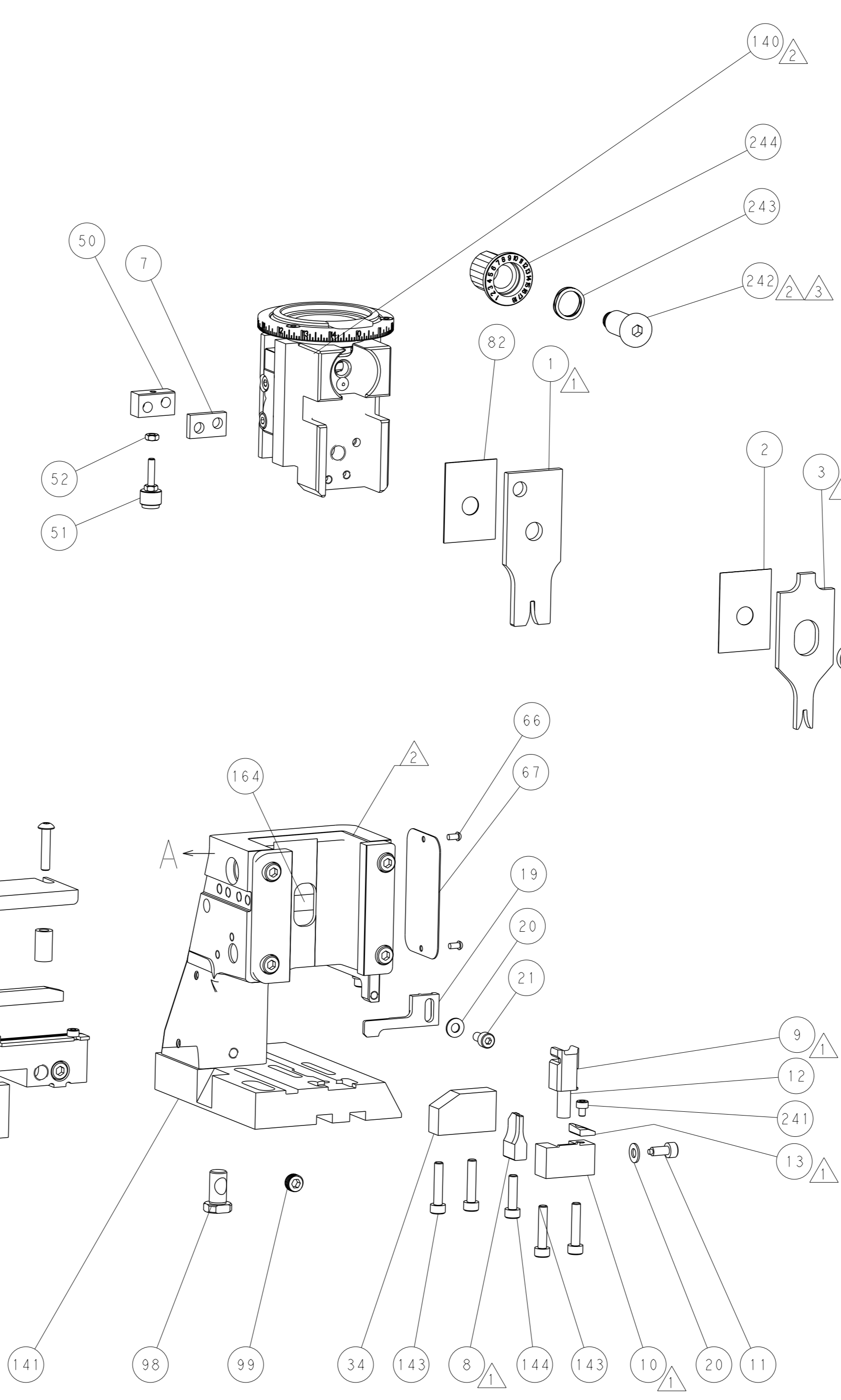
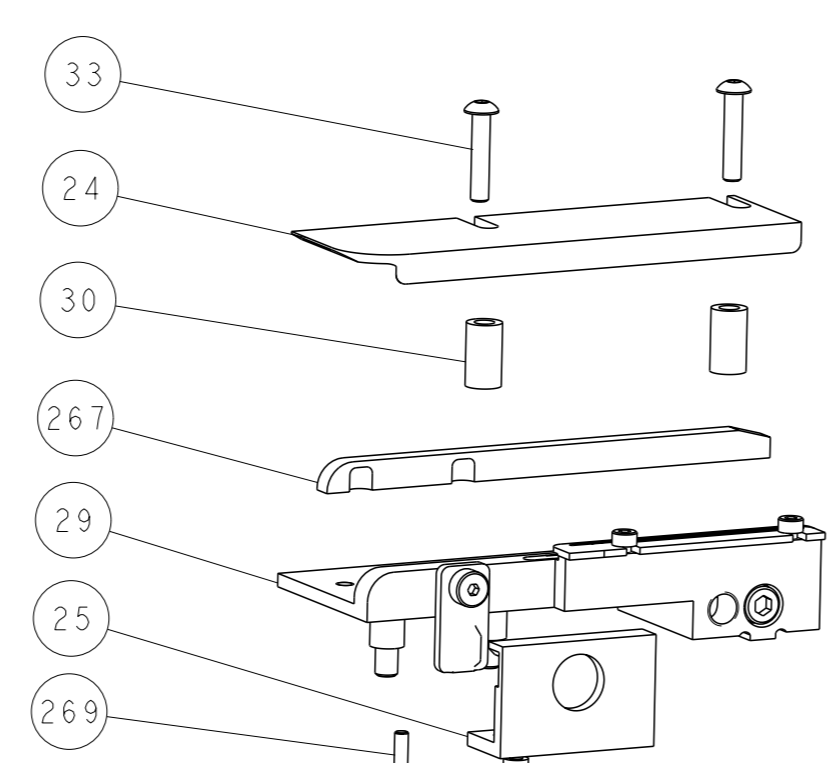
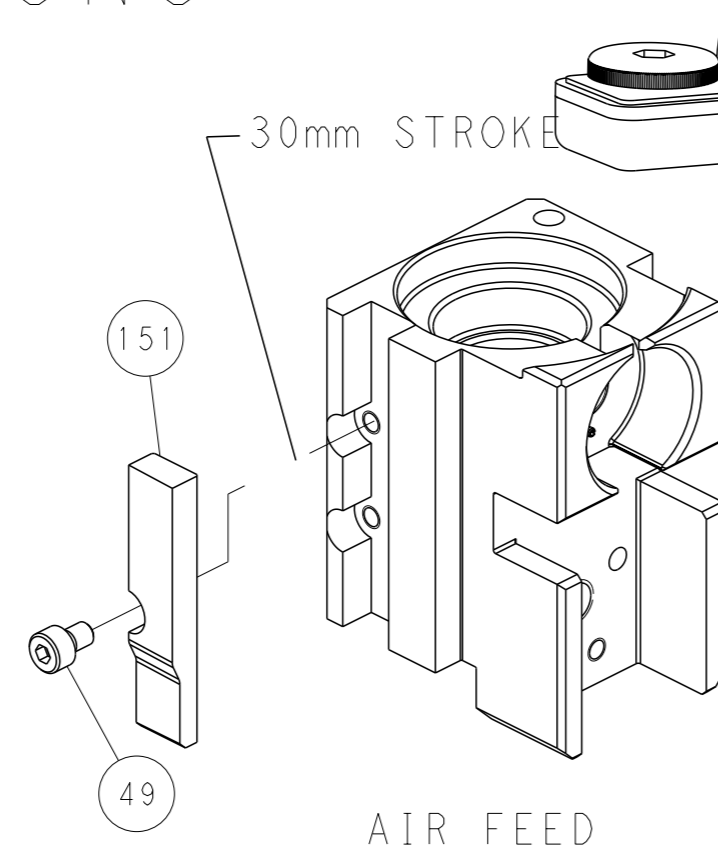
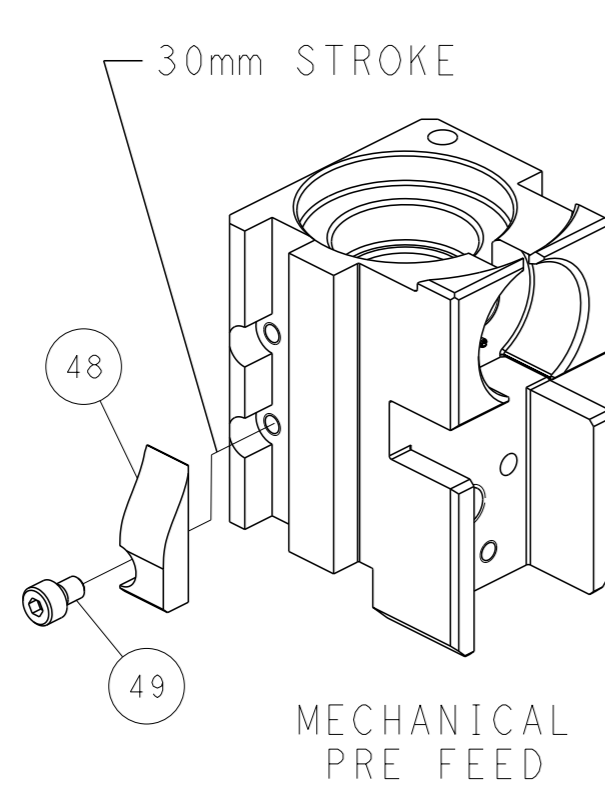
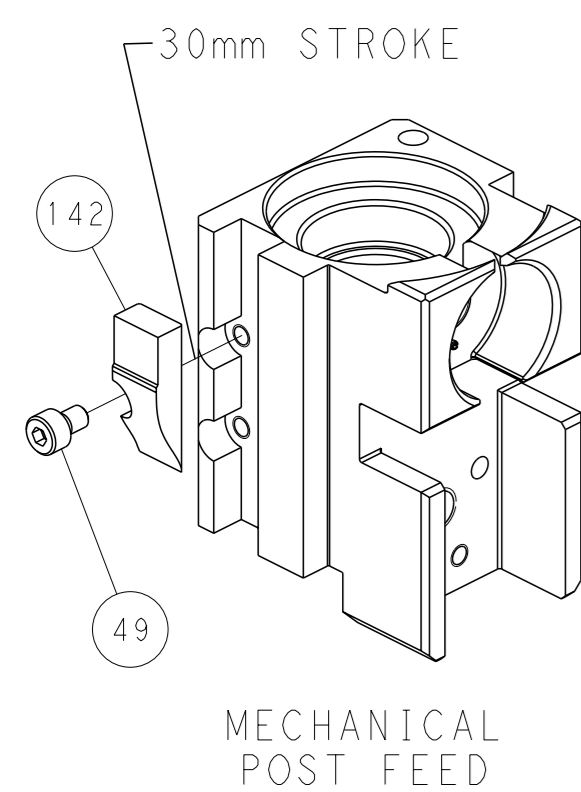

TERMINAL SUPPORT LOCATION

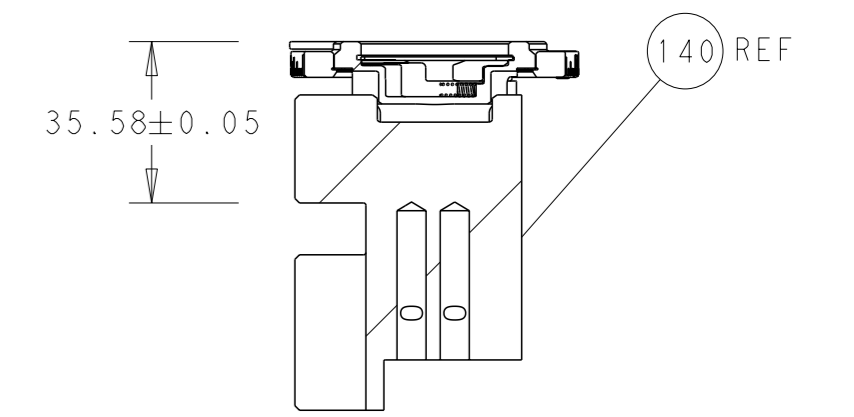

RAM SET-UP

ITEM 30 LOCATED AT
FRONT HOLES

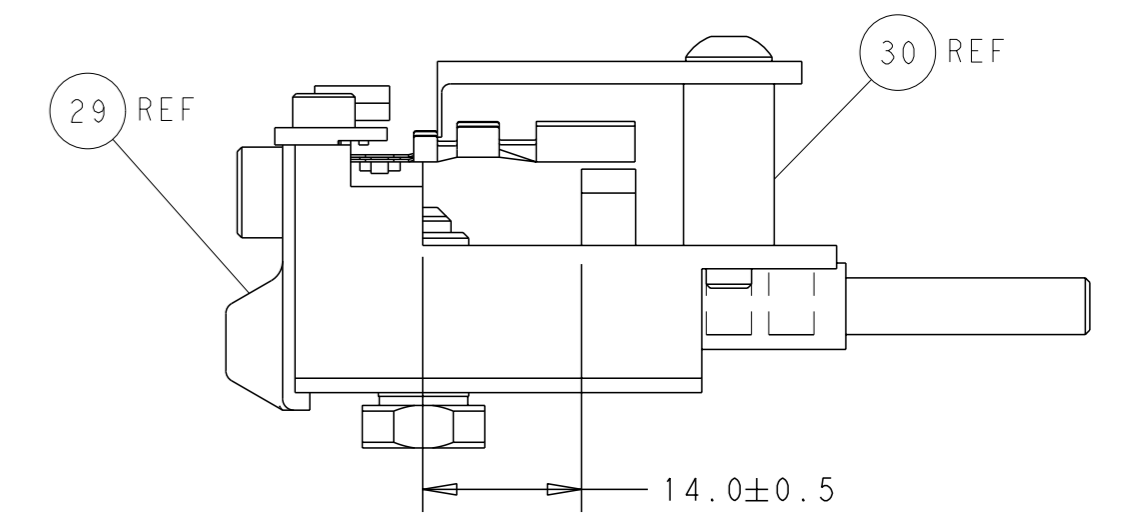

FEED TRACK POSITION
GUIDE BY INSULATION BARREL

PACIFIC VERSION
 Shown on sheets 3 of 4 & 4 of 4
 (Atlantic version shown on sheets 1 of 4 & 2 of 4)

<small>THIS DRAWING IS A CONTROLLED DOCUMENT FOR TYCO ELECTRONICS CORPORATION. IT IS SUBJECT TO CHANGE AND THE CONTROLLER'S ENGINEERING DEPARTMENT SHOULD BE CONTACTED FOR THE LATEST REVISION.</small>		DWN: M. RILEY 21OCT2015 CHK: G. BAILEY 12MAR2014 APVD: D. STOUGH 21OCT2015	NAME: Ocean Side Feed Applicator SIZE: A1 CAGE CODE: 00779 DRAWING NO: 2836063	RESTRICTED TO: B
DIMENSIONS: mm TOLERANCES UNLESS OTHERWISE SPECIFIED: 0 PLC ± 1 PLC ± 2 PLC ± 3 PLC ± 4 PLC ± ANGLES FINISH ±	WEIGHT: - SCALE: 1:2	SHEET: 4 of 4	REV: B	CUSTOMER ACCESSIBLE PRODUCTION DRAWING