

PAGE 1/2	ISSUE 01-07-15B	SERIES SMA	PART NUMBER R125072080
----------	-----------------	------------	------------------------

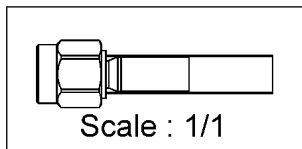

All dimensions are in mm.

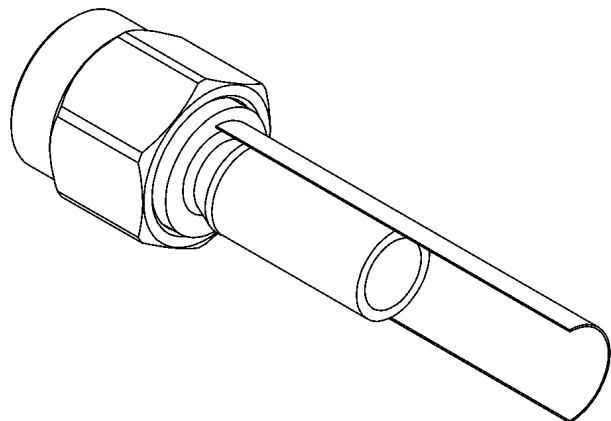
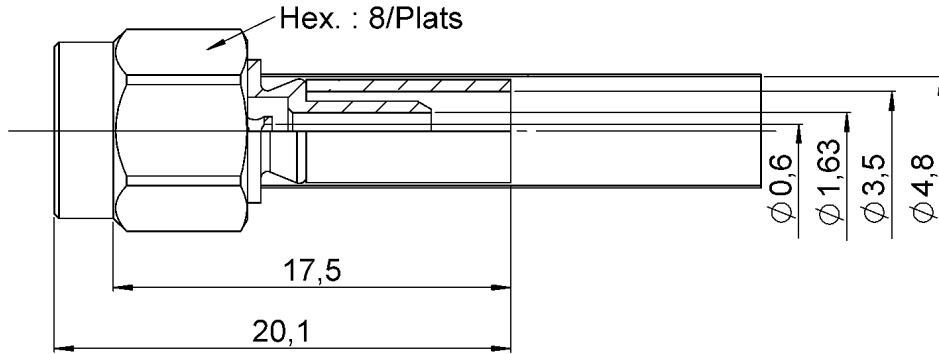
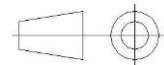

COMPONENTS	MATERIALS	PLATING (µm)
Body	<b>STAINLESS STEEL.</b>	<b>GOLD 0.5 OVER NICKEL 2</b>
Center contact	<b>BRASS</b>	<b>GOLD 1.3 OVER NICKEL2</b>
Outer contact	-	-
Insulator	<b>PTFE</b>	
Gasket	<b>SILICONE RUBBER</b>	
Others parts	<b>STAINLESS STEEL.</b>	<b>GOLD 0.5 OVER NICKEL 2</b>
-	-	-
-	-	-

PAGE 2/2	ISSUE 01-07-15B	SERIES SMA	<b>PART NUMBER R125072080</b>
----------	-----------------	------------	-------------------------------

**PACKAGING**

Standard <b>100</b>	Unit <b>Contact us</b>	Other <b>Contact us</b>
------------------------	---------------------------	----------------------------

**ELECTRICAL CHARACTERISTICS**

Impedance	<b>50</b>	Ω
Frequency	<b>0-12.4</b>	GHz
VSWR	<b>1.15 + 0,0200</b>	x F(GHz) Maxi
Insertion loss	<b>0.06</b>	√F(GHz) dB Maxi
RF leakage	- ( <b>60</b> )	- F(GHz)) dB Maxi
Voltage rating	<b>250</b>	Veff Maxi
Dielectric withstanding voltage	<b>750</b>	Veff mini
Insulation resistance	<b>5000</b>	MΩ mini

**MECHANICAL CHARACTERISTICS**

Center contact retention		
Axial force – Mating End	<b>NA</b>	N mini
Axial force – Opposite end	<b>27</b>	N mini
Torque	<b>NA</b>	N.cm mini
Recommended torque		
Mating	<b>100</b>	N.cm
Panel nut	<b>NA</b>	N.cm
Clamp nut	<b>NA</b>	N.cm
A/F clamp nut	<b>0,0000</b>	mm
Mating life	<b>500</b>	Cycles mini
Weight	<b>3,1060</b>	g

**ENVIRONMENTAL**

Operating temperature	<b>-65/+165</b>	°C
Hermetic seal	<b>NA</b>	Atm.cm3/s
Panel leakage	<b>NA</b>	

**SPECIFICATION**

**CABLE ASSEMBLY**

Stripping	a	b	c	d	e	f
mm	<b>2</b>	<b>7</b>	<b>9</b>	<b>0</b>	<b>7</b>	<b>0</b>

Assembly instruction:

Recommended cable(s)  
**K02252D**  
**RD 316**  
**ECO 316 D**

Characteristics indicated on this data sheet are those that can be achieved with the highest performance cable. Intrinsic limitations of the cable may diminish the performance of the assembly

Cable retention

- pull off	<b>110</b>	N mini
- torque	<b>NA</b>	N.cm

**TOOLING**

Part Number	Description	Hexagon
R282271000	CRIMPING TOOL	3.84
R282293000	CRIMPING TOOL M22520/5-01	-
R282235037	CRIMPING DIES	3.84

**OTHER CHARACTERISTICS**

-