



MAX9788 Evaluation Kit

General Description

The MAX9788 evaluation kit (EV kit) is a fully assembled and tested PCB that uses the MAX9788 Class G amplifier to drive a bridge-tied-load (BTL) ceramic speaker in portable audio applications. Designed to operate from a 2.7V to 5.5VDC power supply, the EV kit accepts a single-ended or differential input signal and provides a fully differential output capable of delivering greater than 14V_{P-P} into a ceramic speaker.

Component List

DESIGNATION	QTY	DESCRIPTION
C1, C2, C3	3	0.1 μ F \pm 10%, 6.3V X5R ceramic capacitors (0402) Murata GRM155R60J104K
C5, C6	2	1 μ F \pm 10%, 6.3V X5R ceramic capacitors (0402) Murata GRM155R60J105K
C7	1	4.7 μ F \pm 10%, 6.3V X5R ceramic capacitor (0603) Murata GRM188R60J475K
C8, C9, C10	3	10 μ F \pm 20%, 6.3V X5R ceramic capacitors (0603) Murata GRM188R60J106M
C11, C12	0	Not installed, capacitors (0603)
JU1	1	3-pin header
OUT	1	3.5mm stereo phone jack (3-position, non-switch)
R1-R4	4	10k Ω \pm 0.5% precision thick-film chip resistors (0603) Panasonic ERJ3RBD1002V
R5	1	100k Ω \pm 1% resistor (0603)
R6, R7	2	5.1 Ω \pm 5% resistors (0805)
U1	1	MAX9788EBP+ (20-bump, 4 x 5 UCSP, 2mm x 2.5mm)
—	1	Shunt
—	1	PCB: MAX9788EVKIT+

Features

- ◆ 5V Single-Supply Operation
- ◆ Fully Differential Output
- ◆ Delivers Greater than 14V_{P-P} into a Ceramic Speaker
- ◆ Evaluates the MAX9788 in a 20-Bump UCSP (2mm x 2.5mm) Package
- ◆ The MAX9788 IC Also Available in 28-Pin (4mm x 4mm) TQFN Package
- ◆ Fully Assembled and Tested

Ordering Information

PART	TEMP RANGE	IC PACKAGE
MAX9788EVKIT+	0°C to +70°C*	20 UCSP-20 (2mm x 2.5mm)

+Denotes a lead-free and RoHS-compliant EV kit.

*This limited temperature range applies to the EV kit PCB only. The MAX9788 IC temperature range is -40°C to +85°C.

Component Suppliers

SUPPLIER	PHONE	WEBSITE
Murata Mfg. Co., Ltd.	770-436-1300	www.murata.com
Panasonic Corp.	714-373-7366	www.panasonic.com

Note: Indicate that you are using the MAX9788 when contacting these component suppliers.

Evaluates: MAX9788

MAX9788 Evaluation Kit

Quick Start

Recommended Equipment

- 5V, 1A power supply
- Audio source (i.e., CD player, MP3 player)
- One ceramic speaker (recommended suppliers: Murata, Taiyo Yuden)

Procedure

The MAX9788 EV kit is fully assembled and tested. Follow the steps below to verify board operation.

Caution: Do not turn on the power supply until all connections are completed.

- 1) Install a shunt across pins 1-2 of jumper JU1 (EV kit ON).
- 2) Connect the ceramic speaker across the OUT- and OUT+ pads.
- 3) Connect the positive terminal of the power supply to the VCC pad and the ground terminal to the GND pad.
- 4) Connect the positive terminal of the audio source to the IN+ pad.
- 5) Connect the negative terminal of the audio source to the IN- pad. Connect the IN- pad to GND if the audio source is single ended.
- 6) Connect the ground terminal of the audio source to the GND pad.
- 7) Turn on the audio source.
- 8) Turn on the power supply.

Detailed Description

The MAX9788 EV kit features the MAX9788 Class G amplifier IC, designed to drive a ceramic speaker in a BTL configuration. The EV kit operates from a DC power supply that provides 2.7V to 5.5V and 1A of current.

The EV kit accepts single-ended or a differential audio input and provides a fully differential output. The audio input source is amplified to drive greater than 14V_{p-p} into a ceramic speaker.

Customizing the Gain

The MAX9788 EV kit is shipped with a gain of +12dB. Change the resistors (R1–R4) to customize the gain of the EV kit (refer to the MAX9788 IC data sheet for details).

Jumper Selection

Shutdown Mode ($\overline{\text{SHDN}}$)

Jumper JU1 controls the shutdown pin ($\overline{\text{SHDN}}$) of the MAX9788 IC. The shutdown pin is also controlled by an external logic controller connected to the EV kit $\overline{\text{SHDN}}$ pad. Remove the shunt from jumper JU1 before connecting an external controller to the $\overline{\text{SHDN}}$ pad. See Table 1 for shunt positions.

Table 1. Shutdown Mode, JU1 Jumper Selection

SHUNT POSITION	MAX9788 $\overline{\text{SHDN}}$ PIN CONNECTED TO	EV KIT FUNCTION
1-2*	VDD	EV kit enabled
2-3	GND	Shutdown mode
None	External logic controller	$\overline{\text{SHDN}}$ driven by external logic controller. Shutdown is active low and 1.8V logic compliant.

*Default position.

MAX9788 Evaluation Kit

Evaluates: MAX9788

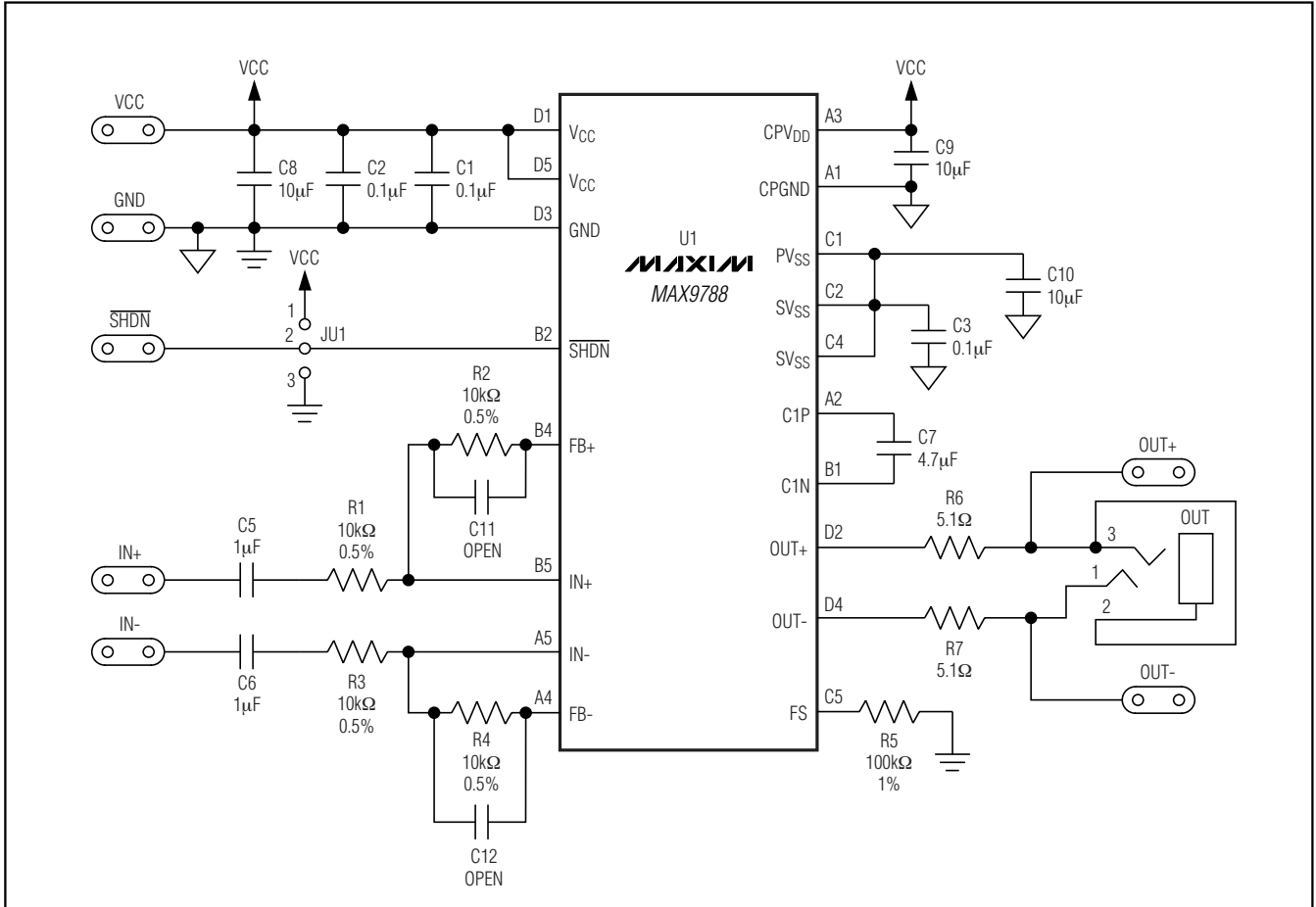

Figure 1. MAX9788 EV Kit Schematic

MAX9788 Evaluation Kit

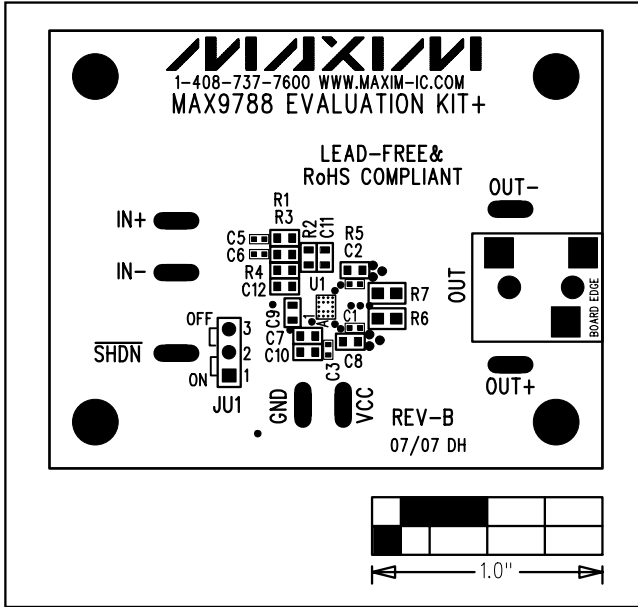

Figure 2. MAX9788 EV Kit Component Placement Guide—Component Side

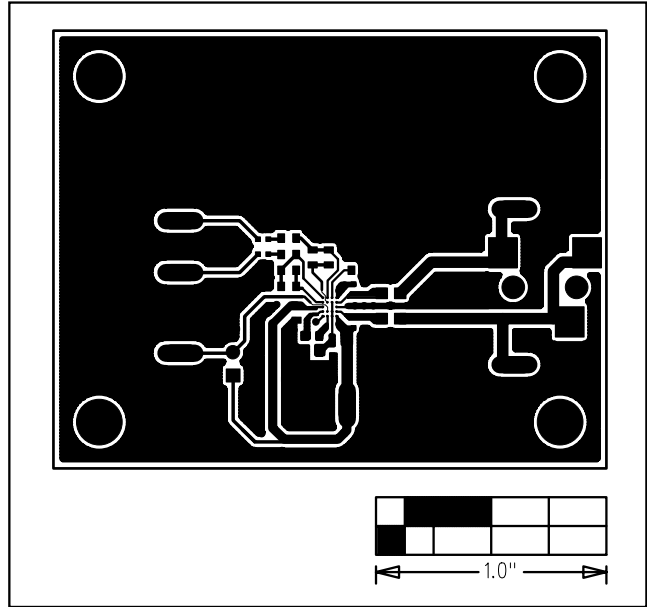

Figure 3. MAX9788 EV Kit PCB Layout—Component Side

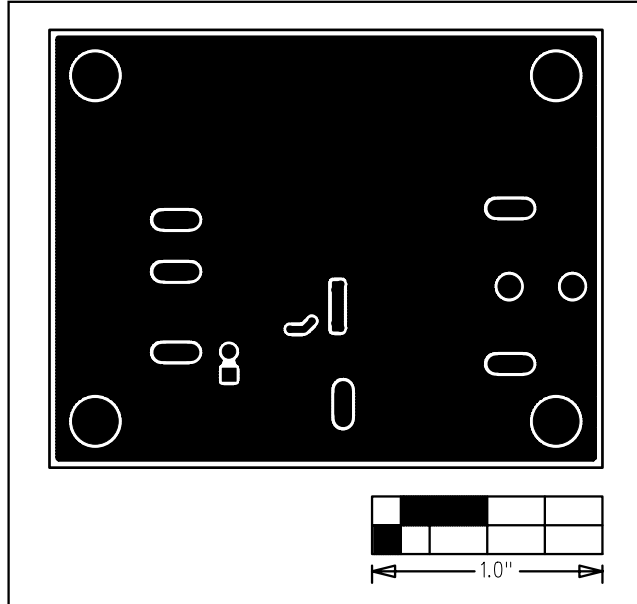

Figure 4. MAX9788 EV Kit PCB Layout—Solder Side

Revision History

Pages changed at Rev 2: 1, 3, 4

Maxim cannot assume responsibility for use of any circuitry other than circuitry entirely embodied in a Maxim product. No circuit patent licenses are implied. Maxim reserves the right to change the circuitry and specifications without notice at any time.

4 **Maxim Integrated Products, 120 San Gabriel Drive, Sunnyvale, CA 94086 408-737-7600**

© 2007 Maxim Integrated Products

MAXIM is a registered trademark of Maxim Integrated Products, Inc.