

THIS DRAWING IS SUPPLIED FOR INFORMATION ONLY. DESIGN FEATURES, SPECIFICATIONS AND PERFORMANCE DATA SHOWN HEREON ARE THE PROPERTY OF THE AMPHENOL CORPORATION. NO RIGHTS OF REPRODUCTION ARE IMPLIED. ALL DIMENSIONS ARE SUBJECT TO NORMAL MANUFACTURING VARIATIONS.

Customer Drawing

REV		ZONE	ECO	DESCRIPTION	DATE	BY	APPR
B	--	--	--	Add Locking Screw Assembly Torque	10/28/16	SW	RW
D	--	--	--	Add Rating Current	10/31/18	ST	JL
E	--	--	--	Add Model No	02/25/19	ST	JL
F	--	--	--	Change dimension tolerance of crimp barrel	06/07/21	Steven	JL
G	--	--	--	Correct dimension errors	10/14/21	Steven	JL

订购信息 Ordering Information

PL28 X - 30 1 - 70 - 5

键位及颜色 Key & Color	高压互锁 HVIL	线缆大小 Cable Size
"X", 橙色 Orange	0, 不带互锁 No HVIL	"70"=70mm ²
"Y", 黑色 Black	1, 带互锁 With HVIL	"50"=50mm ²
"U", 黄色 Yellow		"35"=35mm ²
"V", 绿色 Green		
"W", 红色 Red		
"T", 蓝色 Blue		

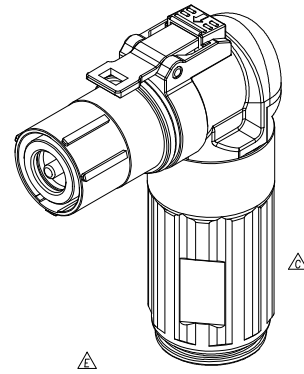
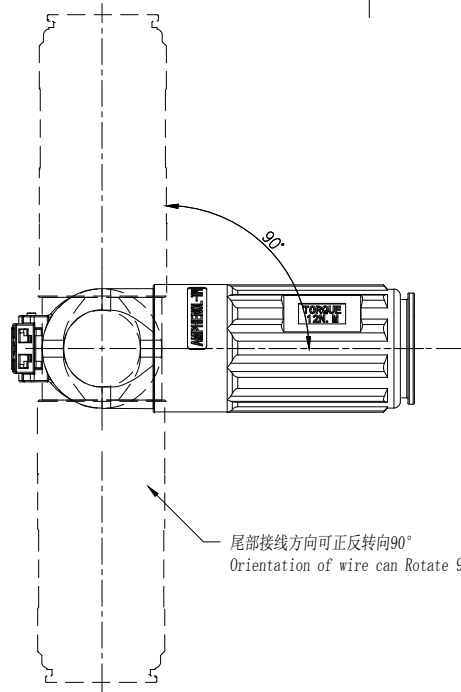

Model NO.	overall-diameter nominal (mm)	Dia Primary Insulation (mm)	outside-diameter of terminal (mm): "A"	inside-diameter of terminal (mm): "B"
PL28X-30()-35-5	12.7±0.3	9.7±0.3	11.8±0.05	8.8±0.05
PL28Y-30()-35-5				
PL28U-30()-35-5				
PL28V-30()-35-5				
PL28W-30()-35-5				
PL28T-30()-35-5	14.9±0.3	11.5±0.3	14.5±0.05	10.3±0.05
PL28X-30()-50-5				
PL28Y-30()-50-5				
PL28U-30()-50-5				
PL28V-30()-50-5				
PL28W-30()-50-5	17.0±0.3	13.7±0.3	16.5±0.05	12.5±0.05
PL28T-30()-50-5				
PL28X-30()-70-5				
PL28Y-30()-70-5				
PL28U-30()-70-5				
PL28V-30()-70-5				
PL28W-30()-70-5				
PL28T-30()-70-5				

按键颜色见“订购信息”
The color of press key see "Ordering Information"

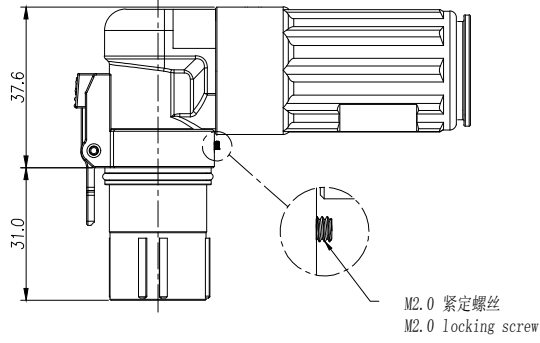
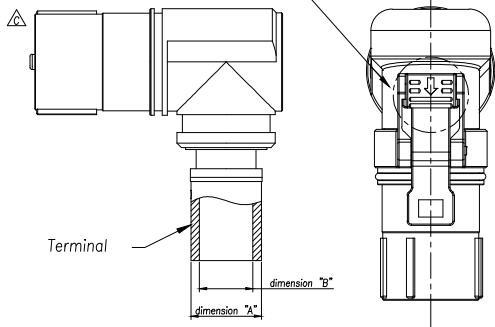

规格参数 (Spec.):

- 工作温度 Operating temperature: -40° C~+125° C.
- 额定电流 Current rating (Connector Only): 35mm²-150A, 50mm²-200A, 70mm²-250 A.
- 额定电压 Operating voltage: 1000 VDC.
- 耐电压 Dielectric withstanding voltage: 5000 VDC.
- 防护等级 Protection class: IP67 & IP2X.
- 电磁屏蔽 Shielding.
- 机械寿命 Mating cycle: 100 Min.
- 带自动二次锁扣 Automatic secondary lock.
- 尾部接线方向可正反转向90° Rotate function of wire.
- 带高压互锁 Electrical interlock (HVIL).
- 配对插座 Mating receptacle: See drawing "PL00-300"
- 拧紧螺丝锁紧扭矩 Tightening Torque of Locking Screw: 0.17±0.01 Nm

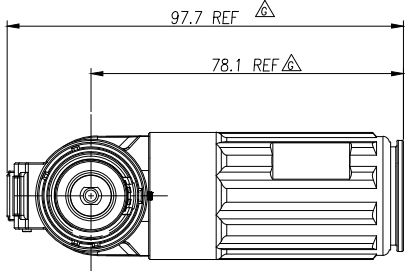

		Amphenol Technical Products International GZ				PART NAME: PwrLok 10mm-90 1POS Plug Assy	
		第三角投影 THIRD ANGLE PROJECTION	页面 SHEET	幅面 SIZE	版次 REV.	比例 SCALE	DWG NO: PL28()-30()-()-5
签名 SIGNATURE: Steven		日期 DATE: 10/14/21		UNLESS OTHERWISE SPECIFIED 1) All dimensions are in metric (mm). 2) Tolerances are as follows: 0 PL DEC ±1.00 1 PL DEC ±0.50 2 PL DEC ±0.20		CUST PART #: N/A	
制图 DRAWN: Steven		审核 CHECKED:		批准 APPROVAL:		CUST REV: -	