

PART NUMBER	REVISION	DESCRIPTION	FEED TYPE
2151678-1	E	FINE CRIMP HEIGHT ADJUST	MECHANICAL
2151678-2	E	FINE CRIMP HEIGHT ADJUST	PNEUMATIC
7-2151678-1	E	MECHANICAL AND CRIMP TOOLING KIT	MECHANICAL
7-2151678-2	E	PNEUMATIC AND CRIMP TOOLING KIT	PNEUMATIC
7-2151678-7	B	CRIMP TOOLING KIT	-

ATLANTIC VERSION TERMINATOR INTERFACE ADAPTER

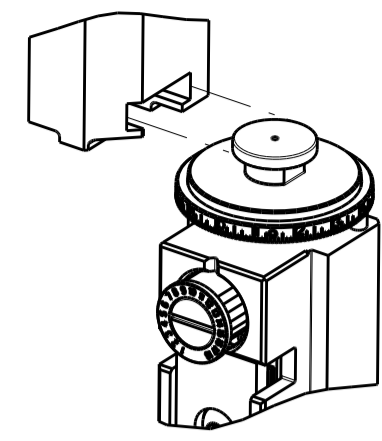

APPLICATOR DATA		
CRIMP	SIZE	TYPE
WIRE	1.07 mm [.042]	F
INSUL	1.27 mm [.050]	O

APPLICATOR INSTRUCTIONS
408-35042

TERMINAL DATA: TE TERMINAL		TE CRIMP SPECIFICATION	
TERMINAL NAME: CuNiSi UNSEALED 0.50 FEMALE CONTACTS			
WIRE STRIP LENGTH		INSULATION DIAMETER RANGE	
3.25-3.55 mm [.128-.140 IN]		Ø1.10-1.40 mm [.043-.055 IN]	
TERMINAL APPLICATION SPECIFICATION	114-13287		
TERMINALS APPLIED			
TE TERMINAL	TE TERMINAL	TE TERMINAL	TE TERMINAL
2098583-2			

WIRE SIZE	CRIMP HEIGHT mm [INCH]	CRIMP HEIGHT REFERENCE SETTING
0.35mm2	0.70 +/- 0.02 [.028 +/- .001]	9.5

- 1. RECOMMENDED SPARE PARTS
- 2. REFER TO SUPPLIED INSTRUCTION SHEET FOR CLEANING, LUBRICATION AND STORAGE OF APPLICATOR.
- 3. APPLY PART NUMBER 2-23419-6 LOCTITE TO THREADS OF ITEM 242.
- 4. CRIMP HEIGHT REFERENCE SETTING WAS THE SETTING USED WHEN THE APPLICATOR WAS QUALIFIED AT THE FACTORY. ADJUSTMENT MAY BE NECESSARY WHEN RUNNING APPLICATOR IN THE FIELD.
- 5. UNLESS SPECIFIED OTHERWISE TORQUE VALUES SHALL BE USED PER DOCUMENT, 101-35000.

***WARNING**
ON INSTALLATION, SET WIRE DISC TO CRIMP HEIGHT REFERENCE SETTING FOR LARGEST WIRE SIZE. CRIMP HEIGHT REFERENCE SETTINGS GREATER THAN THE VALUE SHOWN MAY CAUSE DAMAGE TO THE CRIMP TOOLING, REFER TO THE INSTRUCTION SHEET FOR PROPER SETUP AND ADJUSTMENTS.

ATLANTIC VERSION
Shown on sheets 1 of 4 & 2 of 4
(Pacific version shown on sheets 3 of 4 & 4 of 4)

LOC	DIST	REVISIONS					
A	66	P	LTN	DESCRIPTION	DATE	OWN	APVD
		B		ECR-16-003119	01MAR2016	KH	TE
		C		ECR-16-005510	14APR2016	RK	JD
		D		ECR-17-006970	15MAY2017	FZ	KZ
		E		ECR-19-013036	20AUG2019	FZ	TE

-	1	1	1	1	2-1722335-1	THREAD BOLT GEWINDEBOLZEN	261
-	1	-	1	-	2119641-1	FEED CAM, AIR FEED	248
-	1	1	1	1	2119082-7	CAM, SNAIL, INSULATION ADJUSTMENT	244
-	1	1	1	1	2079764-1	WASHER, WAVE SPRING, CREST-TO-CREST	243
-	1	1	1	1	2119083-1	RETAINER, INSULATION DIAL	242
-	1	1	1	1	7-18023-7	SCR, SKT HD CAP M3 X 4.0	241
-	-	1	-	1	2119580-1	MECHANICAL FEED ASSEMBLY	239
-	1	-	1	-	2844940-1	AIR FEED MODULE	238
-	1	1	1	1	455053-2	PLATE, RETAINING	180
-	1	1	1	1	4-21028-0	PIN, SLOTTED SPRING .094 X .750	177
-	2	2	2	2	22278-9	SPRING, COMPRESSION	176
-	1	1	1	1	1803129-1	PLATE, RETAINER	175
-	REF	REF	REF	REF	994970-2	COUNTER, MAGNETIC	164
-	1	1	1	1	1-22281-8	SPRING, COMPRESSION	121
-	1	1	1	1	1-18028-2	WASHER, FLAT, REG M4	119
-	1	1	1	1	2844908-1	SCREW, LOCKING	99
-	1	1	1	1	2844907-1	POST, LOCKING	98
-	1	1	1	1	1-690438-0	FRONT STRIP GUIDE	96
-	2	2	2	2	2168083-1	SCR, SKT HD CAP, RoHS, M3 X 8.0	95
-	1	1	1	1	2168083-6	SCR, SKT HD CAP, RoHS, M5 X 65	93
-	1	1	1	1	455888-5	SPACER, CRIMPER	82
-	1	1	1	1	1803607-3	DOCUMENTATION PACKAGE	71
-	1	1	1	1	2119791-9	DEPRESSOR, WIRE	70
-	1	1	1	1	2119740-1	TAG, IDENTIFICATION	67
-	2	2	2	2	2168078-1	SCREW, DRIVE, RH, RoHS, 2 x .188	66
-	1	1	1	1	2-18032-5	SCR, SET, FLT PNT, M5 X 20.0	61
-	1	1	1	1	2168083-2	SCR, SKT HD CAP, RoHS, M4 X 8.0	60
-	1	1	1	1	5-18022-5	SCR, HEX HD CAP, M4 X 6.0	59
-	1	1	1	1	1338685-1	PAWL, FEED	56
-	4	4	4	4	2168083-3	SCR, SKT HD CAP, RoHS, M4 X 12.0	54
-	2	2	2	2	1-2168083-2	SCR, SKT HD CAP, RoHS, M4 X 25	53
-	1	1	1	1	18031-1	SCR, SET, CUP POINT M3 X 5.0	52
-	1	1	1	1	1424303-2	HOLDER, TERMINAL	51
-	1	1	1	1	455052-3	CARRIER, HOLD DOWN	50
-	1	2	1	2	18023-9	SCR, SKT HD CAP M4 X 6.0	49
-	-	1	-	1	2119652-1	FEED CAM, PRE FEED	48
-	-	1	-	1	2119653-1	FEED CAM, POST FEED	47
-	1	1	1	1	1803583-9	APPLICATOR BASIC ASSEMBLY, SF	46
-	1	1	1	1	1803515-1	RAM ASSEMBLY, SF ATLANTIC	44
-	1	1	1	1	1803602-1	SCR, BHSC, RoHS (M8 X 25)	41
-	1	1	1	1	5-1752356-5	SUPPORT, TERMINAL	34
-	2	2	2	2	2079383-5	SCR, BHSC, RoHS (M4 X 20)	33
-	2	2	2	2	2-2844962-4	SPACER, CYLINDRICAL, STRIP GUIDE	30
-	1	1	1	1	2844938-1	PLATE, STRIP GUIDE	29
-	2	2	2	2	22283-1	SPRING, COMPRESSION	27
-	1	1	1	1	356835-1	LEVER, DRAG RELEASE	26
-	1	1	1	1	1803142-1	DRAG, TERMINAL	25
-	1	1	1	1	1320928-2	STRIP GUIDE	24
-	1	1	1	1	980371-4	SCR, SKT HD SHLDR 5.0 DIA X 6.0	23
-	1	1	1	1	2168083-2	SCR, SKT HD CAP, RoHS, M4 X 8.0	21
-	1	1	1	1	1-18028-2	WASHER, FLAT, REG M4	20
-	1	1	1	1	2119533-3	STRIPPER, SIDE FEED	19
-	1	1	1	1	2119806-1	INSERT, SHEAR	13
-	1	1	1	1	3-22280-3	SPRING, COMPRESSION	12
-	1	1	1	1	1-356885-4	STOP, SHEAR	11
-	1	1	1	1	2119805-1	SHEAR HOLDER, FRONT	10
-	1	1	1	1	1633861-3	SHEAR, FLOATING	9
-	1	2	2	1	1-1633916-2	ANVIL, COMBINATION	8
-	1	1	1	1	240641-9	SPACER	7
-	-	-	-	-	-	-	6
-	1	1	1	1	2119757-8	DEPRESSOR, SHEAR	5
-	1	1	1	1	4-238011-1	BLOCK, CRIMPER SPACER	4
-	1	2	2	1	1633966-5	CRIMPER, INSULATION O	3
-	-	-	-	-	-	-	2
-	1	2	2	1	456401-3	CRIMPER, WIRE .042 F PREMIUM	1
-	77	72	71	2	-1	PART NO	ITEM NO
-						DESCRIPTION	

DIMENSIONS:		TOLERANCES UNLESS OTHERWISE SPECIFIED:		MATERIAL:		FINISH:	
mm	0 PLC	±					
	1 PLC	±					
	2 PLC	±					
	3 PLC	±					
	4 PLC	±					
	ANGLES	±					

OWN	C. MOYER	01JAN2012	TE Connectivity Harrisburg, PA 17105-3608
CHK	T. ELBIN	01JAN2012	
APVD	T. ELBIN	01JAN2012	
NAME			Ocean Side Feed Applicator
PRODUCT SPEC			
APPLICATION SPEC			
SIZE	CAGE CODE	DRAWING NO	RESTRICTED TO
A1	00779	2151678	
Customer Accessible Production Drawing			SCALE 1:2 SHEET 1 OF 4 REV E

LOC		DIST		REVISONS			
A	66	P	LYN	DESCRIPTION	DATE	OWN	APVD
		-		SEE SHEET 1			

FEED TYPE MECHANICAL

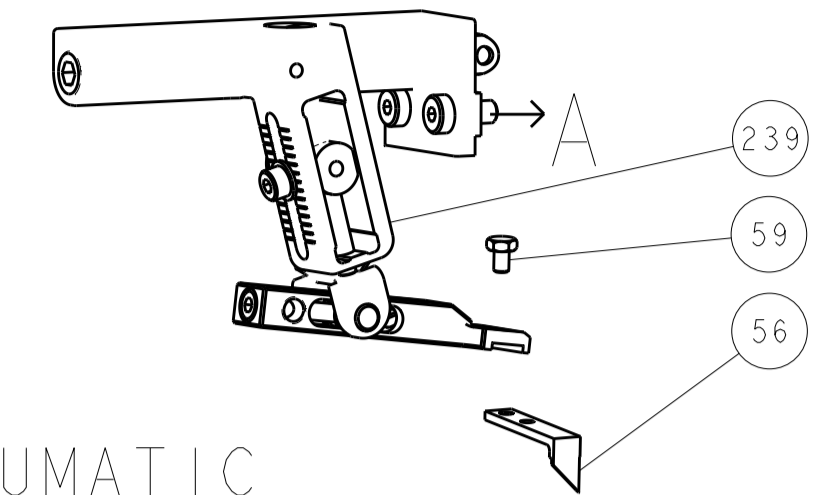

PNEUMATIC

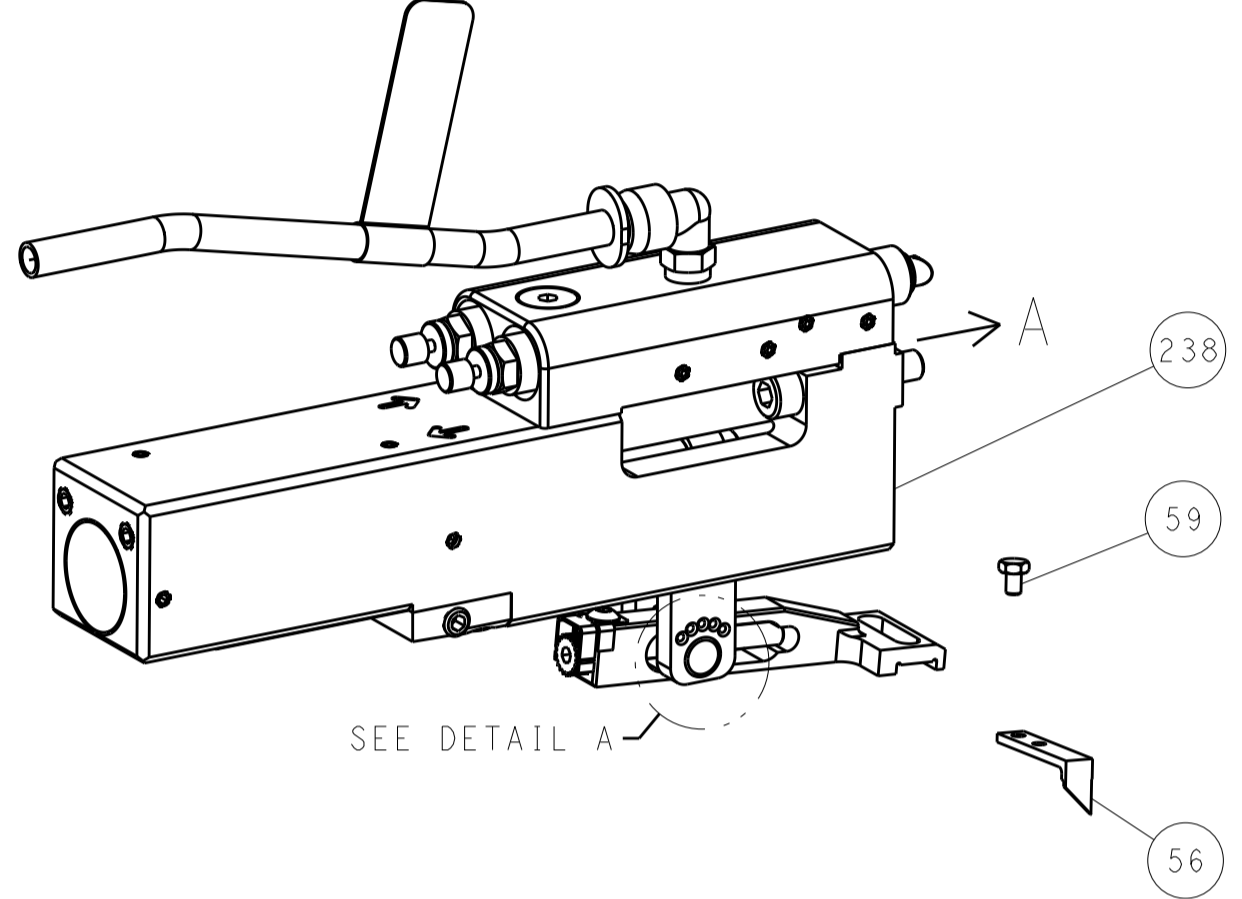

FEED SPRING SETTING POSITION (SHOWN FROM REAR SIDE)

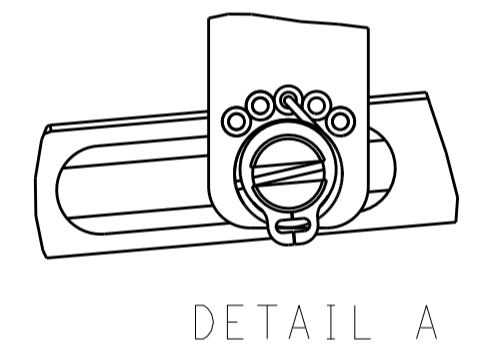

DETAIL A

CAM POSITIONS

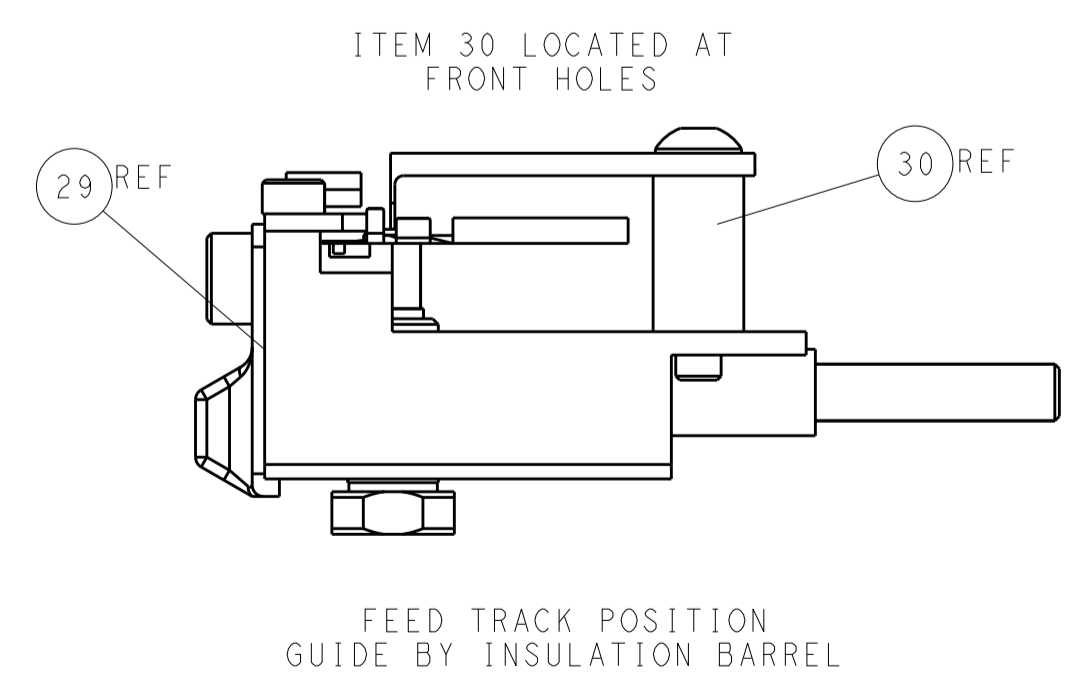
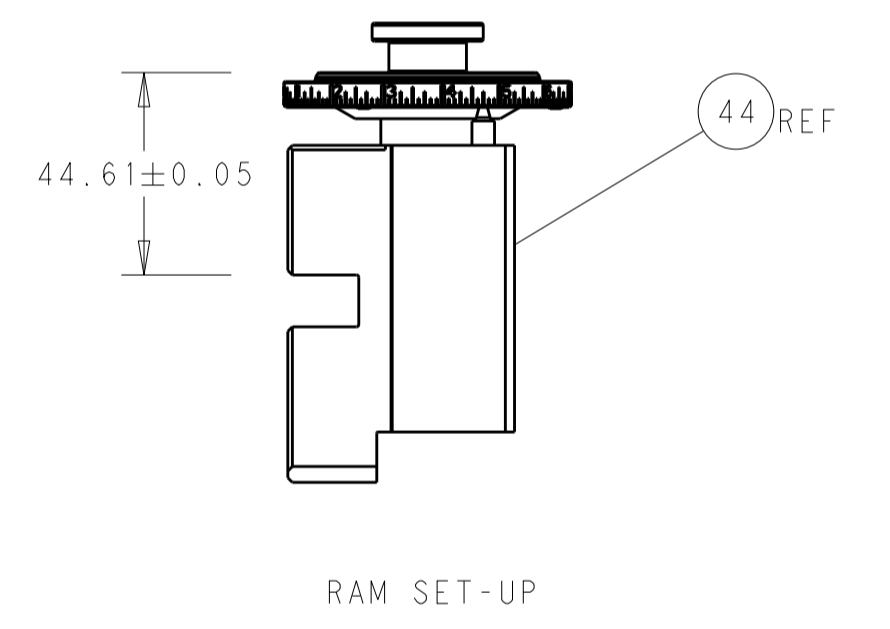
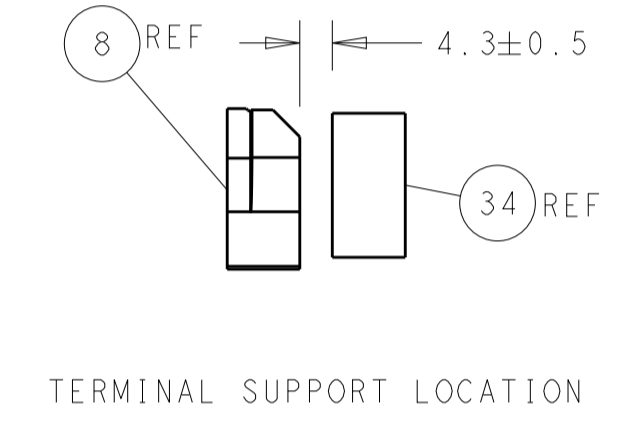
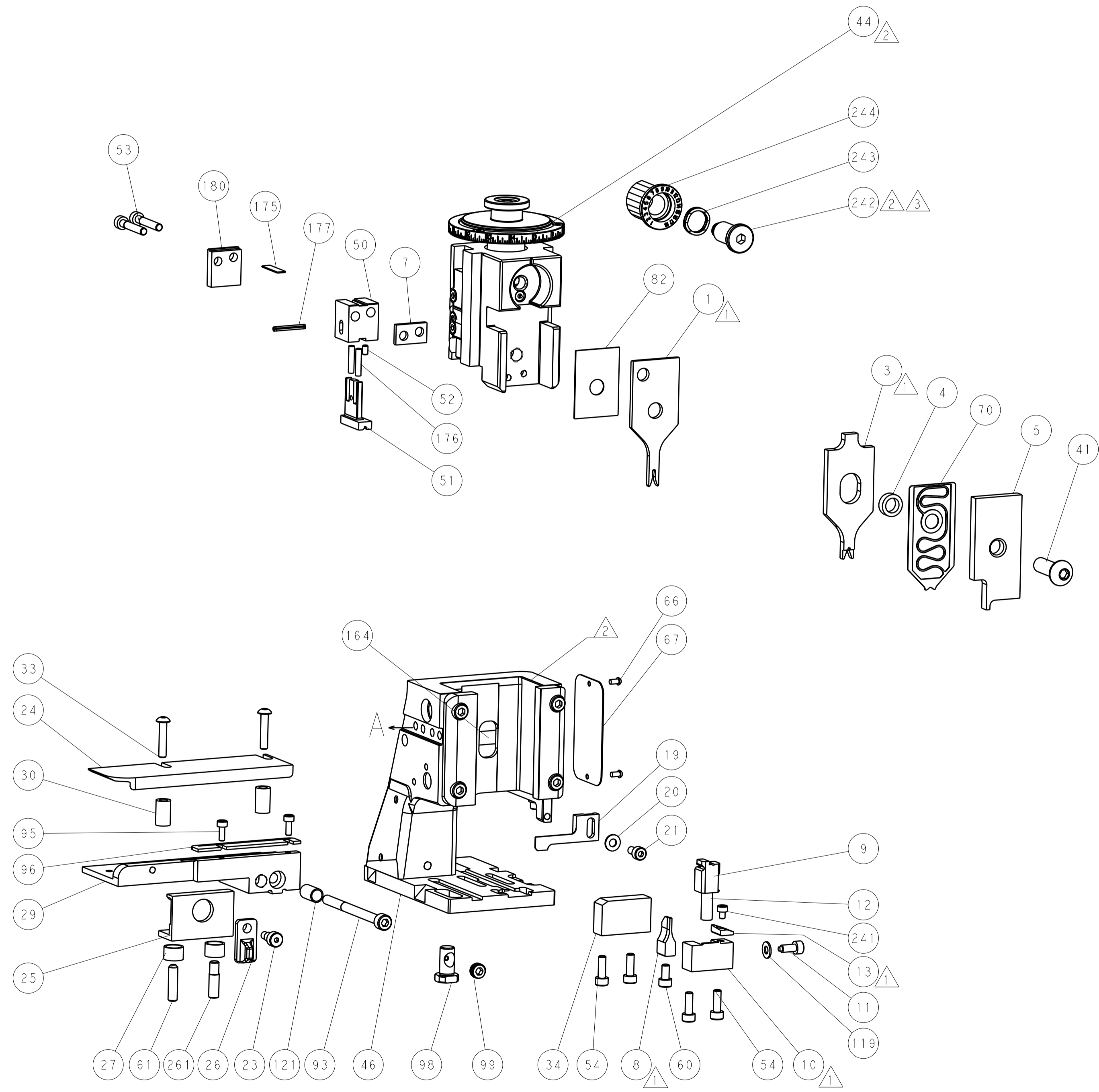
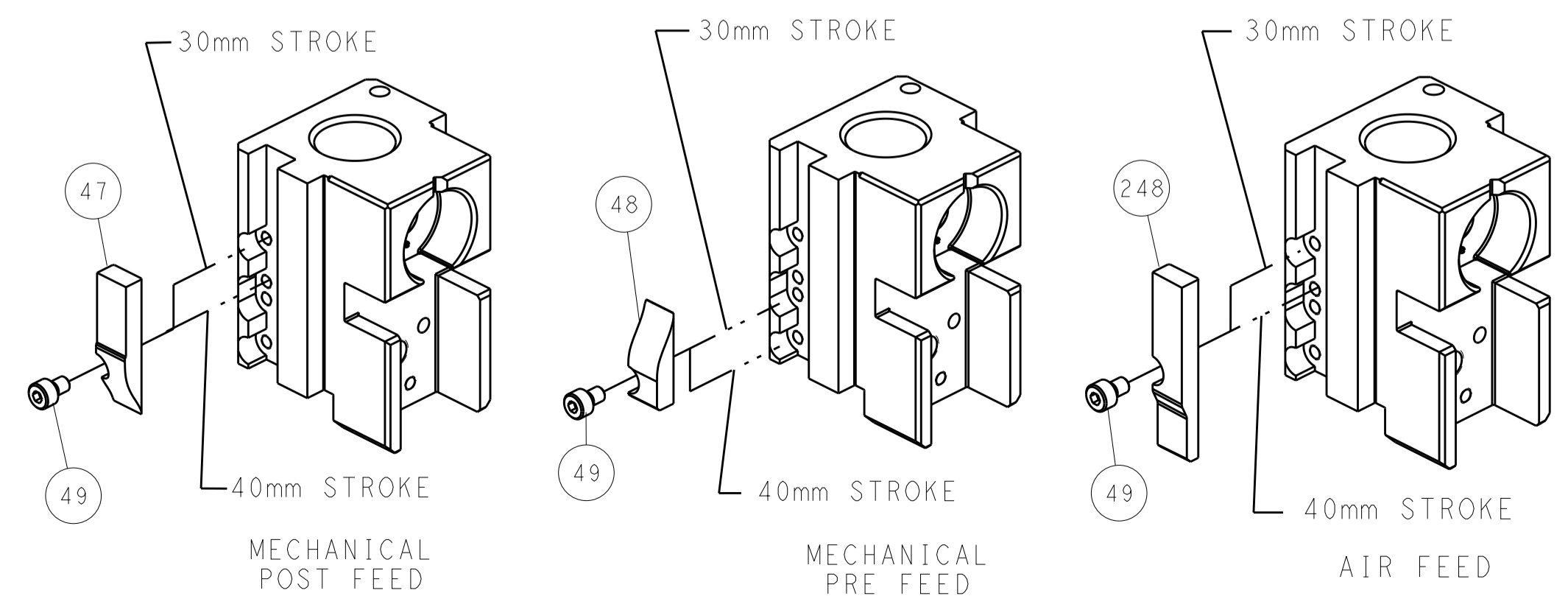

ATLANTIC VERSION
 Shown on sheets 1 of 4 & 2 of 4
 (Pacific version shown on sheets 3 of 4 & 4 of 4)

DIMENSIONS:		TOLERANCES UNLESS OTHERWISE SPECIFIED:		DWN C. MOYER 01JAN2012		TE Connectivity	
mm	0 PLC	±		CHK T. ELBIN 01JAN2012	Harrisburg, PA 17105-3608		
	1 PLC	±		APVD T. ELBIN 01JAN2012	NAME Ocean Side Feed		
	2 PLC	±			Applicator		
	3 PLC	±			SIZE CAGE CODE DRAWING NO RESTRICTED TO		
	4 PLC	±			A1 00779 ©=2151678		
MATERIAL	FINISH	WEIGHT		Customer Accessible Production Drawing		SCALE	1:2 SHEET 2 OF 4 REV E

PART NUMBER	REVISION	DESCRIPTION	FEED TYPE
2-2151678-1	E	FINE CRIMP HEIGHT ADJUST	MECHANICAL
2-2151678-2	E	FINE CRIMP HEIGHT ADJUST	PNEUMATIC
7-2151678-7	B	CRIMP TOOLING KIT	-

PACIFIC VERSION TERMINATOR
INTERFACE ADAPTER

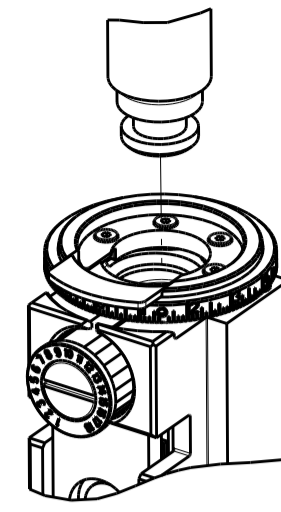

APPLICATOR DATA		
CRIMP	SIZE	TYPE
WIRE	1.07 mm [.042]	F
INSUL	1.27 mm [.050]	O
APPLICATOR INSTRUCTIONS 408-35042		

TERMINAL DATA: TE TERMINAL		TE CRIMP SPECIFICATION
TERMINAL NAME: CuNiSi UNSEALED 0.50 FEMALE CONTACTS		
WIRE STRIP LENGTH 3.25-3.55 mm [1.28-.140 IN]		INSULATION DIAMETER RANGE Ø1.10-1.40 mm [.043-.055 IN]
TERMINAL APPLICATION SPECIFICATION 114-13287		
TERMINALS APPLIED		
TE TERMINAL	TE TERMINAL	TE TERMINAL
2098583-2		

WIRE SIZE	CRIMP HEIGHT mm [INCH]	CRIMP HEIGHT REFERENCE SETTING
0.35mm ²	0.70 +/- 0.02 [.028 +/- .001]	9.5



- △ RECOMMENDED SPARE PARTS
- △ REFER TO SUPPLIED INSTRUCTION SHEET FOR CLEANING, LUBRICATION AND STORAGE OF APPLICATOR.
- △ APPLY PART NUMBER 2-23419-6 LOCTITE TO THREADS OF ITEM 242.
- △ CRIMP HEIGHT REFERENCE SETTING WAS THE SETTING USED WHEN THE APPLICATOR WAS QUALIFIED AT THE FACTORY. ADJUSTMENT MAY BE NECESSARY WHEN RUNNING APPLICATOR IN THE FIELD.
- 5. UNLESS SPECIFIED OTHERWISE TORQUE VALUES SHALL BE USED PER DOCUMENT, 101-35000.

***WARNING**
ON INSTALLATION, SET WIRE DISC TO CRIMP HEIGHT REFERENCE SETTING FOR LARGEST WIRE SIZE. CRIMP HEIGHT REFERENCE SETTINGS GREATER THAN THE VALUE SHOWN MAY CAUSE DAMAGE TO THE CRIMP TOOLING, REFER TO THE INSTRUCTION SHEET FOR PROPER SETUP AND ADJUSTMENTS.

PACIFIC VERSION
Shown on sheets 3 of 4 & 4 of 4
(Atlantic version shown on sheets 1 of 4 & 2 of 4)

LOC	DIST	REVISIONS					
		P	LTN	DESCRIPTION	DATE	DWN	APVD
A	66	-	-	SEE SHEET 1	-	-	-

-	1	1	2-1722335-1	THREAD BOLT GEWINDEBOLZEN	261
-	1	1	2119082-7	CAM, SNAIL, INSULATION ADJUSTMENT	244
-	1	1	2079764-1	WASHER, WAVE SPRING, CREST-TO-CREST	243
△	-	1	2119083-1	RETAINER, INSULATION DIAL	242
-	-	1	7-18023-7	SCR, SKT HD CAP M3 X 4.0	241
-	-	1	2119580-1	MECHANICAL FEED ASSEMBLY	239
-	1	-	2844940-1	AIR FEED MODULE	238
-	1	1	455053-2	PLATE, RETAINING	180
-	1	1	4-21028-0	PIN, SLOTTED SPRING .094 X .750	177
-	2	2	22278-9	SPRING, COMPRESSION	176
-	1	1	1803129-1	PLATE, RETAINER	175
-	REF	REF	994970-2	COUNTER, MAGNETIC	164
-	1	-	2119641-2	FEED CAM, AIR FEED	151
-	1	1	2168083-8	SCR, SKT HD CAP, RoHS, M4 X 16	144
-	4	4	2168083-9	SCR, SKT HD CAP, RoHS, M4 X 20	143
-	-	1	2119653-2	FEED CAM, POST FEED	142
-	1	1	1-1803583-0	APPLICATOR BASIC ASSEMBLY, SF	141
-	1	1	1803516-1	RAM ASSEMBLY, SF PACIFIC	140
-	1	1	1-22281-8	SPRING, COMPRESSION	121
-	1	1	1-18028-2	WASHER, FLAT, REG M4	119
-	1	1	2844908-1	SCREW, LOCKING	99
-	1	1	2844907-1	POST, LOCKING	98
-	1	1	1-690438-0	FRONT STRIP GUIDE	96
-	2	2	2168083-1	SCR, SKT HD CAP, RoHS, M3 X 8.0	95
-	1	1	2168083-6	SCR, SKT HD CAP, RoHS, M5 X 65	93
-	1	1	455888-5	SPACER, CRIMPER	82
-	1	1	1803607-3	DOCUMENTATION PACKAGE	71
-	1	1	2119791-9	DEPRESSOR, WIRE	70
-	1	1	2119740-1	TAG IDENTIFICATION	67
-	2	2	2168078-1	SCREW, DRIVE, RH, RoHS, 2 x .188	66
-	1	1	2-18032-5	SCR, SET, FLT PNT, M5 X 20.0	61
-	1	1	5-18022-5	SCR, HEX HD CAP, M4 X 6.0	59
-	1	1	1338685-1	PAWL, FEED	56
-	2	2	1-2168083-2	SCR, SKT HD CAP, RoHS, M4 X 25	53
-	1	1	18031-1	SCR, SET, CUP POINT M3 X 5.0	52
-	1	1	1424303-2	HOLDER, TERMINAL	51
-	1	1	455052-3	CARRIER, HOLD DOWN	50
-	1	2	18023-9	SCR, SKT HD CAP M4 X 6.0	49
-	-	1	2119652-1	FEED CAM, PRE FEED	48
-	1	1	1803602-1	SCR, BHSC, RoHS (M8 X 25)	41
-	1	1	5-1752356-5	SUPPORT, TERMINAL	34
-	2	2	2079383-5	SCR, BHSC, RoHS (M4 X 20)	33
-	2	2	2-2844962-4	SPACER, CYLINDRICAL, STRIP GUIDE	30
-	1	1	2844938-1	PLATE, STRIP GUIDE	29
-	2	2	22283-1	SPRING, COMPRESSION	27
-	1	1	356835-1	LEVER, DRAG RELEASE	26
-	1	1	1803142-1	DRAG, TERMINAL	25
-	1	1	1320928-2	STRIP GUIDE	24
-	1	1	980371-4	SCR, SKT HD SHLDR 5.0 DIA X 6.0	23
-	1	1	2168083-2	SCR, SKT HD CAP, RoHS, M4 X 8.0	21
-	1	1	1-18028-2	WASHER, FLAT, REG M4	20
-	1	1	2119533-3	STRIPPER, SIDE FEED	19
△	-	1	2119806-1	INSERT, SHEAR	13
-	1	1	3-22280-3	SPRING, COMPRESSION	12
-	1	1	1-356885-4	STOP, SHEAR	11
△	-	1	2119805-1	SHEAR HOLDER, FRONT	10
△	-	1	1633861-3	SHEAR, FLOATING	9
△	1	1	1-1633916-2	ANVIL, COMBINATION	8
-	1	1	240641-9	SPACER	7
-	-	-	-	-	6
-	1	1	2119757-8	DEPRESSOR, SHEAR	5
-	1	1	4-238011-1	BLOCK, CRIMPER SPACER	4
△	1	1	1633966-5	CRIMPER, INSULATION O	3
-	-	-	-	-	2
△	1	1	456401-3	CRIMPER, WIRE .042 F PREMIUM	1

DIMENSIONS:		TOLERANCES UNLESS OTHERWISE SPECIFIED:		APPLICATOR DATA	
mm	0 PLC ±	1 PLC ±	2 PLC ±	3 PLC ±	4 PLC ±
	ANGLES				
MATERIAL	FINISH	WEIGHT	SCALE	SHEET	REV
			1:2	3 OF 4	E

LOC		DIST		REVISIONS			
A	66	P	LTH	DESCRIPTION	DATE	OWN	APVD
		-		SEE SHEET 1			

FEED TYPE MECHANICAL

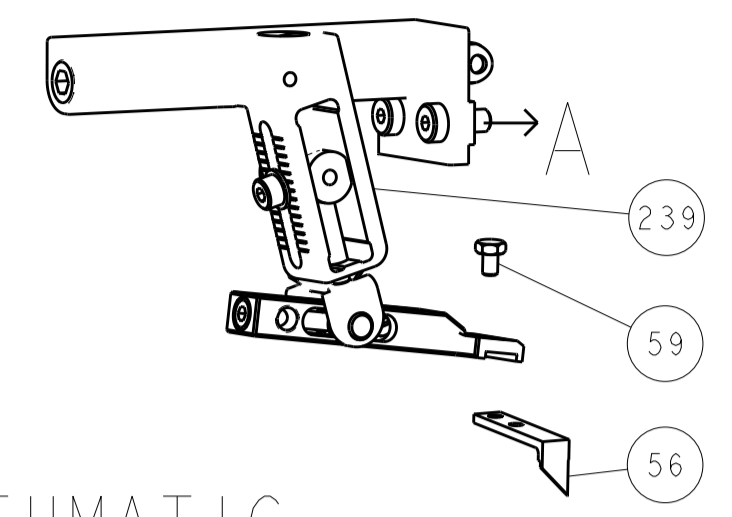

PNEUMATIC

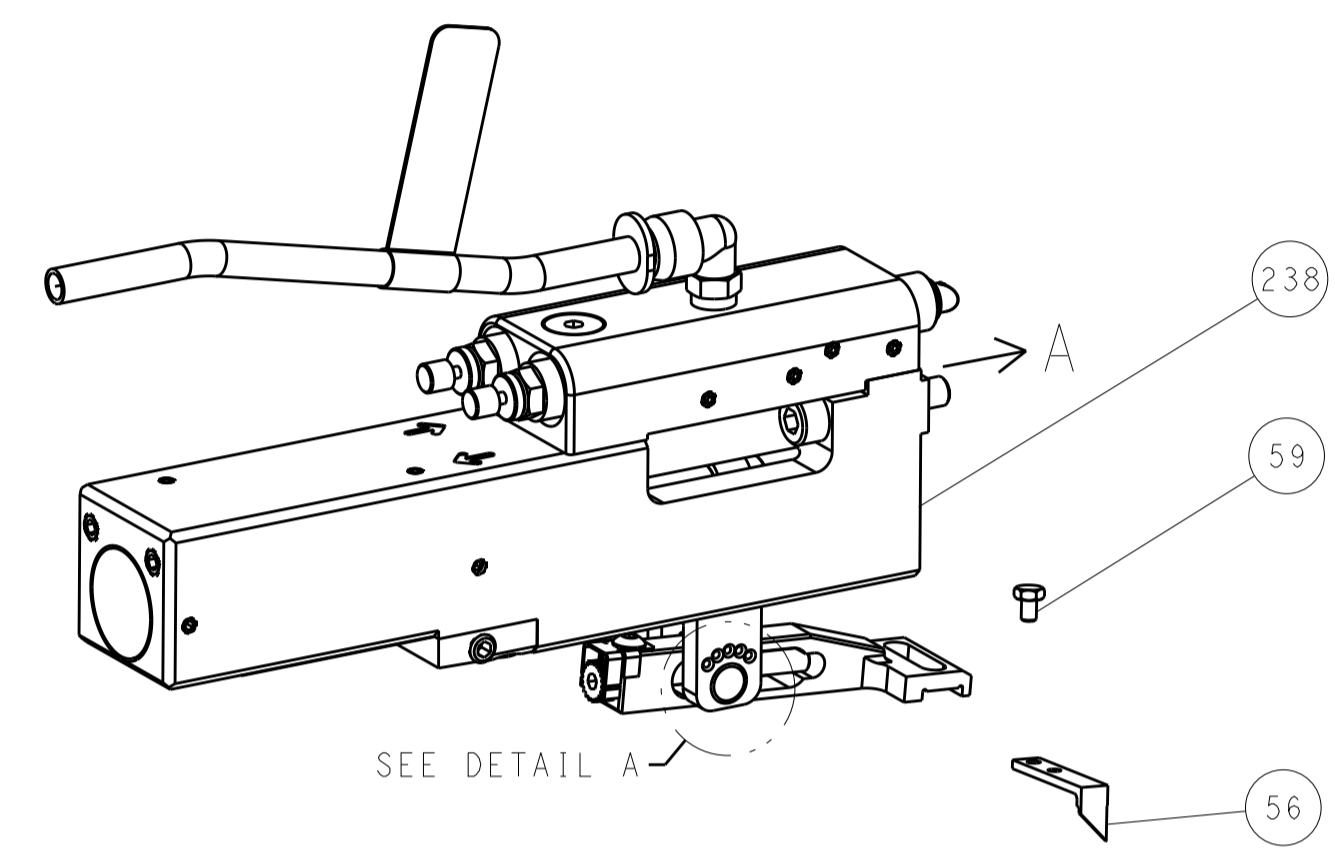

FEED SPRING SETTING POSITION (SHOWN FROM REAR SIDE)

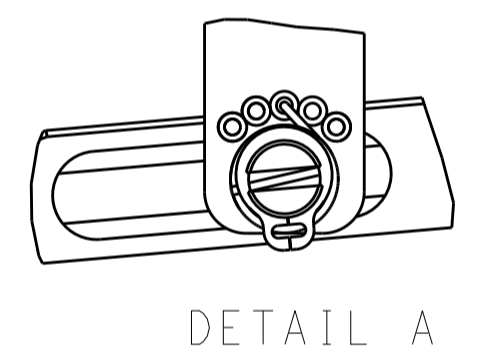

CAM POSITIONS

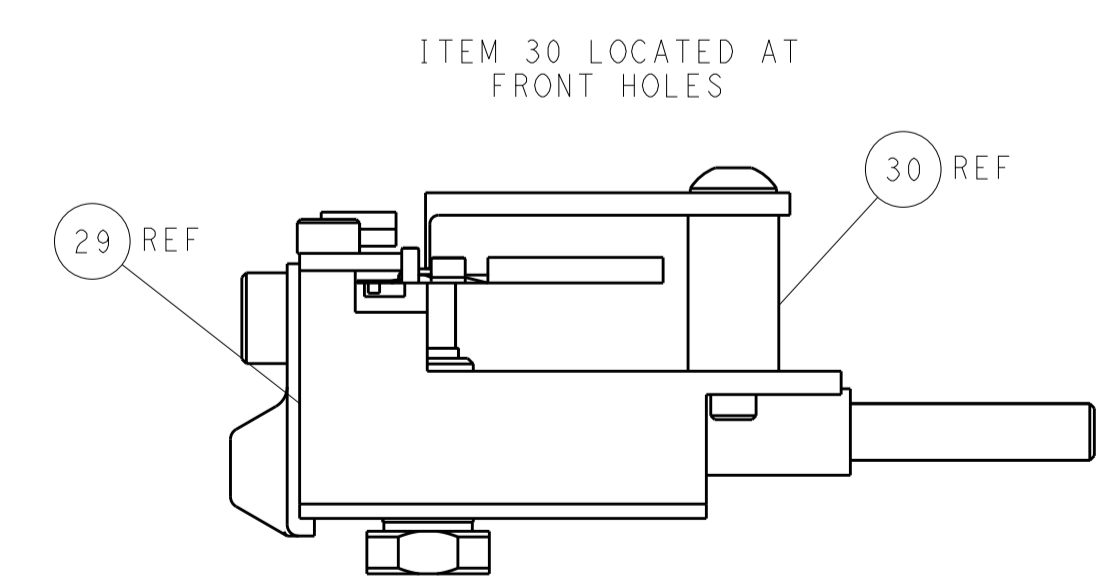
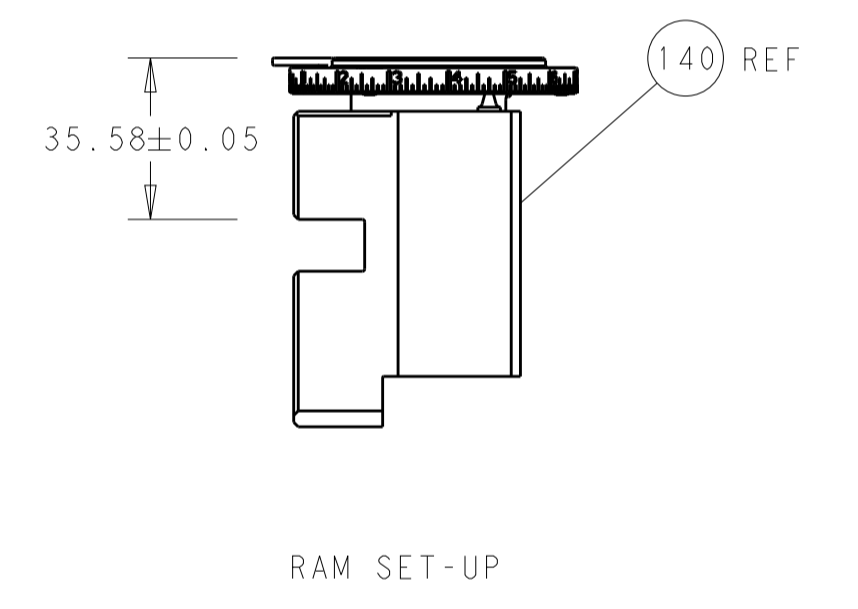
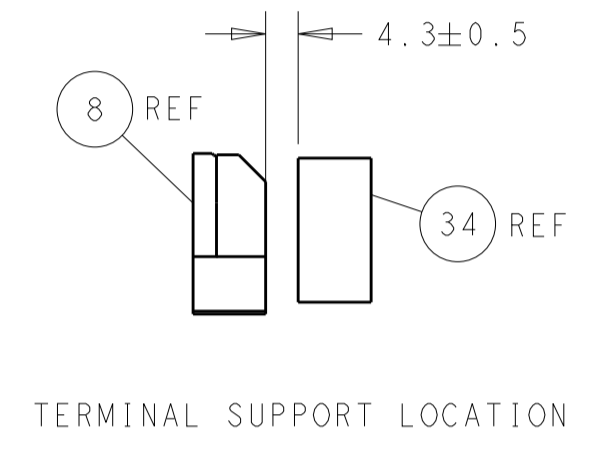
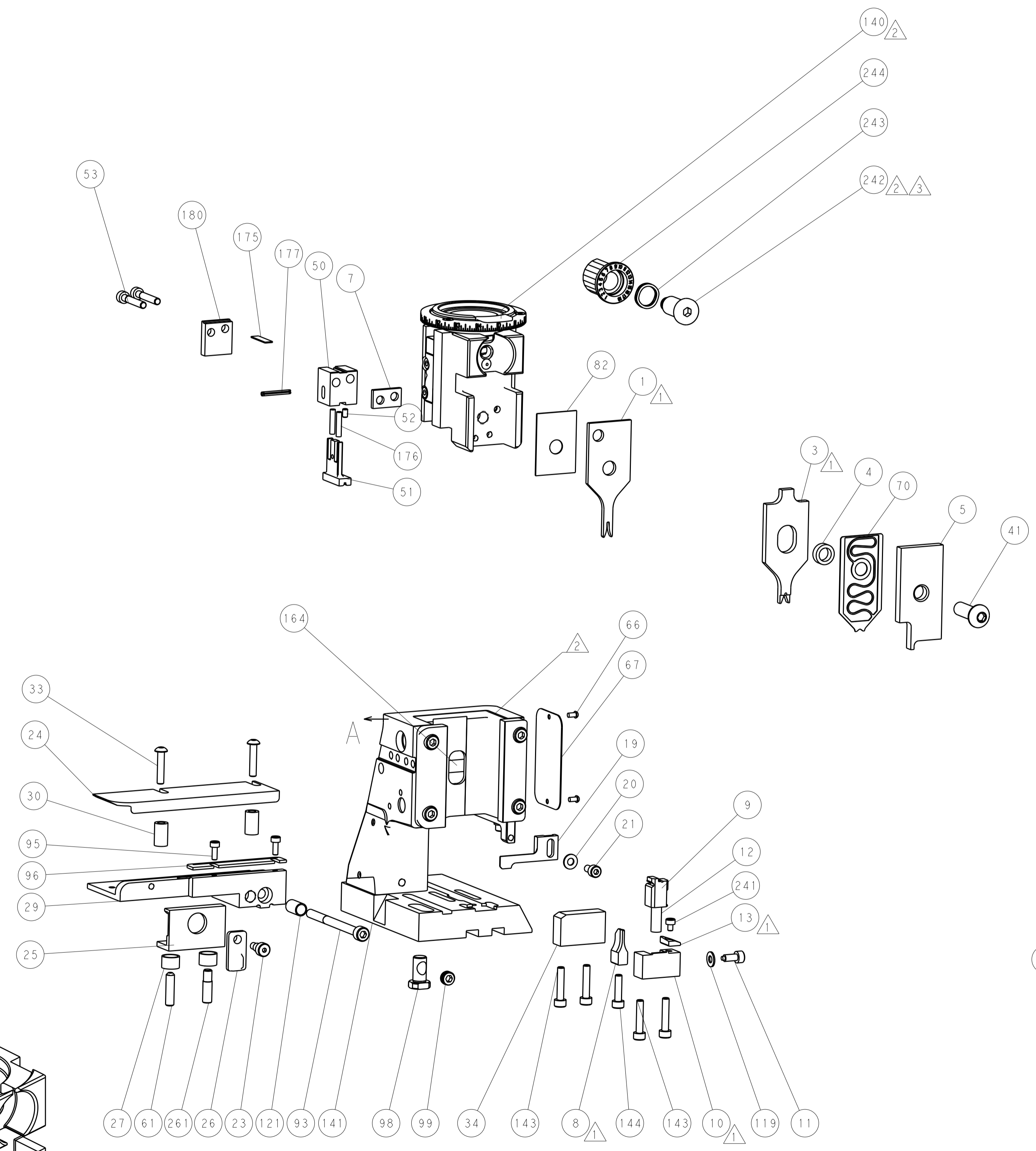
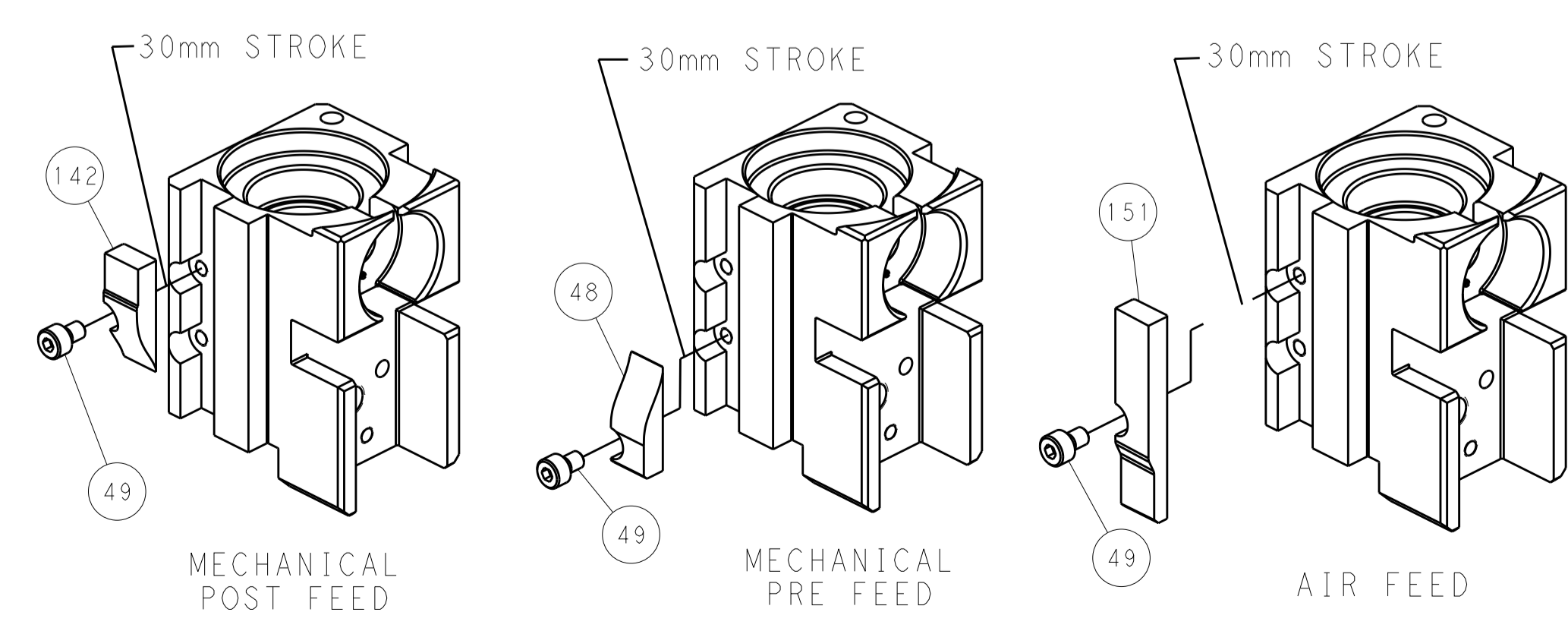

PACIFIC VERSION
 Shown on sheets 3 of 4 & 4 of 4
 (Atlantic version shown on sheets 1 of 4 & 2 of 4)

DIMENSIONS:		TOLERANCES UNLESS OTHERWISE SPECIFIED:		DWN C. MOYER 01JAN2012		TE Connectivity Harrisburg, PA 17105-3608	
mm	0 PLC	±		CHK T. ELBIN 01JAN2012	NAME	Ocean Side Feed Applicator	
	1 PLC	±		APVD T. ELBIN 01JAN2012	PRODUCT SPEC	SIZE	CAGE CODE DRAWING NO
	2 PLC	±			APPLICATION SPEC	A1	00779 C=2151678
	3 PLC	±			WEIGHT	SCALE	1:2
	4 PLC	±			Customer Accessible Production Drawing	SHEET	4 OF 4
MATERIAL	FINISH					REV	E