

Small Footprint Hi-Speed USB 2.0 Device PHY with UTMI Interface

PRODUCT FEATURES

Data Brief

- Available in a 40 ball lead-free RoHS compliant (4 x 4 x 0.9mm) VFBGA package
- Interface compliant with the UTMI specification (60MHz, 8-bit bidirectional interface)
- Only one required power supply (+3.3V)
- Supports 480Mbps Hi-Speed (HS) and 12Mbps Full Speed (FS) serial data transmission rates
- Integrated 45Ω and 1.5kΩ termination resistors reduce external component count
- Internal short circuit protection of DP and DM lines
- On-chip oscillator operates with low cost 24MHz crystal
- Latch-up performance exceeds 150mA per EIA/JESD 78, Class II
- ESD protection levels of 5kV HBM without external protection devices
- SYNC and EOP generation on transmit packets and detection on receive packets
- NRZI encoding and decoding
- Bit stuffing and unstuffing with error detection
- Supports the USB suspend state, HS detection, HS Chirp, Reset and Resume
- Support for all test modes defined in the USB 2.0 specification
- 55mA Unconfigured Current (typical) - ideal for bus powered applications.
- 83uA suspend current (typical) - ideal for battery powered applications.
- Industrial Operating Temperature -40°C to +85°C

Applications

The USB3290 is the ideal companion to any ASIC, SoC or FPGA solution designed with a UTMI Hi-Speed USB device (peripheral) core.

The USB3290 is well suited for:

- Cell Phones
- MP3 Players
- Scanners
- External Hard Drives
- Digital Still and Video Cameras
- Portable Media Players
- Entertainment Devices
- Printers



ORDER NUMBER(S):

USB3290-FH FOR 40 BALL, VFBGA LEAD-FREE ROHS COMPLIANT PACKAGE

USB3290-FH-TR FOR 40 BALL, VFBGA LEAD-FREE ROHS COMPLIANT PACKAGE (TAPE AND REEL)

Reel Size is 4000 pieces.



80 ARKAY DRIVE, HAUPPAUGE, NY 11788 (631) 435-6000, FAX (631) 273-3123

Copyright © 2007 SMSC or its subsidiaries. All rights reserved.

Circuit diagrams and other information relating to SMSC products are included as a means of illustrating typical applications. Consequently, complete information sufficient for construction purposes is not necessarily given. Although the information has been checked and is believed to be accurate, no responsibility is assumed for inaccuracies. SMSC reserves the right to make changes to specifications and product descriptions at any time without notice. Contact your local SMSC sales office to obtain the latest specifications before placing your product order. The provision of this information does not convey to the purchaser of the described semiconductor devices any licenses under any patent rights or other intellectual property rights of SMSC or others. All sales are expressly conditional on your agreement to the terms and conditions of the most recently dated version of SMSC's standard Terms of Sale Agreement dated before the date of your order (the "Terms of Sale Agreement"). The product may contain design defects or errors known as anomalies which may cause the product's functions to deviate from published specifications. Anomaly sheets are available upon request. SMSC products are not designed, intended, authorized or warranted for use in any life support or other application where product failure could cause or contribute to personal injury or severe property damage. Any and all such uses without prior written approval of an Officer of SMSC and further testing and/or modification will be fully at the risk of the customer. Copies of this document or other SMSC literature, as well as the Terms of Sale Agreement, may be obtained by visiting SMSC's website at <http://www.smisc.com>. SMSC is a registered trademark of Standard Microsystems Corporation ("SMSC"). Product names and company names are the trademarks of their respective holders.

SMSC DISCLAIMS AND EXCLUDES ANY AND ALL WARRANTIES, INCLUDING WITHOUT LIMITATION ANY AND ALL IMPLIED WARRANTIES OF MERCHANTABILITY, FITNESS FOR A PARTICULAR PURPOSE, TITLE, AND AGAINST INFRINGEMENT AND THE LIKE, AND ANY AND ALL WARRANTIES ARISING FROM ANY COURSE OF DEALING OR USAGE OF TRADE. IN NO EVENT SHALL SMSC BE LIABLE FOR ANY DIRECT, INCIDENTAL, INDIRECT, SPECIAL, PUNITIVE, OR CONSEQUENTIAL DAMAGES; OR FOR LOST DATA, PROFITS, SAVINGS OR REVENUES OF ANY KIND; REGARDLESS OF THE FORM OF ACTION, WHETHER BASED ON CONTRACT; TORT; NEGLIGENCE OF SMSC OR OTHERS; STRICT LIABILITY; BREACH OF WARRANTY; OR OTHERWISE; WHETHER OR NOT ANY REMEDY OF BUYER IS HELD TO HAVE FAILED OF ITS ESSENTIAL PURPOSE, AND WHETHER OR NOT SMSC HAS BEEN ADVISED OF THE POSSIBILITY OF SUCH DAMAGES.



General Description

The USB3290 provides the Physical Layer (PHY) interface to a USB 2.0 Device Controller. The IC is available in a 40 ball lead-free RoHS compliant VFBGA package. The small footprint package makes the USB3290 ideal for portable consumer electronics applications.

The USB3290 is an industrial temperature USB 2.0 physical layer transceiver (PHY) integrated circuit. SMSC's proprietary technology results in low power dissipation, which is ideal for building a bus powered USB 2.0 peripheral. The PHY uses an 8-bit bidirectional parallel interface, which complies with the USB Transceiver Macrocell Interface (UTMI) specification. It supports 480Mbps transfer rate, while remaining backward compatible with USB 1.1 legacy protocol at 12Mbps.

All required termination and 5.25V short circuit protection of the DP/DM lines are internal to the chip. The USB3290 also has an integrated 1.8V regulator so that only a 3.3V supply is required.

While transmitting data, the PHY serializes data and generates SYNC and EOP fields. It also performs needed bit stuffing and NRZI encoding. Likewise, while receiving data, the PHY de-serializes incoming data, stripping SYNC and EOP fields and performs bit un-stuffing and NRZI decoding.

Block Diagram

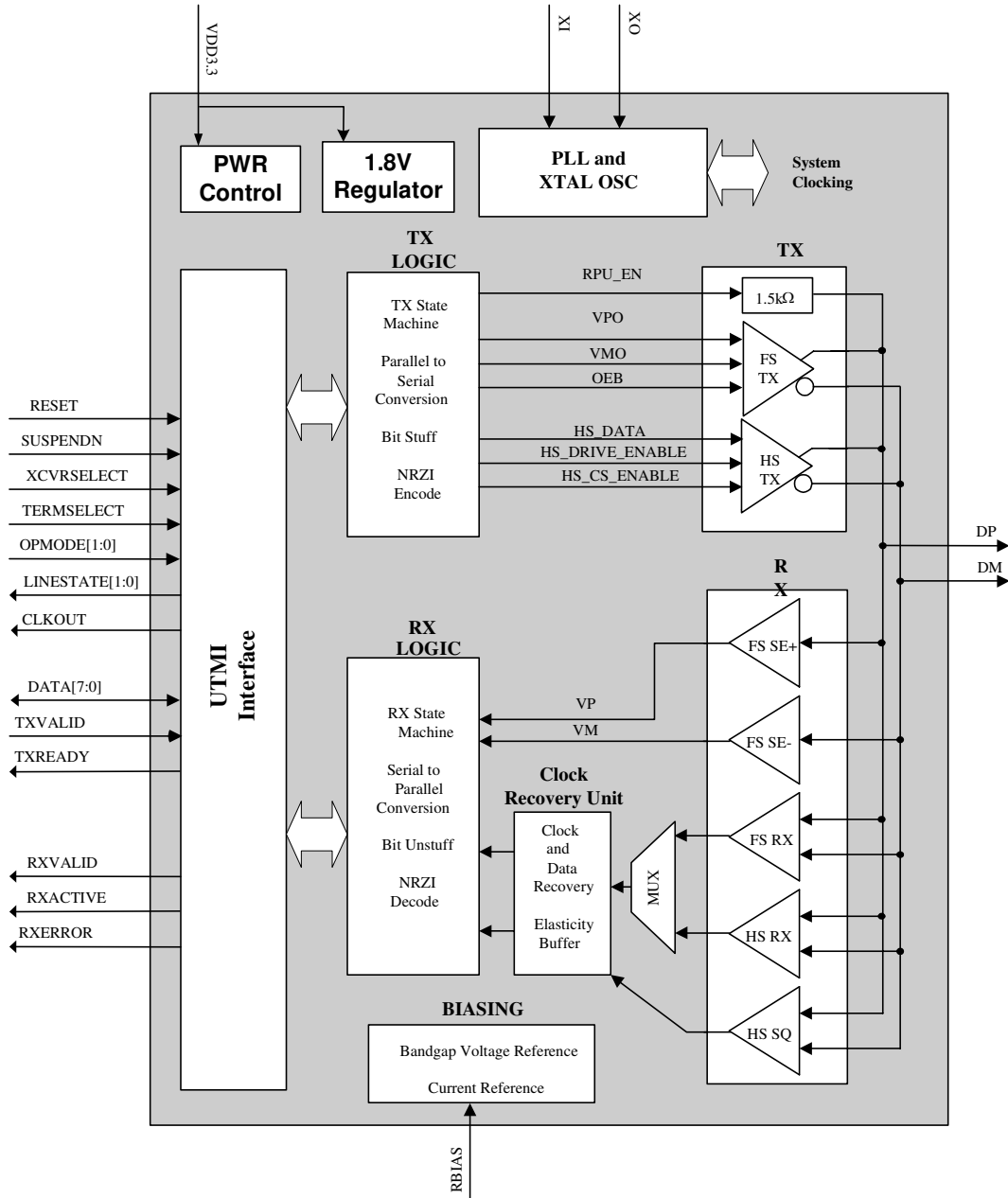

Figure 1 USB3290 Block Diagram

Package Outline

Revision 1.5 (11-02-07)

PRODUCT PREVIEW

SMSC USB3290

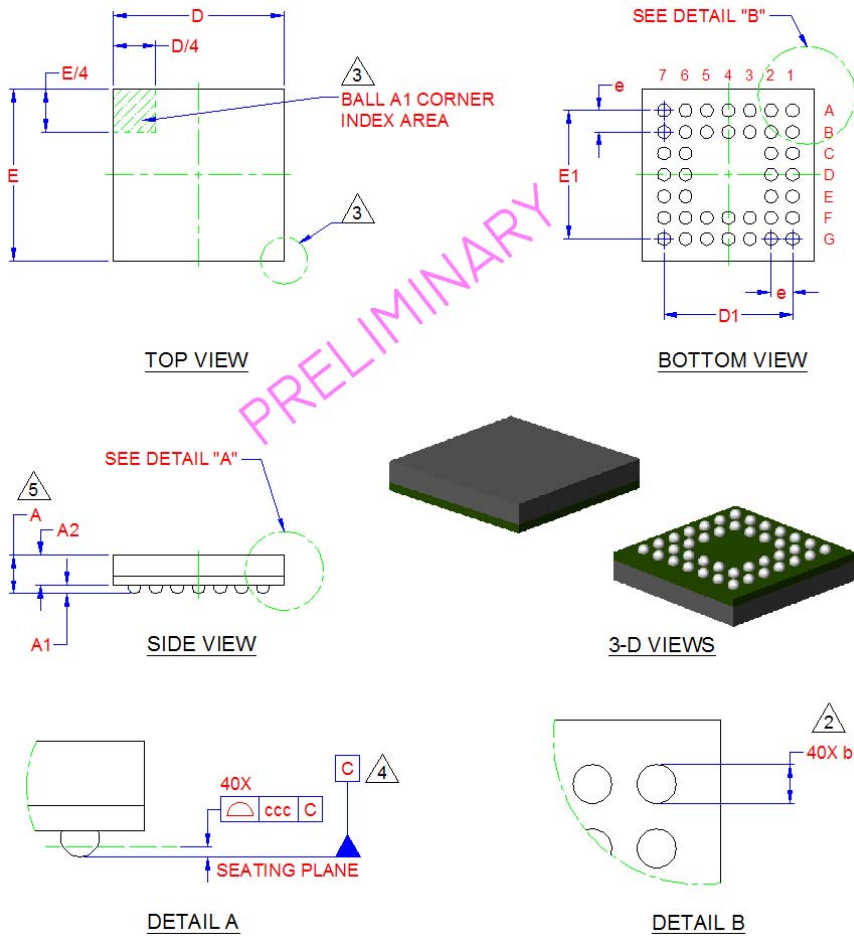

PRELIMINARY

COMMON DIMENSIONS					
SYMBOL	MIN	NOM	MAX	NOTE	REMARK
A	-	-	1.00	5	OVERALL PACKAGE HEIGHT
A1	0.15	-	-	-	STANDOFF
A2	0.65	-	-	-	PKG BODY THICKNESS
D/E	3.90	4.00	4.10	-	X/Y BODY SIZE
D1/E1	3.00 BSC		-	-	X/Y END BALLS DISTANCE
b	0.25	0.30	0.35	2	BALL DIAMETER
e	0.50 BSC		-	-	BALL PITCH
ccc	0	-	0.08	4	COPLANARITY

- NOTES:**
- ALL DIMENSIONS ARE IN MILLIMETERS.
 - MAXIMUM RADIAL TRUE POSITION TOLERANCE OF EACH BALL IS $\pm 0.075\text{mm}$ AT MAXIMUM MATERIAL CONDITION. DIMENSION "b" IS MEASURED AT THE MAXIMUM BALL DIAMETER, PARALLEL TO PRIMARY DATUM "C".
 - THE BALL "A1" CORNER MUST BE IDENTIFIED IN THE INDICATED AREA OF THE TOP PACKAGE SURFACE BY USING A CORNER CHAMFER, INK/LASER/METALIZED MARKING, INDENTATION, OR OTHER FEATURE OF PACKAGE BODY. EXACT SHAPE OF EACH CORNER IS OPTIONAL, BUT TERMINAL "A1" CORNER MUST BE UNIQUE.
 - PRIMARY DATUM "C" AND SEATING PLANE ARE DEFINED BY THE SPHERICAL CROWNS OF THE CONTACT SOLDER BALLS.
 - DIMENSION "A" DOES NOT INCLUDE ATTACHED EXTERNAL FEATURES, SUCH AS HEAT SINK OR CHIP CAPACITORS.

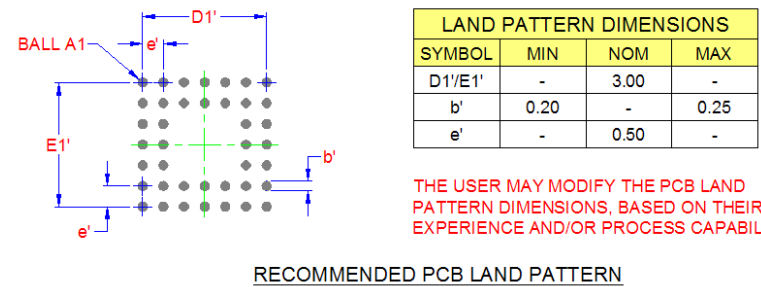

Figure 2 USB3290-FH 40 Ball, VFBGA Package Outline & Parameters 4x4x0.9mm Body, Lead-Free RoHS Compliant