

MOD-RS485-ISO

Isolated extension board with RS485 interface

USER'S MANUAL

Document revision C, April 2017

Designed by OLIMEX Ltd, 2017



All boards produced by Olimex LTD are ROHS compliant

DISCLAIMER

© 2017 Olimex Ltd. Olimex®, logo and combinations thereof, are registered trademarks of Olimex Ltd. Other product names may be trademarks of others and the rights belong to their respective owners.

The information in this document is provided in connection with Olimex products. No license, express or implied or otherwise, to any intellectual property right is granted by this document or in connection with the sale of Olimex products.

The Hardware project is released under the Creative Commons Attribution-Share Alike 3.0 United States License. You may reproduce it for both your own personal use, and for commercial use. You will have to provide a link to the original creator of the project <http://www.olimex.com> on any documentation or website. You may also modify the files, but you must then release them as well under the same terms. Credit can be attributed through a link to the creator website: <http://www.olimex.com>

The software is released under GPL.

It is possible that the pictures in this manual differ from the latest revision of the board.

The product described in this document is subject to continuous development and improvements. All particulars of the product and its use contained in this document are given by OLIMEX in good faith. However all warranties implied or expressed including but not limited to implied warranties of merchantability or fitness for purpose are excluded. This document is intended only to assist the reader in the use of the product. OLIMEX Ltd. shall not be liable for any loss or damage arising from the use of any information in this document or any error or omission in such information or any incorrect use of the product.

This evaluation board/kit is intended for use for engineering development, demonstration, or evaluation purposes only and is not considered by OLIMEX to be a finished end-product fit for general consumer use. Persons handling the product must have electronics training and observe good engineering practice standards. As such, the goods being provided are not intended to be complete in terms of required design-, marketing-, and/or manufacturing-related protective considerations, including product safety and environmental measures typically found in end products that incorporate such semiconductor components or circuit boards.

Olimex currently deals with a variety of customers for products, and therefore our arrangement with the user is not exclusive. Olimex assumes no liability for applications assistance, customer product design, software performance, or infringement of patents or services described herein.

THERE IS NO WARRANTY FOR THE DESIGN MATERIALS AND THE COMPONENTS USED TO CREATE MOD-RS485-ISO. THEY ARE CONSIDERED SUITABLE ONLY FOR MOD-RS485-ISO.

Table of Contents

DISCLAIMER.....	2
CHAPTER 1: OVERVIEW.....	5
1. Introduction to the chapter.....	5
1.1 Features.....	5
1.2 Target market and purpose of the board.....	5
1.3 Board variants.....	5
1.4 Organization.....	6
CHAPTER 2: SETTING UP THE MOD-RS485-ISO BOARD.....	7
2. Introduction to the chapter.....	7
2.1 Electrostatic warning.....	7
2.2 Requirements.....	7
2.3 Powering the board.....	7
CHAPTER 3: MOD-RS485-ISO BOARD DESCRIPTION.....	8
3. Introduction to the chapter.....	8
3.1 Layout (top view).....	8
CHAPTER 4: THE ISOT35 TRANSCEIVER AND THE PIC16.....	9
4. Introduction to the chapter.....	9
4.1 The ISOT35.....	9
4.2 The microcontroller.....	10
4.3 The firmware.....	10
CHAPTER 5: CONTROL CIRCUITY.....	11
5. Introduction to the chapter.....	11
5.1 Reset.....	11
5.2 Clocks.....	11
5.3 Power supply circuit.....	11
CHAPTER 6: CONNECTORS AND PINOUT.....	12
6. Introduction to the chapter.....	12
6.1 UEXT module.....	12
6.2 X1 and X2 RS485 connectors.....	13
6.3 ICSP connector.....	13
6.4 Jumper description.....	14
6.4.1 PROG.....	14
6.4.2 Z-B, Y-A.....	14
6.5 Additional hardware components.....	14
CHAPTER 7: SCHEMATICS.....	15
7. Introduction to the chapter.....	15
7.1 Eagle schematic.....	15

7.2 Physical dimensions.....17

CHAPTER 8: REVISION HISTORY AND SUPPORT.....18

8. Introduction to the chapter.....18

8.1 Document revision.....18

8.2 Board revision.....18

8.3 Useful web links and purchase codes.....19

8.4 Product support.....20

CHAPTER 1: OVERVIEW

1. Introduction to the chapter

Thank you for choosing the MOD-RS485-ISO – optically isolated RS485 interface from Olimex! This document provides a user's guide for the MOD-RS485-ISO extension board. As an overview, this chapter gives the scope of this document and lists the board's features. The document's organization is then detailed.

Using MOD-RS485-ISO you can easily interface our development boards with UEXT on one side and industrial networks with RS485 interface, metering instruments etc, on the other,

1.1 Features

- ISO35T converter from Texas Instruments
- UEXT connector with UEXT cable in package
- RS485 connector full duplex, convertible to half duplex via PTH jumpers
- ICSP connector for reprogramming the firmware
- FR-4, 1.5 mm, soldermask, component print
- Dimensions: (58 x 30)mm ~ (2.3 x 1.2)"

1.2 Target market and purpose of the board

The board is a good solution for people who already have an Olimex board, but need to communicate with their target using RS485/RS422 interface. Due to its compact size, price and the 3kV isolation MOD-RS485 is a very solid choice when used in harsh environment.

1.3 Board variants

MOD-RS485 – unlike MOD-RS485-ISO it is only half-duplex; no galvanic isolation; no custom firmware; no ICSP for easier programming; different chip than the ISO version; of course, it costs less.

1.4 Organization

Each section in this document covers a separate topic, organized as follow:

- Chapter 1 is an overview of the board usage and features
- Chapter 2 provides a guide for quickly setting up the board and software notes
- Chapter 3 contains the general board diagram and layout
- Chapter 4 describes the components that are the heart of the board: the ISOT35 transceiver and the PIC16 chip
- Chapter 5 is an explanation of the control circuitry associated with the microcontroller to reset. Also shows the clocks on the board
- Chapter 6 covers the connector pinout, peripherals and jumper description
- Chapter 7 provides the schematics
- Chapter 8 contains the revision history, useful links and support information

CHAPTER 2: SETTING UP THE MOD-RS485-ISO BOARD

2. Introduction to the chapter

This section helps you set up the MOD-RS485-ISO development board for the first time. Please consider first the electrostatic warning to avoid damaging the board, then discover the hardware and software required to operate the board.

The procedure to power up the board is given, and a description of the default board behavior is detailed.

2.1 Electrostatic warning

MOD-RS485-ISO is shipped in a protective anti-static package. The board must not be exposed to high electrostatic potentials. A grounding strap or similar protective device should be worn when handling the board. Avoid touching the component pins or any other metallic element.

2.2 Requirements

In order to set up the MOD-RS485-ISO optimally, the following items are required:

- Olimex host board with UEXT connector(advisably a PIC one since you can program both with 1 programmer).

2.3 Powering the board

The board can be powered either via the UEXT or via the ICSP. Check the software section of the web-page of the board for code examples.

CHAPTER 3: MOD-RS485-ISO BOARD DESCRIPTION

3. Introduction to the chapter

Here you get acquainted with the main parts of the board. Note the names used on the board might differ from the names used below to describe them. For the actual names check the MOD-RS485-ISO board itself.

3.1 Layout (top view)

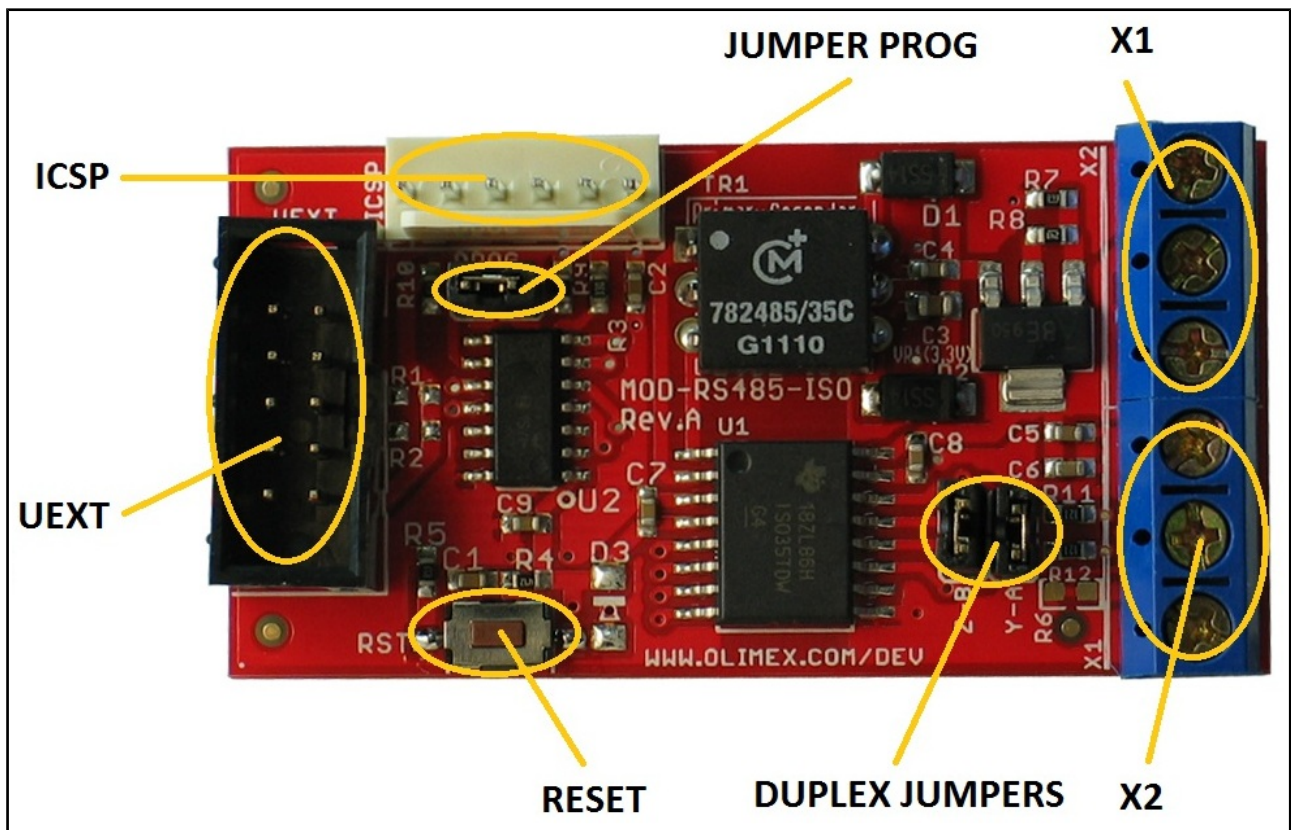

The picture above shows the initial revision of MOD-RS485-ISO. The latest revision features different PIC16 chip.

CHAPTER 4: THE ISOT35 TRANSCEIVER AND THE PIC16

4. Introduction to the chapter

In this chapter is located the information about the heart of MOD-RS485-ISO – the Texas Instruments. The information is a modified version of the datasheet provided by its manufacturers.

4.1 The ISOT35

The ISO35T is an isolated differential line transceiver with integrated oscillator outputs that provide the primary voltage for an isolation transformer. The device is a full-duplex differential line transceiver for RS-485 and RS-422 applications that can easily be configured for half-duplex operation by connecting pin 11 to pin 14, and pin 12 to pin 13.

- 3000VRMS / 4242V_{PK} Isolation
- Bus-Pin ESD Protection
 - 16 kV HBM Between Bus-Pins and GND2
 - 6 kV HBM Between Bus-Pins and GND1
- 1/8 Unit Load – Up to 256 Nodes on a Bus
- Designed for RS-485 and RS-422 Applications
- Signaling Rates up to 1 Mbps
- Thermal Shutdown Protection
- Typical Efficiency > 60% (I_{LOAD} = 100 mA)
- Low Driver Bus Capacitance 16 pF (Typ)
- 50 kV/ μ s Typical Transient Immunity
- UL 1577, IEC 60747-5-2 (VDE 0884, Rev. 2)
- Fail-safe Receiver for Bus Open, Short, Idle
- Logic Inputs are 5-V Tolerant

It is strongly recommended to check the chip's web page at the following web-address: <http://www.ti.com/lit/ds/symlink/iso35t.pdf> for electrical characteristics.

4.2 The microcontroller

The board has a PIC16 microcontroller that contains custom firmware. The idea is to be able to use the features of the board faster without writing own software. The firmware is described in the next sub-chapter.

Note that the original design of MOD-RS485-ISO used PIC16F1503 which was replaced by the PIC16F18324 in hardware revision C. The more powerful PIC16F18324 allowed to upgrade the firmware (it has remappable pins, higher clock frequency among other advantages). The main chip controls the input signals for the board and leads them to the transceiver.

The datasheet of PIC16F18324 might be found here:

<http://ww1.microchip.com/downloads/en/devicedoc/40001800a.pdf>

Note that the first release of MOD-RS485 used PIC16F1503. More info about Microchip's PIC16F1503 can be found here: <http://ww1.microchip.com/downloads/en/DeviceDoc/41607A.pdf>

4.3 The firmware

The board comes with custom firmware which allows the module to convert RS232 or I2C to RS485/RS422 with few commands.

Refer to the wiki article of the board on details about the address map of different functions:

<https://www.olimex.com/wiki/MOD-RS485-ISO>

Refer to the Arduino library for example software implementation:

<https://github.com/OLIMEX/MOD-RS485-ISO>

CHAPTER 5: CONTROL CIRCUITY

5. Introduction to the chapter

Here you can find information about reset circuit and quartz crystals locations, the power supply circuit is discussed.

5.1 Reset

The reset line includes R4 (4.7k), C1 (4.7 nF), R5 (390R), reset button and processor pin 4(#MCLR).

5.2 Clocks

There is no quartz crystal mounted on the board.

5.3 Power supply circuit

The board is powered either by pin 2 of the ICSP connector or pin 1 of the UEXT connector.

CHAPTER 6: CONNECTORS AND PINOUT

6. Introduction to the chapter

In this chapter are presented the connectors that can be found on the board all together with their pinout and notes about them. Jumpers functions are described. Notes and info on specific peripherals are presented. Notes regarding the interfaces are given.

6.1 UEXT module

MOD-RS485-ISO board has UEXT connector and can interface Olimex's UEXT modules. The signals for this board are set in DEVICE mode. Without modification it can connect directly to board's which UEXT is set in HOST mode.

For more information on UEXT please visit:

<https://www.olimex.com/Products/Modules/UEXT/resources/UEXT.pdf>

UEXT connector		
Pin #	Signal Name	Processor Pin #
1	3.3V	-
2	GND	-
3	TXD	2
4	RXD	10
5	SCL	11
6	SDA	3
7	Not connected	-
8	Not connected	-
9	Not connected	-
10	Not connected	-

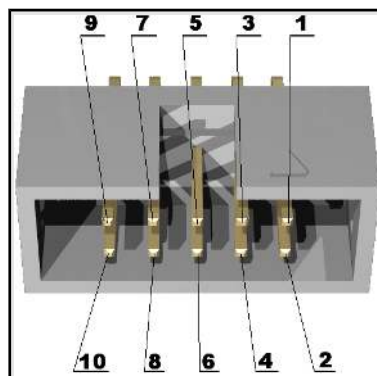

6.2 X1 and X2 RS485 connectors

These are the connectors forming the RS485/RS422 communication mean. Switching the jumpers can define the protocol to either HALF or FULL DUPLEX mode. The default mode is HALF DUPLEX mode. Please notice that the signal names of X1 and X2 can be found printed on the bottom of the board under the blue connectors (picture of those below).

X1 and X2 connectors		
Pin #	Signal Name	Processor Pin #
1-1	GND	-
1-2	Y	11
1-3	Z	12
2-1	B	13
2-2	A	14
2-3	3.3V	-



6.3 ICSP connector

Used for programming the PIC chip with a programmer. The step of the connector is 2.54mm (the bigger one).

ICSP connector		
Pin #	Signal Name	Processor Pin #
1	RESET	4
2	3.3V	-
3	GND	-
4	ICSPDAT	13
5	ICSPCLK	12
6	Not connected	-

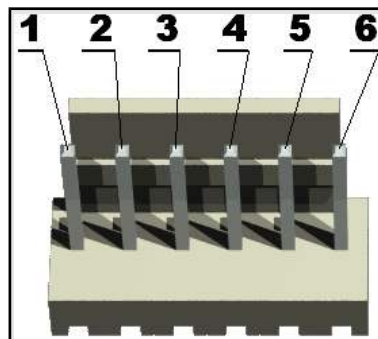

6.4 Jumper description

Please note that all the jumpers on the board are PTH type. For easier access use pincers.

6.4.1 PROG

The PROG jumper controls the I2C address given. If closed it will receive new I2C address. If open the board will not receive I2C address. Check the available examples and the text files in them for further info.

The default position is closed.

6.4.2 Z-B, Y-A

These jumpers must be moved together. When both are closed ISOT35's pin 11 and 14 are connected and also pins 12 and 13 are connected – which means the module is in HALF-DUPLEX mode. To enter FULL-DUPLEX mode – disconnect both jumpers.

The default positions are closed.

6.5 Additional hardware components

The components below are mounted on MOD-RS485-ISO but are not discussed above. They are listed here for completeness:

Reset button – used to reset the board

CHAPTER 7: SCHEMATICS

7. Introduction to the chapter

In this chapter are located the schematics describing logically and physically MOD-RS485-ISO.

7.1 Eagle schematic

MOD-RS485-ISO schematic is visible only for reference here. You can also find it on the MOD-RS485-ISO's page: <https://www.olimex.com/Products/Modules/Interface/MOD-RS485-ISO/resources/MOD-RS485-ISO-latest-schematic.pdf>

The EAGLE schematic is situated on the next page for quicker reference.

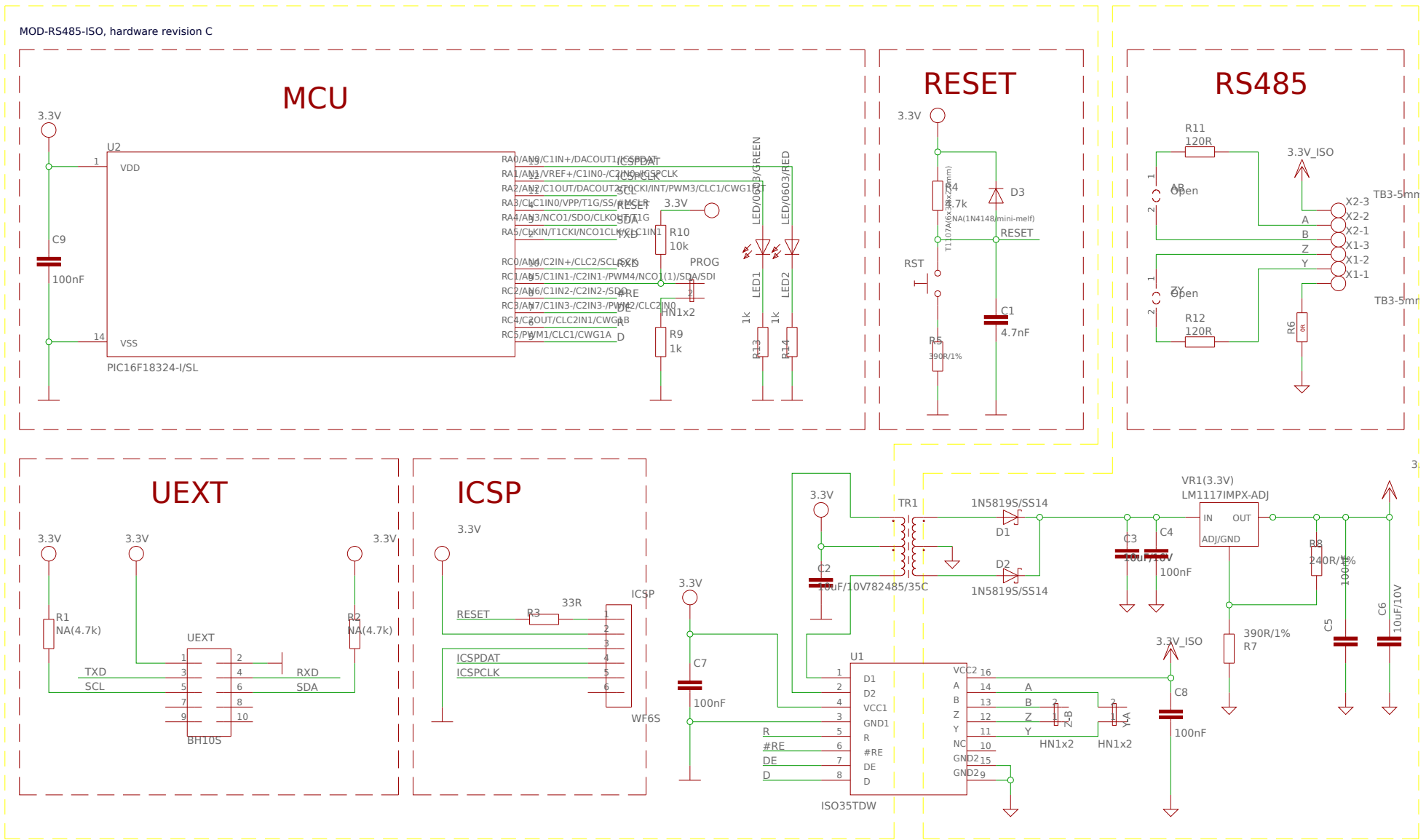

7.2 Physical dimensions

Note that all dimensions are in mils.

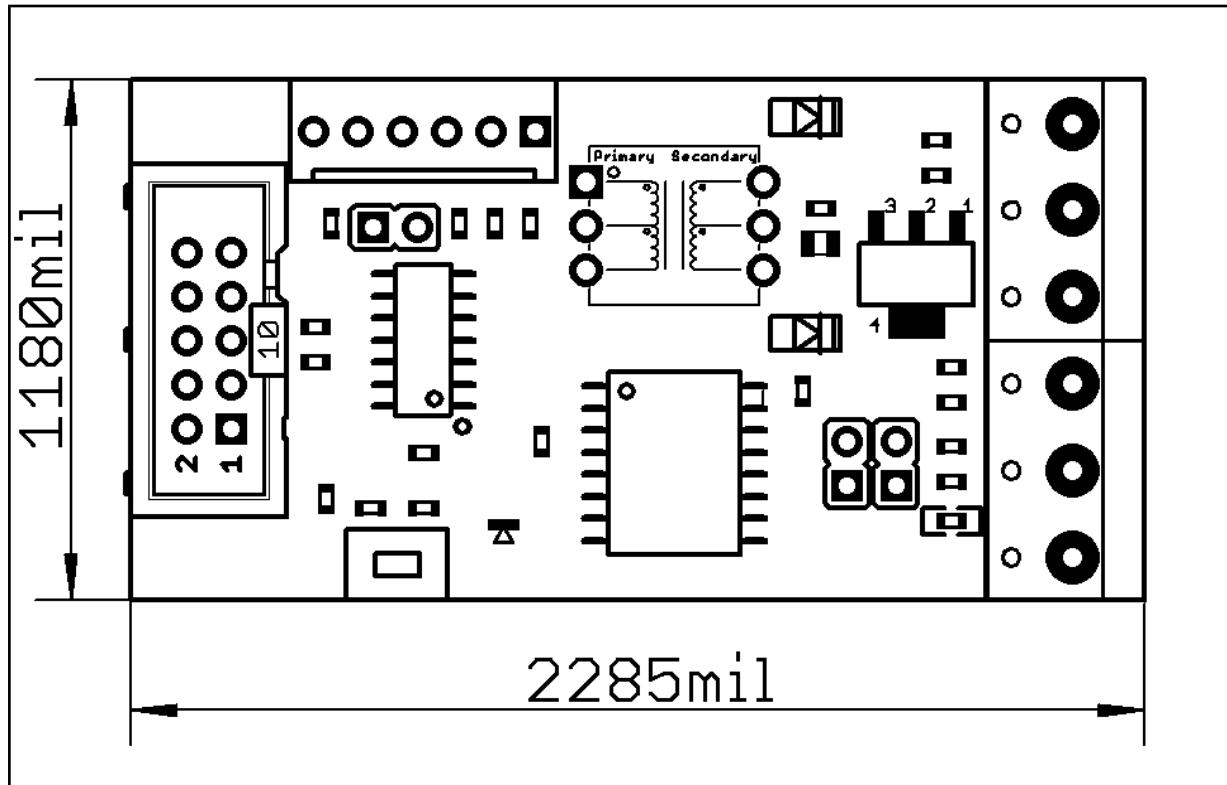

The three highest elements on the board in order from the tallest to the shortest are: ICSP connector – 450mils, RS485 connector – 400mils, UEXT connector – 350mils.

CHAPTER 8: REVISION HISTORY AND SUPPORT

8. Introduction to the chapter

In this chapter you will find the current and the previous version of the document you are reading. Also the web-page for your device is listed. Be sure to check it after a purchase for the latest available updates and examples.

8.1 Document revision

Revision	Changes	Modified Page#
A, 20.09.12	Initial Creation	All
B, 05.10.12	Various spelling errors and discrepancies fixed	Various
C, 27.04.17	Updated document for latest hardware revision (C)	Various

8.2 Board revision

Remember to check the schematics and the board design files to compare the differences.

Revision	Notable Changes
B	Initial release of the board
C	Changed microcontroller from PIC16F1503 to PIC16F18324; added LEDs on the ICSP data line and ICSP clock line

8.3 Useful web links and purchase codes

The web page you can visit for more info on your device is

<https://www.olimex.com/Products/Modules/Interface/MOD-RS485-ISO/>.

A place for general questions, FAQ or friendly talk check our forums:

<https://www.olimex.com/forum/>.

Instruction for software usage can be found at the wiki article here:

<https://www.olimex.com/wiki/MOD-RS485-ISO>

ORDER CODES:

MOD-RS485-ISO – the product subject in this manual

How to order?

You can purchase directly from our online shop or via any of our distributors.

Check <http://www.olimex.com/> for more info.

8.4 Product support

For product support, hardware information and error reports mail to: support@olimex.com. Note that we are primarily a hardware company and our software support is limited.

Please consider reading the paragraph below about the warranty of Olimex products.

Warranty and returns:

Our boards have lifetime warranty against manufacturing defects and components.

During development work it is not unlikely that you can burn your programmer or development board. This is normal, we also do development work and we have damaged A LOT of programmers and boards during our daily job so we know how it works. If our board/programmer has worked fine then stopped, please check if you didn't apply over voltage by mistake, or shorted something in your target board where the programmer was connected etc. Sometimes boards might get damaged by ESD shock voltage or if you spill coffee on them during your work when they are powered.

Please note that warranty do not cover problems caused by improper use, shorts, over-voltages, ESD shock etc.

If the board has warranty label it should be not broken. Broken labels void the warranty, same applies for boards modified by the customer, for instance soldering additional components or removing components – such boards will be not be a subject of our warranty.

If you are positive that the problem is due to manufacturing defect or component you can return the board back to us for inspection.

When we receive the board we will check and if the problem is caused due to our fault and we will repair/replace the faulty hardware free of charge, otherwise we can quote price of the repair.

Note that all shipping back and forth have to be covered by the customer. Before you ship anything back you need to ask for RMA. When you ship back please attach to it your shipping address, phone, e-mail, RMA# and brief description of the problem. All boards should be sent back in antistatic package and well packed to prevent damages during the transport.