

Quad PLL Programmable Clock Generator with Spread Spectrum

Features

- Four fully integrated phase-locked loops (PLLs)
 - Input frequency range
 - External crystal: 8 to 48 MHz
 - External reference: 8 to 166 MHz clock
 - Wide operating output frequency range
 - 3 to 166 MHz
 - Programmable spread spectrum with center and down spread option and lexmark and linear modulation profiles
 - Selectable V_{DD} supply voltage options:
 - 2.5 V, 3.0 V, and 3.3 V
 - Selectable output clock voltages, independent of V_{DD} supply:
 - 2.5 V, 3.0 V, and 3.3 V
 - Frequency select feature with option to select eight different frequencies over nine clock outputs
 - Output enable, and SS ON/OFF controls
 - Low jitter, high accuracy outputs
 - Ability to synthesize nonstandard frequencies with Fractional-N capability
 - Up to nine clock outputs with programmable drive strength
 - Glitch-free outputs while frequency switching
 - 20-pin TSSOP package

- Commercial and Industrial temperature ranges

Benefits

- Multiple high performance PLLs allow synthesis of unrelated frequencies
- Nonvolatile programming for personalization of PLL frequencies, spread spectrum characteristics, drive strength, crystal load capacitance, and output frequencies
- Application specific programmable electromagnetic interference (EMI) reduction using spread spectrum for clocks
- Programmable PLLs for system frequency margin tests
- Meets critical timing requirements in complex system designs
- Suitability for PC, consumer, portable, and networking applications
- Capable of zero parts per million (PPM) frequency synthesis error
- Uninterrupted system operation during clock frequency switch
- Application compatibility in standard and low power systems

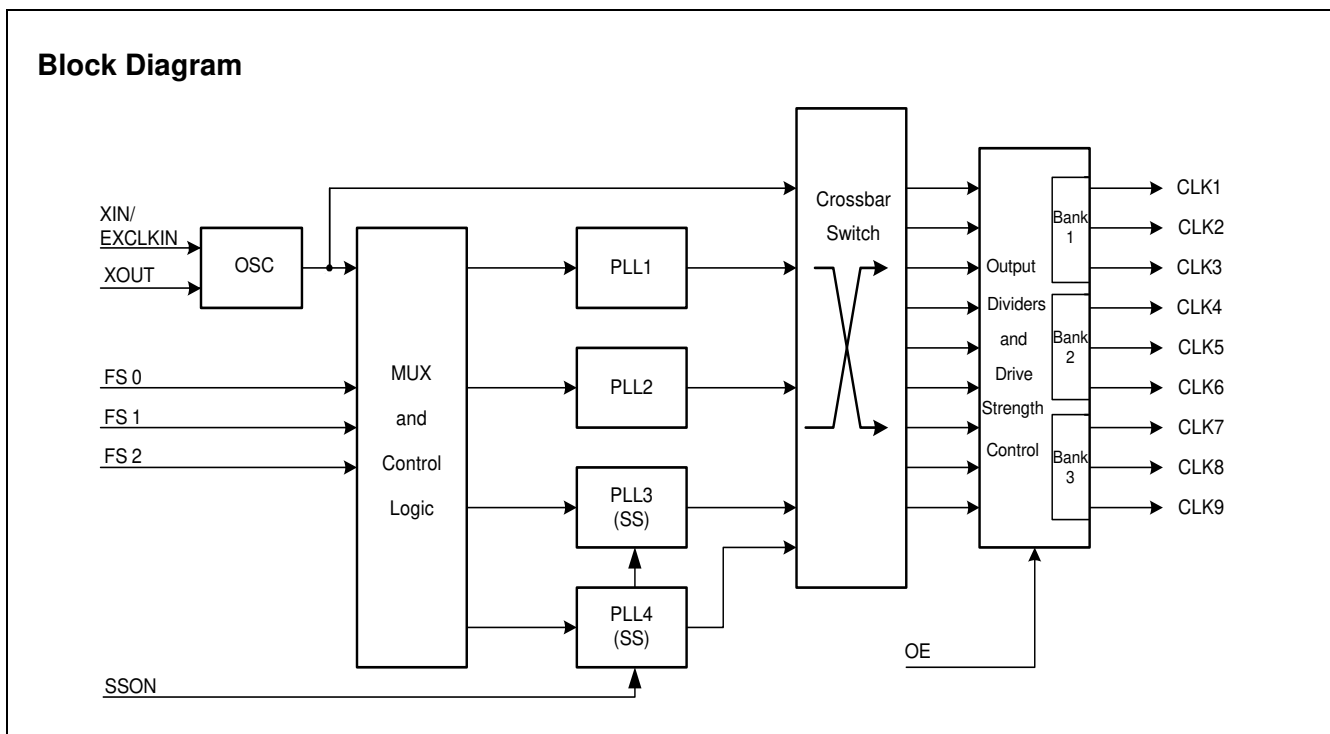

Contents

General Description	4	Recommended Crystal Specification	
Four Configurable PLLs	4	for Thru-Hole Package	7
Input Reference Clocks	4	AC Electrical Specifications	7
V _{DD} Power Supply Options	4	Test and Measurement Setup	8
Output Bank Settings	4	Voltage and Timing Definitions	8
Output Source Selection	4	Ordering Information	9
Spread Spectrum Control	4	Possible Configurations	9
Frequency Select	4	Ordering Code Definitions	9
Glitch-Free Frequency Switch	4	Package Drawing and Dimensions	10
Output Enable Mode	4	Acronyms	11
Output Drive Strength	4	Document Conventions	11
Generic Configuration and Custom Frequency	4	Units of Measure	11
Absolute Maximum Conditions	5	Document History Page	12
Recommended Operating Conditions	5	Sales, Solutions, and Legal Information	13
DC Electrical Specifications	6	Worldwide Sales and Design Support	13
Recommended Crystal Specification		Products	13
for SMD Package	7	PSoC Solutions	13

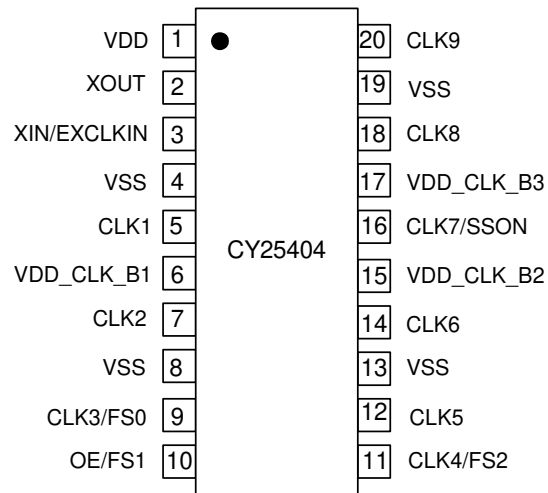
Figure 1. Pin Diagram - CY25404 20 LD TSSOP

Table 1. Pin Definition - CY25404 ($V_{DD} = 2.5\text{ V}, 3.0\text{ V}$ or 3.3 V Supply)

Pin Number	Name	IO	Description
1	V_{DD}	Power	Power supply: 2.5 V/3.0 V/3.3 V
2	XOUT	Output	Crystal output
3	XIN/EXCLKIN	Input	Crystal Input or 1.8 V external clock input
4	V_{SS}	Power	Power supply ground
5	CLK1	Output	Programmable clock output. Output voltage depends on $V_{DD_CLK_B1}$ voltage
6	$V_{DD_CLK_B1}$	Power	Power supply for Bank1, (CLK1, CLK2, CLK3) outputs: 2.5 V/3.0 V/3.3 V
7	CLK2	Output	Programmable clock output. Output voltage depends on $V_{DD_CLK_B1}$ voltage
8	V_{SS}	Power	Power supply ground
9	CLK3/FS0	Output/Input	Multifunction programmable pin: Programmable clock output or frequency select input pin. Output voltage of CLK3 depends on $V_{DD_CLK_B1}$ voltage
10	OE/FS1	Input	Multifunction programmable pin: High-true output enable or frequency select pin
11	CLK4/FS2	Output/Input	Multifunction programmable pin: Programmable clock output or frequency select input pin. Output voltage of CLK4 depends on $V_{DD_CLK_B2}$ Voltage
12	CLK5	Output	Programmable clock output. Output voltage depends on $V_{DD_CLK_B2}$ voltage
13	V_{SS}	Power	Power supply ground
14	CLK6	Output	Programmable clock output. Output voltage depends on $V_{DD_CLK_B2}$ voltage
15	$V_{DD_CLK_B2}$	Power	Power supply for Bank2, (CLK4, CLK5, CLK6) outputs: 2.5 V/3.0 V/3.3 V
16	CLK7/SSON	Output/Input	Multifunction programmable pin. Programmable clock output or spread spectrum On/OFF control input pin. Output voltage of CLK7 depends on $V_{DD_CLK_B3}$ voltage
17	$V_{DD_CLK_B3}$	Power	Power supply for Bank3, (CLK7, CLK8, CLK9) outputs: 2.5 V/3.0 V/3.3 V
18	CLK8	Output	Programmable clock output. Output voltage depends on $V_{DD_CLK_B3}$ voltage
19	V_{SS}	Power	Power supply ground
20	CLK9	Output	Programmable clock output. Output voltage depends on $V_{DD_CLK_B3}$ voltage

General Description

Four Configurable PLLs

The CY25404 has four programmable PLLs that can be used to generate output frequencies ranging from 3 to 166 MHz. The advantage of having four PLLs is that a single device generates up to four independent frequencies from a single crystal.

Input Reference Clocks

The input to the CY25404 can be either a crystal or a clock signal. The input frequency range for crystals is 8 MHz to 48 MHz, while that for clock signals is 8 MHz to 166 MHz. The required voltage level for the input reference clock (EXCLKIN) is shown in the DC and AC Electrical Specification tables.

V_{DD} Power Supply Options

This device has programmable power supply option and it can be programmed to operate at any voltage 2.5 V, 3.0 V, or 3.3 V.

Output Bank Settings

There are nine clock outputs grouped in three output driver banks. The Bank 1, Bank 2, and Bank 3 correspond to (CLK1, CLK2, CLK3), (CLK4, CLK5, CLK6), and (CLK7, CLK8, CLK9) respectively. Separate power supplies are used for each of these banks and they can be any of 2.5 V, 3.0 V, or 3.3 V. These voltages are independent of V_{DD} power supply used, giving user multiple choice of output clock voltage levels.

Output Source Selection

These devices have programmable input sources for each of its nine clock outputs (CLK1–9). There are five available clock sources for these outputs. These clock sources are: XIN/EXCLKIN, PLL1, PLL2, PLL3, or PLL4. Output clock source selection is done using four out of five crossbar switch. Thus, any one of these five available clock sources can be arbitrarily selected for the clock outputs. This gives user a flexibility to have up to four independent clock outputs.

Spread Spectrum Control

Two of the four PLLs (PLL3 and PLL4) have spread spectrum capability for EMI reduction in the system. The device uses a Cypress proprietary PLL and spread spectrum clock (SSC) technology to synthesize and modulate the frequency of the PLL. The spread spectrum feature can be turned on or off using a multifunction control pin (CLK7/SSON). It can be programmed to either center spread range from ±0.125% to ±2.50% or down spread range from –0.25% to –5.0% with Lexmark or Linear profile.

Frequency Select

There are three multifunction frequency select pins (FS0, FS1 and FS2) that provide an option to select eight different sets of frequencies among each of the four PLLs. Each output has programmable output divider options.

Glitch-Free Frequency Switch

When the frequency select pin (FS) is used to switch frequency, the outputs are glitch-free provided frequency is switched using output dividers. This feature enables uninterrupted system operation while clock frequency is being switched.

Output Enable Mode

There is a multifunction programmable pin 10, OE/FS1 that can be programmed to operate as output enable (OE) mode. OE is a high-true input and individual clock outputs can be programmed to be sensitive to this OE pin. If activated it shuts off the output drivers, resulting in minimum power consumption for the device.

Output Drive Strength

The DC drive strength of the individual clock output can be programmed for different values. Table 2 shows the typical rise and fall times for different drive strength settings.

Table 2. Output Drive Strength

Output Drive Strength	Rise/Fall Time (ns) (Typical Value)
Low	6.8
Mid Low	3.4
Mid High	2.0
High	1.0

Generic Configuration and Custom Frequency

There is a generic set of output frequencies available from the factory that can be used for the device evaluation purposes. The device, CY25404 can be custom programmed to any desired frequencies and listed features. For customer specific programming, please contact local cypress field application engineer (FAE) or sales representative.

Absolute Maximum Conditions

Parameter	Description	Condition	Min	Max	Unit
V _{DD}	Supply voltage	–	–0.5	4.5	V
V _{DD_CLK_BX}	Output bank supply voltage	–	–0.5	4.5	V
V _{IN}	Input voltage	Relative to V _{SS}	–0.5	V _{DD} +0.5	V
T _S	Temperature, storage	Non functional	–65	+150	°C
ESD _{HBM}	ESD protection (human body model)	JEDEC EIA/JESD22-A114-E	2000		volts
UL-94	Flammability rating	V-0 at 1/8 in.	–	10	ppm
MSL	Moisture sensitivity level	–		3	

Recommended Operating Conditions

Parameter	Description	Min	Typ	Max	Unit
V _{DD}	V _{DD} operating voltage	2.25	–	3.60	V
V _{DD_CLK_BX}	Output driver voltage for Bank 1, 2 and 3	2.25	–	3.60	V
T _{AC}	Commercial ambient temperature	0	–	+70	°C
T _{AI}	Industrial ambient temperature	–40	--	+85	°C
C _{LOAD}	Maximum load capacitance	–	–	15	pF
t _{PU}	Power-up time for all V _{DD} to reach minimum specified voltage (power ramps must be monotonic)	0.05	–	500	ms

Notes

1. Guaranteed by design but not 100% tested.
2. Configuration dependent.

DC Electrical Specifications

Parameter	Description	Conditions	Min	Typ	Max	Unit
V _{OL}	Output low voltage	I _{OL} = 2 mA, drive strength = [00]	-	-	0.4	V
		I _{OL} = 3 mA, drive strength = [01]				
		I _{OL} = 7 mA, drive strength = [10]				
		I _{OL} = 12 mA, drive strength = [11]				
V _{OH}	Output high voltage	I _{OH} = -2 mA, drive strength = [00]	V _{DD_CLK_BX} - 0.4	-	-	V
		I _{OH} = -3 mA, drive strength = [01]				
		I _{OH} = -7 mA, drive strength = [10]				
		I _{OH} = -12 mA, drive strength = [11]				
V _{IL1}	Input low voltage of FS0, OE/FS1, FS2, and SSON	-	-	-	0.2*V _{DD}	V
V _{IL2}	Input low voltage of EXCLKIN	-	-	-	0.18	V
V _{IH1}	Input high voltage of FS0, OE/FS1, FS2, and SSON	-	0.8*V _{DD}	-	-	V
V _{IH2}	Input high voltage of EXCLKIN	-	1.62	-	2.2	V
I _{IL1}	Input low current of OE/FS1 pin	V _{IL} = 0V	-	-	10	μA
I _{IH1}	Input high current of OE/FS1 pin	V _{IH} = V _{DD}	-	-	10	μA
I _{IL2}	Input low current of SSON, FS0 and FS2 pins	V _{IL} = 0V (Internal pull dn = 160k typ)	-	-	10	μA
I _{IH2}	Input high current of SSON, FS0, and FS2 pins	V _{IH} = V _{DD} (Internal pull dn = 160k typ)	14	-	36	μA
R _{DN}	Pull down resistor of SSON, FS0, and FS2 and off state (CLK1-CLK9) pins	Clock outputs in off-state by setting OE = Low	100	160	250	kΩ
I _{DD} ^[1,2]	Supply current for CY25404	OE = High, No load	-	22	-	mA
C _{IN} ^[1]	Input capacitance	SSON, CLKIN, FS0, OE/FS1, and FS2 pins	-	-	7	pF

AC Electrical Specifications

Parameter	Description	Conditions	Min	Typ	Max	Unit
F _{IN} (crystal)	Crystal frequency, XIN	–	8	–	48	MHz
F _{IN} (clock)	Input clock frequency, EXCLKIN	–	8	–	166	MHz
F _{CLK}	Output clock frequency	–	3	–	166	MHz
DC1	Output duty cycle, All clocks except Ref Out	Duty cycle is defined in Figure 3 on page 8 ; t ₁ /t ₂ , measured at 50% of V _{DD-CLK_BX}	45	50	55	%
DC2	Ref out duty cycle	Ref In Min 45%, Max 55%	40	–	60	%
T _{RF1} ^[1]	Output rise/fall time	Measured from 20% to 80% of V _{DD-CLK_BX} , as shown in Figure 4 on page 8 , C _{LOAD} = 15 pF, Drive strength [00]	–	6.8	–	ns
T _{RF2} ^[1]	Output rise/fall time	Measured from 20% to 80% of V _{DD-CLK_BX} , as shown in Figure 4 on page 8 , C _{LOAD} = 15 pF, Drive strength [01]	–	3.4	–	ns
T _{RF3} ^[1]	Output rise/fall time	Measured from 20% to 80% of V _{DD-CLK_BX} , as shown in Figure 4 on page 8 , C _{LOAD} = 15 pF, Drive strength [10]	–	2.0	–	ns
T _{RF4} ^[1]	Output rise/fall time	Measured from 20% to 80% of V _{DD-CLK_BX} , as shown in Figure 4 on page 8 , C _{LOAD} = 15 pF, Drive strength [11]	–	1.0	–	ns
T _{CCJ} ^[1,2]	Cycle-to-cycle jitter (peak)	Configuration dependent. See Table 3	–	100	–	ps
T _{LOCK} ^[1]	PLL lock time	Measured from 90% of the applied power supply level	–	1	3	ms

Table 3. Configuration Example for C-C Jitter

Ref. Freq. (MHz)	CLK1 Output		CLK2 Output		CLK3 Output		CLK4 Output		CLK5 Output	
	Freq. (MHz)	C-C Jitter Typ (ps)	Freq. (MHz)	C-C Jitter Typ (ps)	Freq. (MHz)	C-C Jitter Typ (ps)	Freq. (MHz)	C-C Jitter Typ (ps)	Freq. (MHz)	C-C Jitter Typ (ps)
14.3181	8.0	134	166	103	48	92	74.25	81	Not Used	
19.2	74.25	99	166	94	8	91	27	110	48	75
27	48	67	27	109	166	103	74.25	97	Not Used	
48	48	93	27	123	166	137	166	138	8	103

Recommended Crystal Specification for SMD Package

Parameter	Description	Range 1	Range 2	Range 3	Unit
F _{IN}	Crystal frequency	8 – 14	14 – 28	28 – 48	MHz
R1	Maximum motional resistance (ESR)	135	50	30	Ω
CL	Parallel load capacitance (device has internal load capacitance adjustment feature)	8 – 18	8 – 14	8 – 12	pF
DL(max)	Maximum crystal drive level	300	300	300	μW

Recommended Crystal Specification for Thru-Hole Package

Parameter	Description	Range 1	Range 2	Range 3	Unit
F _{IN}	Crystal frequency	8 – 14	14 – 24	24 – 32	MHz
R1	Maximum motional resistance (ESR)	90	50	30	Ω
CL	Parallel load capacitance (device has internal load capacitance adjustment feature)	8 – 18	8 – 12	8 – 12	pF
DL(max)	Maximum crystal drive level	1000	1000	1000	μW

Test and Measurement Setup

Figure 2. Test and Measurement Setup

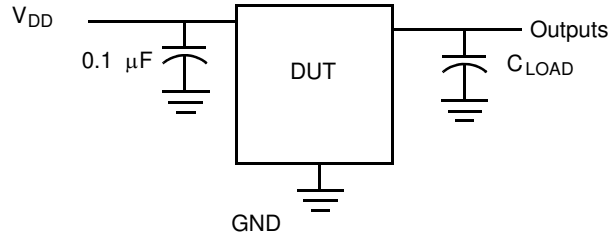

Voltage and Timing Definitions

Figure 3. Duty Cycle Definition

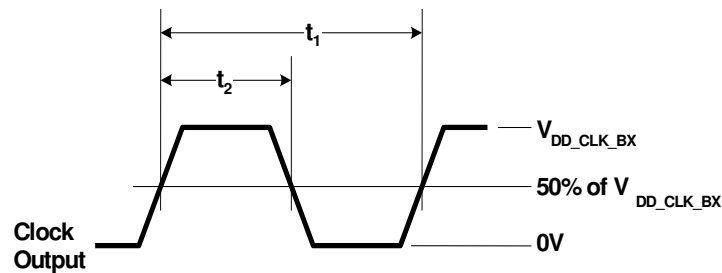
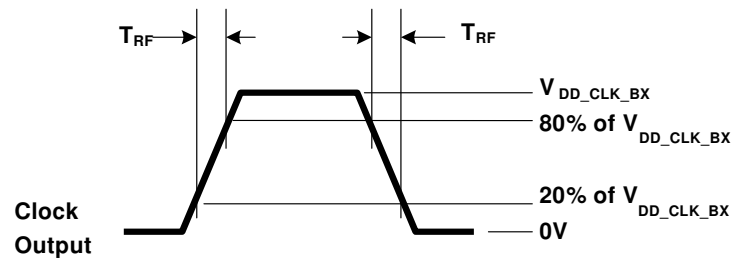

Figure 4. Rise Time = T_{RF} , Fall Time = T_{RF}



Ordering Information

Some product offerings are factory programmed customer specific devices with customized part numbers. The Possible Configurations table shows the available device types, but not complete part numbers. Contact your local Cypress FAE or Sales representative for more information.

Possible Configurations

Part Number ^[3]	Type	Production Flow
Pb-free		
CY25404ZXC-xxx	20-pin TSSOP	Commercial, 0 °C to 70 °C
CY25404ZXC-xxxT	20-pin TSSOP -Tape and Reel	Commercial, 0 °C to 70 °C
CY25404ZXI-xxx	20-pin TSSOP	Industrial, -40 °C to +85 °C
CY25404ZXI-xxxT	20-pin TSSOP -Tape and Reel	Industrial, -40 °C to +85 °C

Ordering Code Definitions

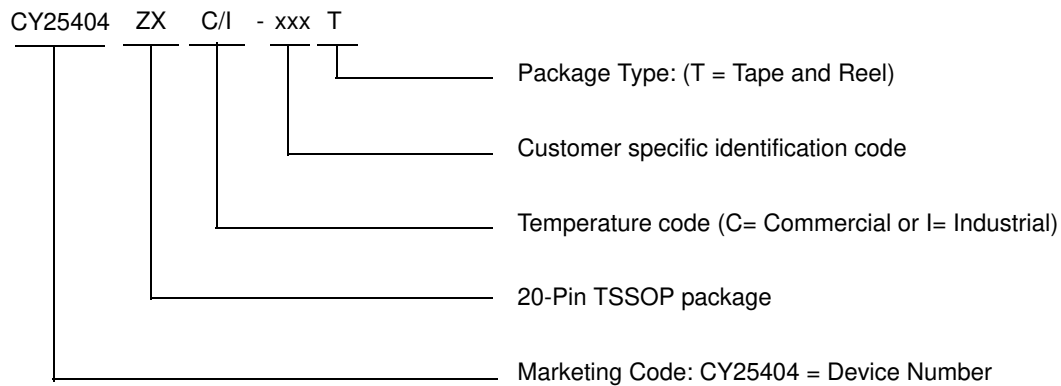

Note

3. xxx indicates Factory Programmable and are factory programmed configurations. For more details, contact your local Cypress FAE or Cypress Sales Representative.

Package Drawing and Dimensions

Figure 5. 20-LD TSSOP, Thin Shrunken Small Outline Package (4.40 mm Body) ZZ2

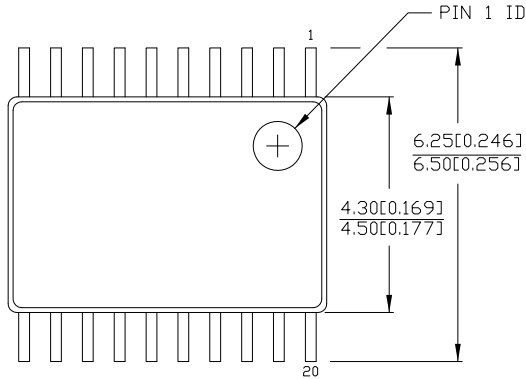

DIMENSIONS IN MM [INCHES] MIN. MAX.

REFERENCE JEDEC MO-153

PART #	
Z20.173	STANDARD PKG.
ZZ20.173	LEAD FREE PKG.

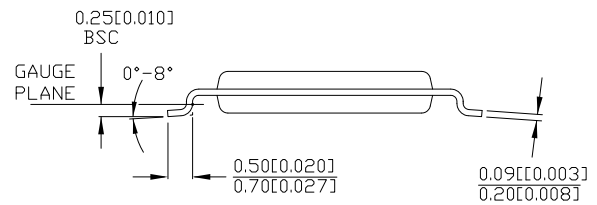
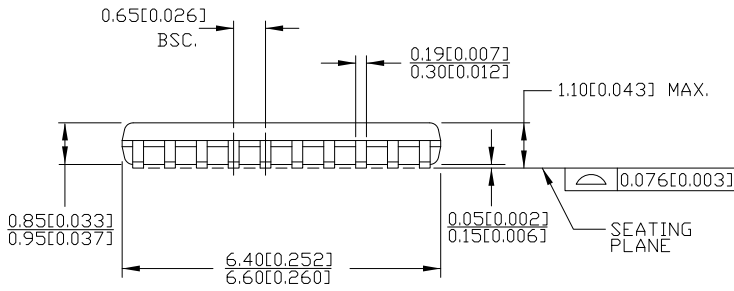

51-85118 *C

Acronyms

Acronym	Description
DL	drive level
EMI	electromagnetic interference
ESD	electrostatic discharge
FAE	field application engineer
FS	frequency select
JEDEC EIA	joint electron devices engineering council electronic industries alliance
OE	output enable
OSC	oscillator
PD	power-down
PLL	phase-locked loop
PPM	parts per million
SS	spread spectrum
SSC	spread spectrum clock
SSON	spread spectrum on
TSSOP	thin shrunk small outline package

Document Conventions

Units of Measure

Symbol	Unit of Measure
°C	degrees Celsius
fF	femtofarads
mA	milliampere
MHz	megahertz
μs	microseconds
ms	millisecond
μW	microwatts
ns	nanoseconds
pF	picofarads
ppm	parts per million
ps	picoseconds
V	volts
Ω	ohms
W	watts

Document History Page

Document Title: CY25404 Quad PLL Programmable Clock Generator with Spread Spectrum Document Number: 001-43258				
REV.	ECN NO.	Issue Date	Orig. of Change	Description of Change
**	1793805	See ECN	DPF/AESA	New data sheet
*A	2748211	08/10/09	TSAI	Posting to external web.
*B	2899300	03/26/2010	CXQ	Updated Ordering Information. Added note regarding Possible Configurations in Ordering Information section. Added Possible Configurations table for 'xxx' parts. Updated Package Drawing and Dimensions
*C	3308261	07/11/2011	BASH	Added Ordering Code Definitions Updated Package Drawing and Dimensions Added Acronyms Added Units of Measure Added Contents

Sales, Solutions, and Legal Information

Worldwide Sales and Design Support

Cypress maintains a worldwide network of offices, solution centers, manufacturer's representatives, and distributors. To find the office closest to you, visit us at [Cypress Locations](#).

Products

Automotive	cypress.com/go/automotive
Clocks & Buffers	cypress.com/go/clocks
Interface	cypress.com/go/interface
Lighting & Power Control	cypress.com/go/powerpsoc cypress.com/go/plc
Memory	cypress.com/go/memory
Optical & Image Sensing	cypress.com/go/image
PSoC	cypress.com/go/psoc
Touch Sensing	cypress.com/go/touch
USB Controllers	cypress.com/go/USB
Wireless/RF	cypress.com/go/wireless

PSoC Solutions

psoc.cypress.com/solutions
PSoC 1 | PSoC 3 | PSoC 5

© Cypress Semiconductor Corporation, 2007-2011. The information contained herein is subject to change without notice. Cypress Semiconductor Corporation assumes no responsibility for the use of any circuitry other than circuitry embodied in a Cypress product. Nor does it convey or imply any license under patent or other rights. Cypress products are not warranted nor intended to be used for medical, life support, life saving, critical control or safety applications, unless pursuant to an express written agreement with Cypress. Furthermore, Cypress does not authorize its products for use as critical components in life-support systems where a malfunction or failure may reasonably be expected to result in significant injury to the user. The inclusion of Cypress products in life-support systems application implies that the manufacturer assumes all risk of such use and in doing so indemnifies Cypress against all charges.

Any Source Code (software and/or firmware) is owned by Cypress Semiconductor Corporation (Cypress) and is protected by and subject to worldwide patent protection (United States and foreign), United States copyright laws and international treaty provisions. Cypress hereby grants to licensee a personal, non-exclusive, non-transferable license to copy, use, modify, create derivative works of, and compile the Cypress Source Code and derivative works for the sole purpose of creating custom software and or firmware in support of licensee product to be used only in conjunction with a Cypress integrated circuit as specified in the applicable agreement. Any reproduction, modification, translation, compilation, or representation of this Source Code except as specified above is prohibited without the express written permission of Cypress.

Disclaimer: CYPRESS MAKES NO WARRANTY OF ANY KIND, EXPRESS OR IMPLIED, WITH REGARD TO THIS MATERIAL, INCLUDING, BUT NOT LIMITED TO, THE IMPLIED WARRANTIES OF MERCHANTABILITY AND FITNESS FOR A PARTICULAR PURPOSE. Cypress reserves the right to make changes without further notice to the materials described herein. Cypress does not assume any liability arising out of the application or use of any product or circuit described herein. Cypress does not authorize its products for use as critical components in life-support systems where a malfunction or failure may reasonably be expected to result in significant injury to the user. The inclusion of Cypress' product in a life-support systems application implies that the manufacturer assumes all risk of such use and in doing so indemnifies Cypress against all charges.

Use may be limited by and subject to the applicable Cypress software license agreement.