

# **Instruction manual for Evaluation Board - TB67S128FTG -**

December 20th, 2018

Rev.1.0

## 【Outline】

The TB67S128FTG is a two-phase bipolar stepping motor driver using a PWM chopper. CLK-IN control system and BiCD process are adopted. Rating of 50 V and 4.5 A is realized.

This evaluation board mounts necessary components to evaluate the IC. Each excitation mode of full step, half step, quarter step 1/8 step, 1/16 step, and 1/32 step is possible with PWM constant current drive. Please sense low-noise and low-vibration drive of stepping motors applying the TB67S128FTG.

## 【Note】

In using, please be careful about the thermal condition sufficiently. As for each control signal, please refer to the IC specification by accessing to the below URL.

<https://toshiba.semicon-storage.com/us/product/linear/motordriver/detail.TB67S128FTG.html>

Further, the application of this evaluation board is limited to the purpose of evaluating and learning the motor control. Please do not ship them to a market.

# Connection to evaluation board

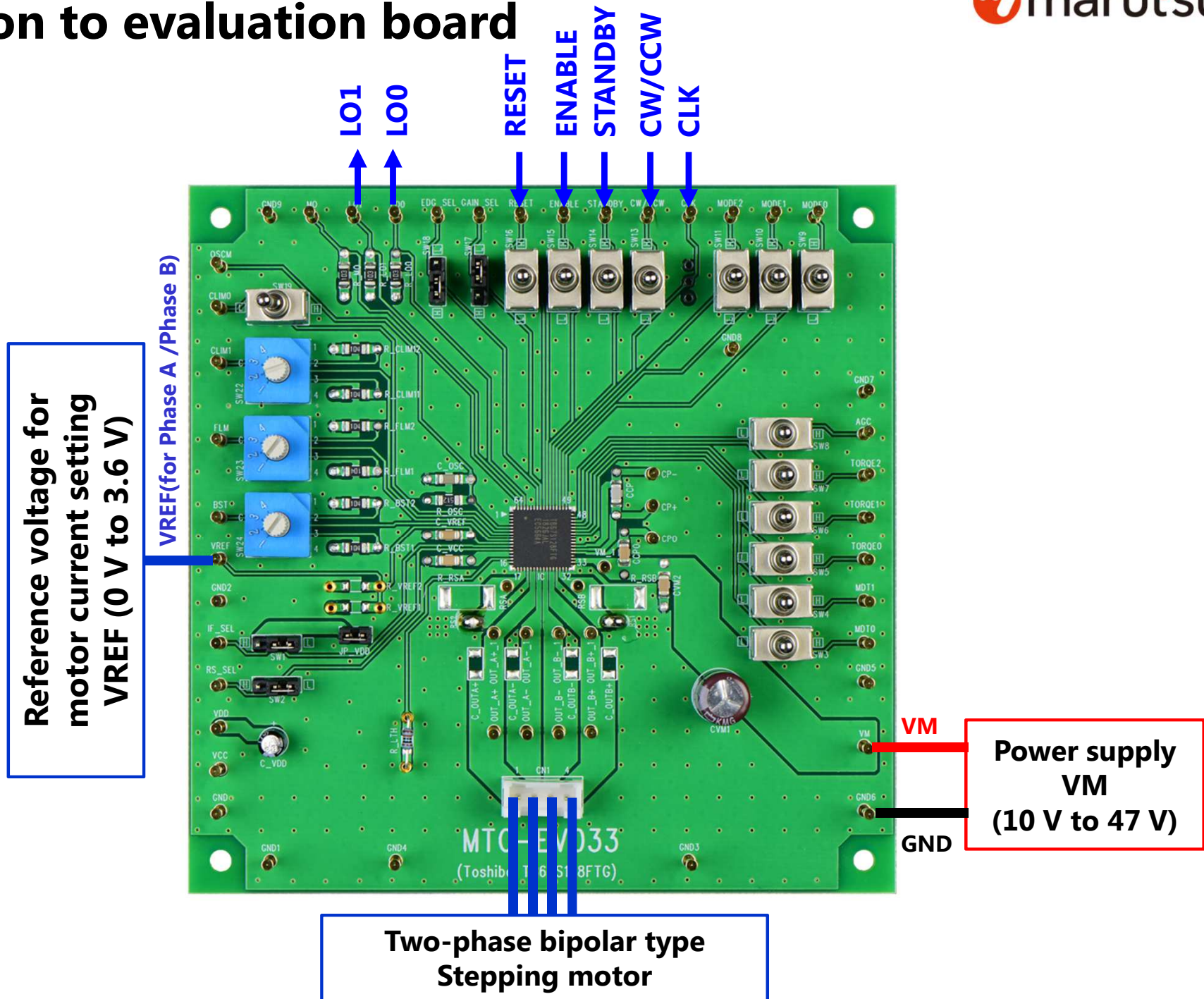

# Connection to evaluation board

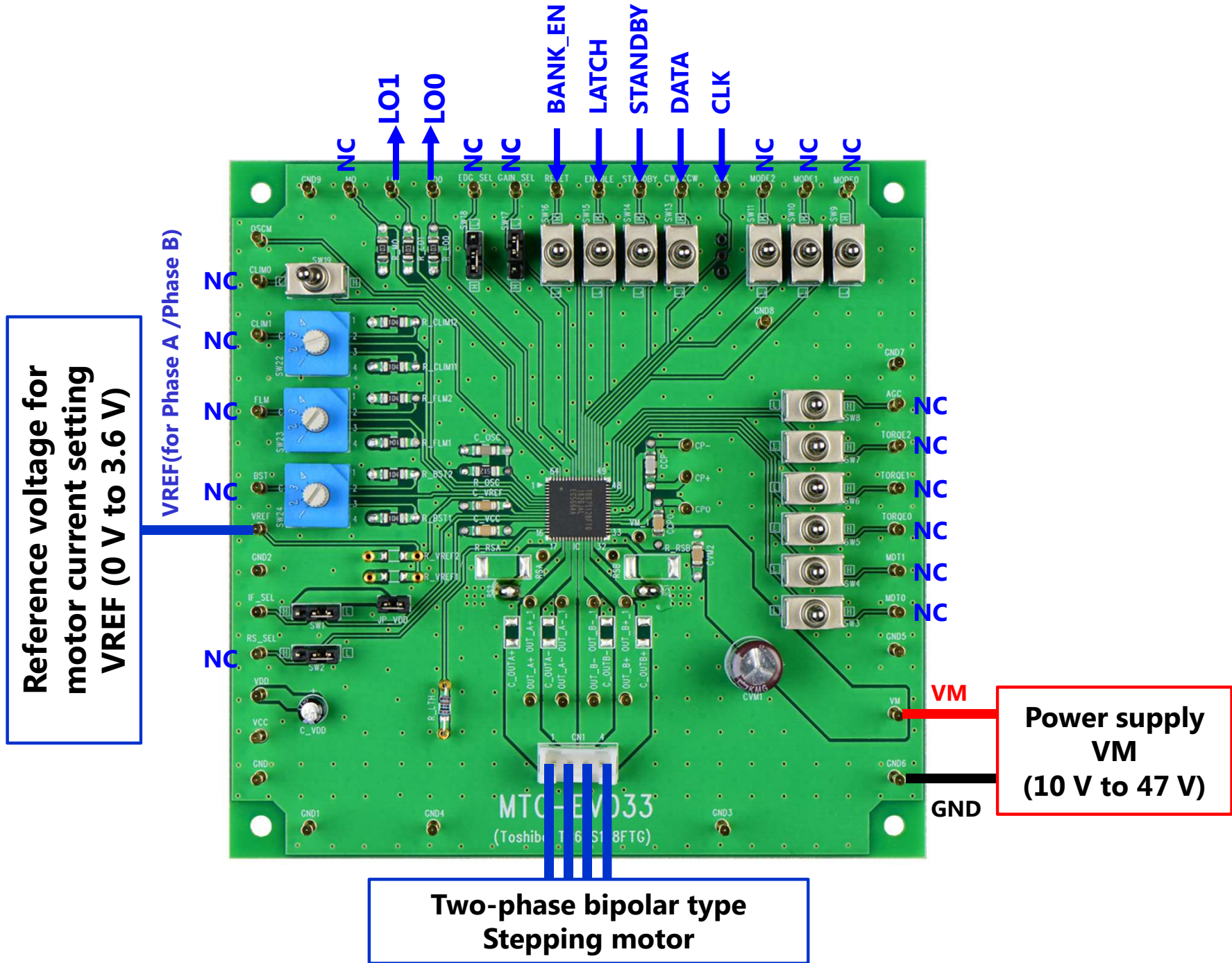

# Setting evaluation board 1

## Setting motor current

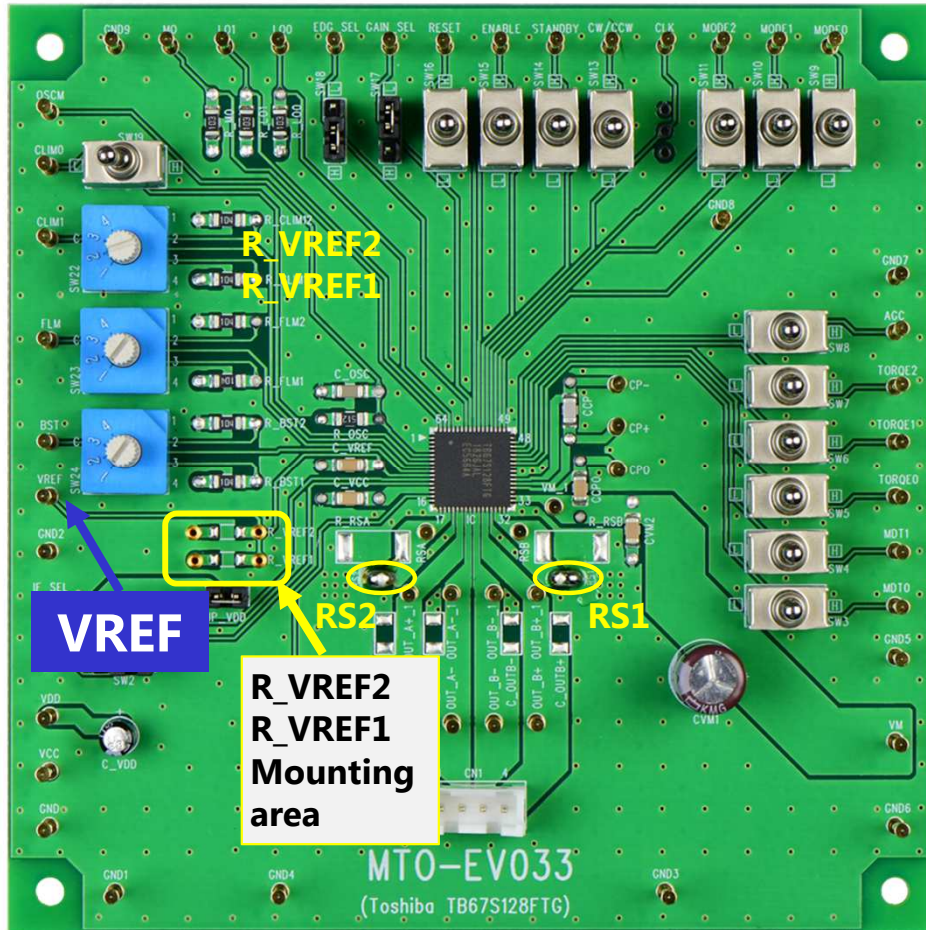

## Setting motor current

① ACDS (RS resistor less) mode: RS\_SEL=Low

GAIN\_SEL=Low:

$$I_{out(max)} = 1.56 \times V_{REF}(V)$$

GAIN\_SEL=High:

$$I_{out(max)} = 0.78 \times V_{REF}(V)$$

② External sense RS resistor mode: RS\_SEL=High

$$I_{out(max)} = V_{REF(gain)} \times \frac{V_{ref}(V)}{R_{RS}(\Omega)}$$

GAIN\_SEL=Low : VREF(gain) is 1/5.0 (typ.).

GAIN\_SEL=High : VREF(gain) is 1/10.0 (typ.).

On this evaluation board, external components are mounted based on ACDS mode. When uses external sense RS resistor mode, please remove solder from short round of RS1 and RS2. And please mount external current sense resistor on R\_RSA and R\_RSB.

When uses VCC voltage for generating VREF, please add dividing voltage resistors to mounting area of R\_VREF2 and R\_VREF1.

## Waveform of motor current

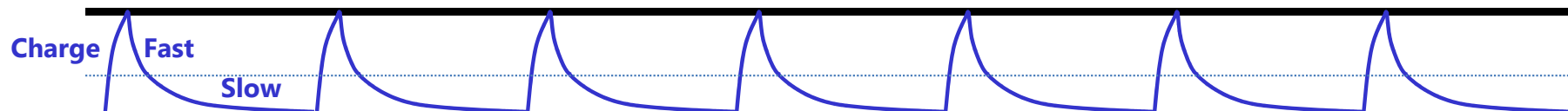

## Current value of setting motor

# Setting evaluation board 2

## Setting chopping frequency of the constant current of the motor

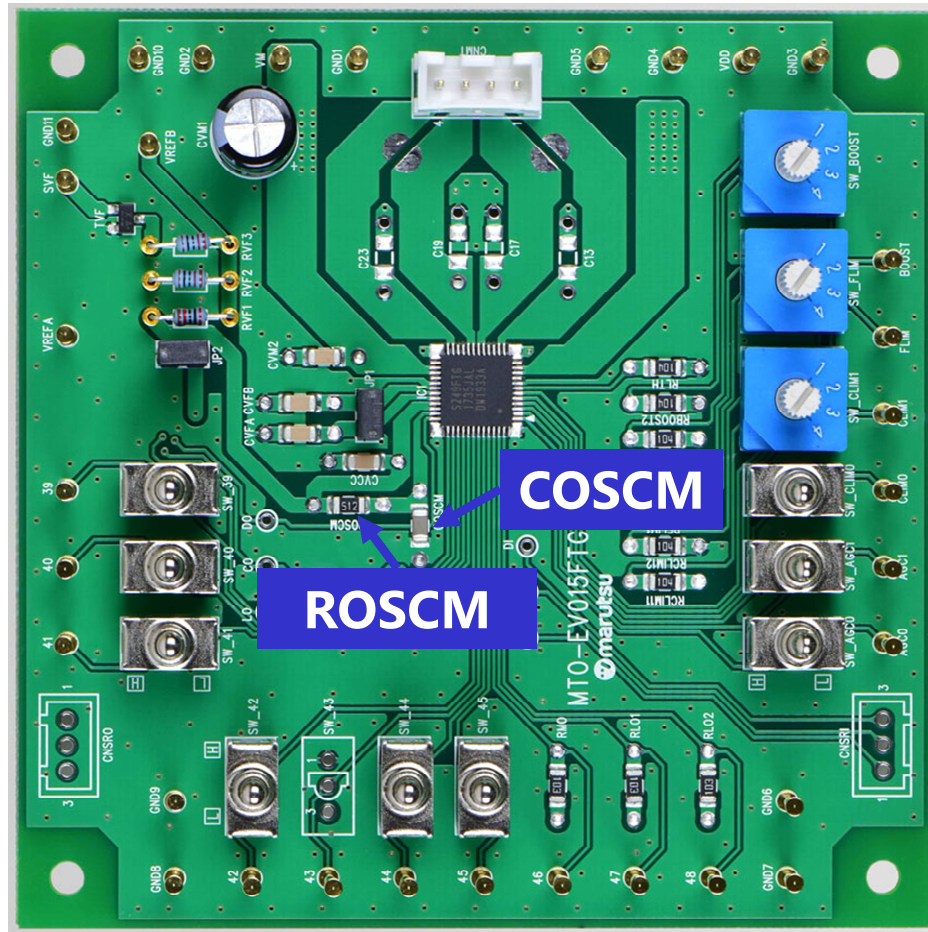

### Formula of setting chopping frequency

$$f_{OSCM} \text{ [MHz]} = 4.0 \times ROSC \text{ [k}\Omega\text{]}^{(-0.8)}$$

$$f_{chop} = f_{OSCM} / 16$$

COSC = 270 pF (fix)

Mounted components are as follows;

Capacitor (OSCM=270 pF)

Resistor (ROSCM=5.1 kΩ)

### Waveform of motor current

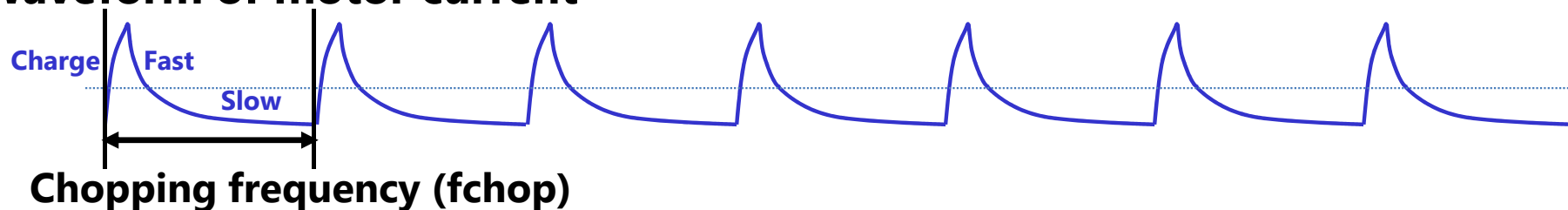

# Setting evaluation board 3

## Setting motor operation

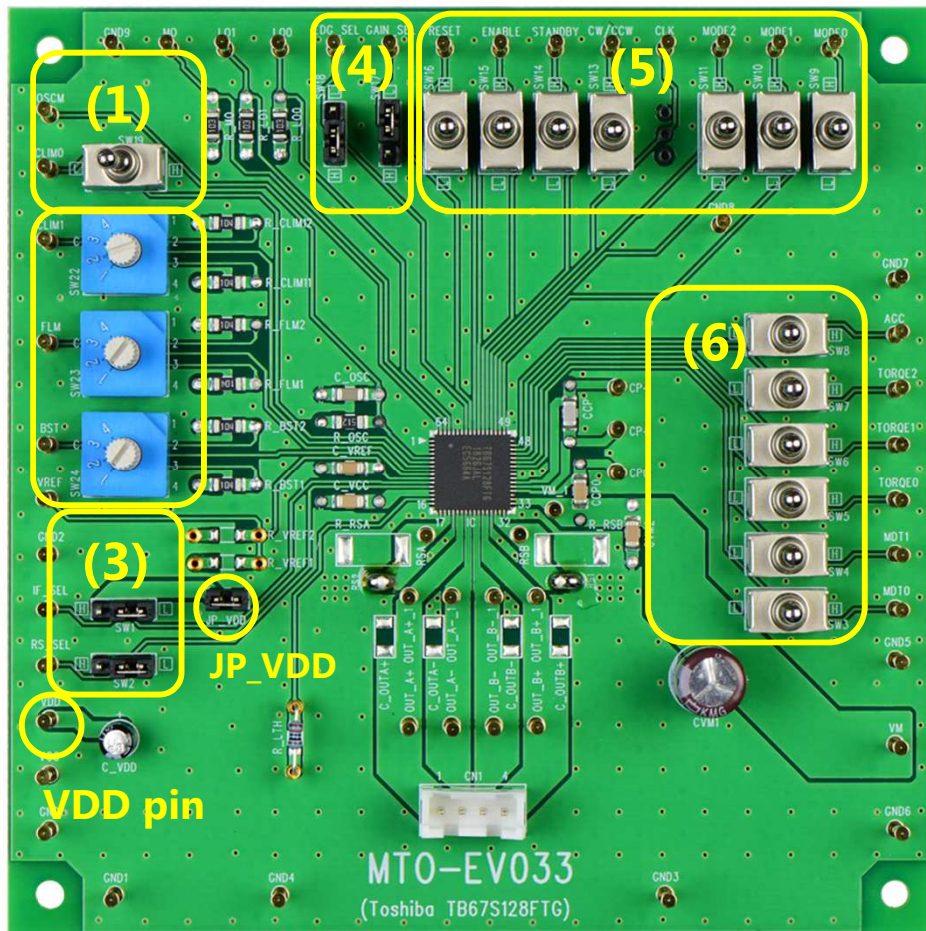

Three-position toggle switches ((1), (5), and (6) in the left diagram) and level select pins ((3) and (4)) for setting the operation of the TB67S128FTG and a rotary switch ((2) in the left figure) for adjusting the AGC function are mounted. In using these switches, short-circuit the jumper of JP\_VDD (i.e. initialize) or supply 5-V voltage from the VDD pin.

### 【Switches of (1) and (6)】

Tilting rightward: High level

Tilting leftward: Low level

Middle position Neutral. The input signal from the pins is valid.

### 【Switches of (5)】

Tilting downward: Low level

Tilting upward: High level

Middle position Neutral. The input signal from the pins is valid.

### 【Switch of (2)】

Four states can be selected by this rotary switch.

Position 1: Connecting to GND.

Position 2: Connecting to GND through a resistor of 100 kΩ.

Position 3: Connecting to VDD through a resistor of 100 kΩ.

Position 4: Connecting to VDD.

### 【Switch of (3)】

Short to leftward: Low level

Short to rightward: High level

Remove short pins, the input signal from the pins is valid.

### 【Switch of (4)】

Short to upward: Low level

Short to downward: High level

Remove short pins, the input signal from the pins is valid.

※Refer to the datasheet for information on how to use and set each function.

# Circuit of evaluation board

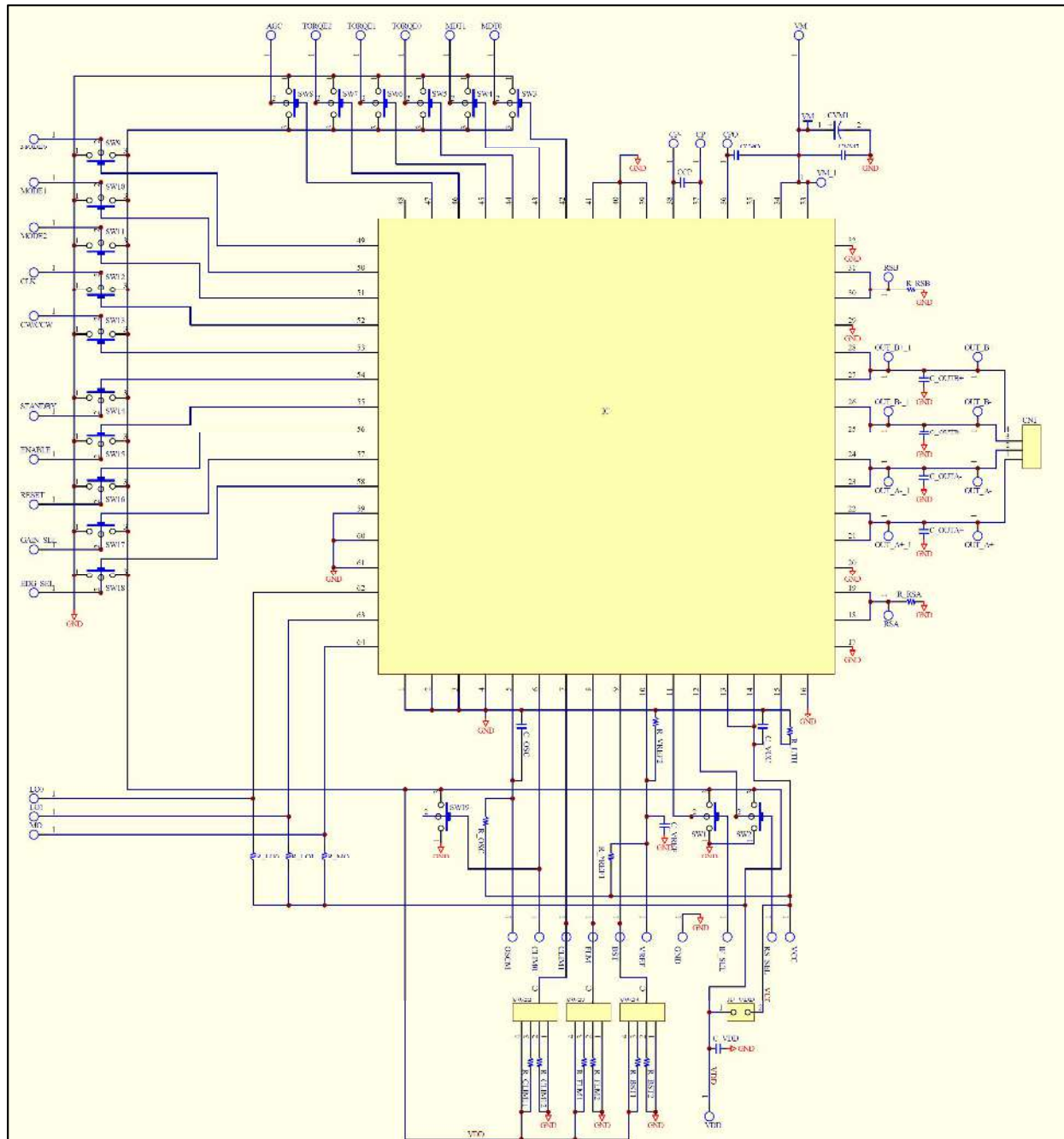



◆ Important Note ◆

● This product was not designed for use with devices which could cause personal injury in the event of failure or malfunction, including devices for use in areas including medical, military, aviation, aerospace, nuclear control, other types of safety mechanisms, etc., or for use in devices which require a high standard of safety. Do not use this product for such applications. This company assumes no liability for damages which may result from use of the product.

Manufactured and Distributed by



Marutsuelec Co., Ltd.

5-2-2, Seiki Daiichi Building 7F, Sotokanda, Chiyoda-ku,  
Tokyo 101-0021, Japan

Tel:+81-3-6803-0209 FAX:+81-3-6803-0213

Sendai Kamisugi store, Akihabara store, Akihabara store number 2, West Tokyo Office, Shizuoka Yahata store,  
Hamamatsu Takabayashi store, Nagoya Otai store, Kanazawanishi interchange store, Fukui Ninomiya store,  
Kyoto Teramachi store, Osaka Nipponbashi store, Hakata Gofukumachi store, marutsu online