

### Polypropylene & Foil Resonant Power Supply Capacitors

Specifically designed to meet higher current carrying requirements of resonant power circuits.



#### FEATURES

- Higher Current Carrying Capability
- Minimum Inductance Lower Impedance and ESR
- Five Case Sizes
- Compact configuration
- Direct Plug-in Spade Lugs

# Specification Summary

## Capacitance Range

0.010 $\mu$ F to 0.100 $\mu$ F

## Capacitance Tolerance

Standard capacitance tolerance is  $\pm 10\%$ . Tolerances of  $\pm 5\%$ ,  $\pm 2\%$  and  $\pm 1\%$  are also available.

## Operating Temperature Range

-55°C to +105°C

## Enclosure/Construction

Extended Foil

## Voltage Rating

400 VDC to 1500 VDC

230 VAC to 460 VAC

## Quality Control

Capacitors are tested 100% for:

- Capacitance
- Tolerance
- Dissipation Factor
- Dielectric withstanding voltage
- Insulation Resistance

Process and inspection data are maintained on file and available upon special request.

## Environmental

Parameter	Method	Condition
Vibration	204	D
Shock	213	I
Humidity	106	-
Thermal Shock	107	A
Life	108	F

Reference MIL-STD-202

# Characteristics

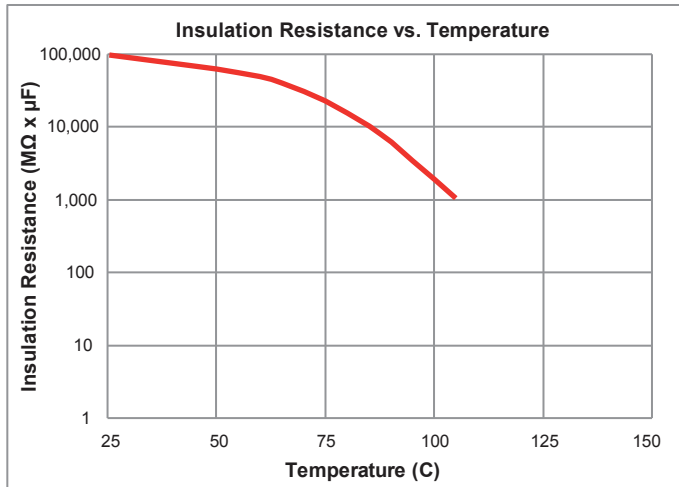

## Dielectric Strength

Capacitors withstand a DC potential of 1.5 x rated voltage for one (1) minute without damage or breakdown. Test voltage is applied and discharged through a minimum resistance of 100 OHMS per volt minimum.

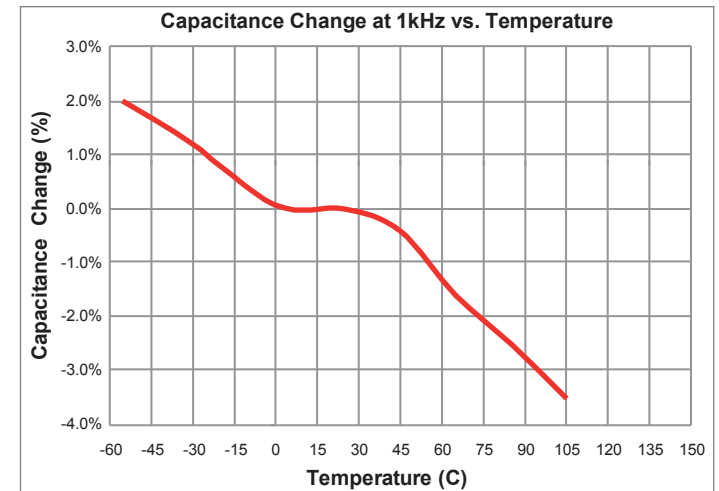

## Dissipation Factor

When measured at the frequency specified for capacitance measurement, the dissipation factor will not exceed 0.05%.

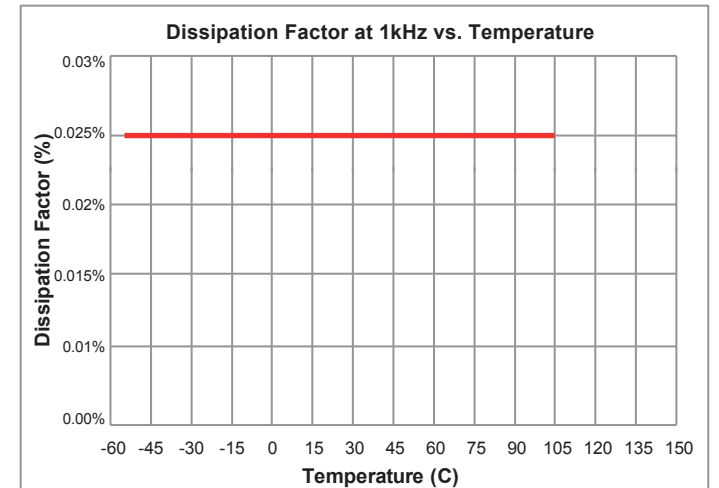

# Detail Data

PART NUMBER	CAP μF	VOLTAGE VDC	VOLTAGE VAC	ESR (ohms) 100 kHz	100kHz (Arms)		dv/dt V/μs	I PEAK (AMPS)	ESL (nH)	Fres (MHz)	CASE NO.
					25°C	85°C					
5PT46J103_	0.010	400	230	0.016	10.0	4.0	27,937	279	8.6	17.2	1
5PT46J123_	0.012	400	230	0.013	11.0	4.4	27,937	335	8.6	15.7	1
5PT46J153_	0.015	400	230	0.011	12.3	4.9	23,280	349	8.6	14.0	1
5PT46J183_	0.018	400	230	0.009	13.4	5.4	23,280	419	8.6	12.8	1
5PT46J223_	0.022	400	230	0.007	14.8	5.9	18,624	410	8.6	11.6	1
5PT46J273_	0.027	400	230	0.006	16.4	6.6	18,624	503	8.6	10.4	1
5PT46J333_	0.033	400	230	0.005	18.2	7.3	16,296	538	8.6	9.4	1
5PT46J393_	0.039	400	230	0.004	19.8	7.9	13,968	545	8.6	8.7	1
5PT46J473_	0.047	400	230	0.003	21.7	8.7	11,640	608	8.6	7.9	1
5PT46J563_	0.056	400	230	0.003	23.7	9.5	11,640	652	8.6	7.3	1
5PT46J683_	0.068	400	230	0.002	26.1	10.4	10,476	712	8.6	6.6	1
5PT46J823_	0.082	400	230	0.002	28.7	11.5	10,476	859	8.6	6.0	1
5PT46J104_	0.100	400	230	0.002	31.7	12.7	9,209	921	8.6	5.4	1
5PT46N103_	0.010	800	460	0.016	11.3	4.5	37,580	376	17.2	12.1	2
5PT46N123_	0.012	800	460	0.013	12.4	5.0	34,448	413	17.2	11.1	2
5PT46N153_	0.015	800	460	0.011	13.9	5.5	31,317	470	17.2	9.9	2
5PT46N183_	0.018	800	460	0.009	15.2	6.1	28,185	507	17.2	9.0	2
5PT46N223_	0.022	800	460	0.007	16.8	6.7	25,053	551	17.2	8.2	2
5PT46N273_	0.027	800	460	0.006	18.6	7.4	20,356	550	17.2	7.4	2
5PT46N333_	0.033	800	460	0.005	20.6	8.2	18,790	620	17.2	6.7	2
5PT46N393_	0.039	800	460	0.004	22.4	8.9	17,224	672	17.2	6.1	2
5PT46N473_	0.047	800	460	0.003	24.6	9.8	15,658	736	17.2	5.6	2
5PT46N563_	0.056	800	460	0.003	28.1	11.3	13,005	728	20.6	4.7	3
5PT46N683_	0.068	800	460	0.002	31.0	12.4	10,837	737	20.6	4.2	3
5PT46N823_	0.082	800	460	0.002	34.0	13.6	9,754	800	20.6	3.9	3
5PT46N104_	0.100	800	460	0.002	37.6	15.0	9,754	975	20.6	3.5	3
5PT46L103_	0.010	1200	460	0.016	11.3	4.5	37,580	376	17.2	12.1	2
5PT46L123_	0.012	1200	460	0.013	12.4	5.0	34,448	413	17.2	11.1	2
5PT46L153_	0.015	1200	460	0.011	13.9	5.5	31,317	470	17.2	9.9	2
5PT46L183_	0.018	1200	460	0.009	15.2	6.1	28,185	507	17.2	9.0	2
5PT46L223_	0.022	1200	460	0.007	16.8	6.7	25,053	551	17.2	8.2	2
5PT46L273_	0.027	1200	460	0.006	19.5	7.8	17,340	468	20.6	6.7	3
5PT46L333_	0.033	1200	460	0.005	21.6	8.6	17,340	572	20.6	6.1	3
5PT46L393_	0.039	1200	460	0.004	23.5	9.4	15,172	592	20.6	5.6	3
5PT46L473_	0.047	1200	460	0.003	28.9	11.6	14,901	700	24.1	4.7	4
5PT46L563_	0.056	1200	460	0.003	31.6	12.6	14,901	834	24.1	4.3	4
5PT46L683_	0.068	1200	460	0.002	34.8	13.9	13,246	901	24.1	3.9	4
5PT46L823_	0.082	1200	460	0.002	38.2	15.3	11,590	950	24.1	3.6	4
5PT46L104_	0.100	1200	460	0.002	45.1	18.0	11,255	1125	27.5	3.0	5
5PT46M103_	0.010	1500	460	0.016	11.3	4.5	37,580	376	17.2	12.1	2
5PT46M123_	0.012	1500	460	0.013	12.4	5.0	34,448	413	17.2	11.1	2
5PT46M153_	0.015	1500	460	0.011	13.9	5.5	31,317	470	17.2	9.9	2
5PT46M183_	0.018	1500	460	0.009	15.2	6.1	28,185	507	17.2	9.0	2
5PT46M223_	0.022	1500	460	0.007	17.6	7.1	19,507	429	20.6	7.5	3
5PT46M273_	0.027	1500	460	0.006	19.5	7.8	17,340	468	20.6	6.7	3
5PT46M333_	0.033	1500	460	0.005	21.6	8.6	17,340	572	20.6	6.1	3
5PT46M393_	0.039	1500	460	0.004	26.3	10.5	14,069	549	24.1	5.2	4
5PT46M473_	0.047	1500	460	0.003	28.9	11.6	14,901	700	24.1	4.7	4
5PT46M563_	0.056	1500	460	0.003	31.6	12.6	14,901	834	24.1	4.3	4
5PT46M683_	0.068	1500	460	0.002	34.8	13.9	13,246	901	24.1	3.9	4
5PT46M823_	0.082	1500	460	0.002	40.9	16.3	12,662	1038	27.5	3.4	5
5PT46M104_	0.100	1500	460	0.002	45.1	18.0	11,255	1125	27.5	3.0	5

# Mechanical Data

CASE NO.	TH		H		L		LS	
	in. ±0.010	mm ±0.254	in. max	mm max	in. ±0.010	mm ±0.254	in. ±0.010	mm ±0.254
1	0.500	12.700	0.730	18.542	0.645	16.383	0.500	12.700
2	0.500	12.700	0.730	18.542	1.250	31.750	1.000	25.400
3	0.530	13.462	0.780	19.812	1.400	35.560	1.200	30.480
4	0.625	15.875	0.980	24.892	1.625	41.275	1.400	35.560
5	0.800	20.320	0.980	24.892	1.750	44.450	1.600	40.640

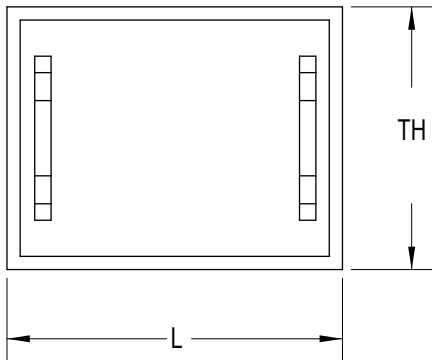

PINS ARE  $1.270 \pm .127\text{mm}$   
 $(0.050 \pm .005\text{")}$   
 TAPERED TO  $0.889 \pm .076\text{mm}$   
 $(0.035 \pm .003\text{")}$

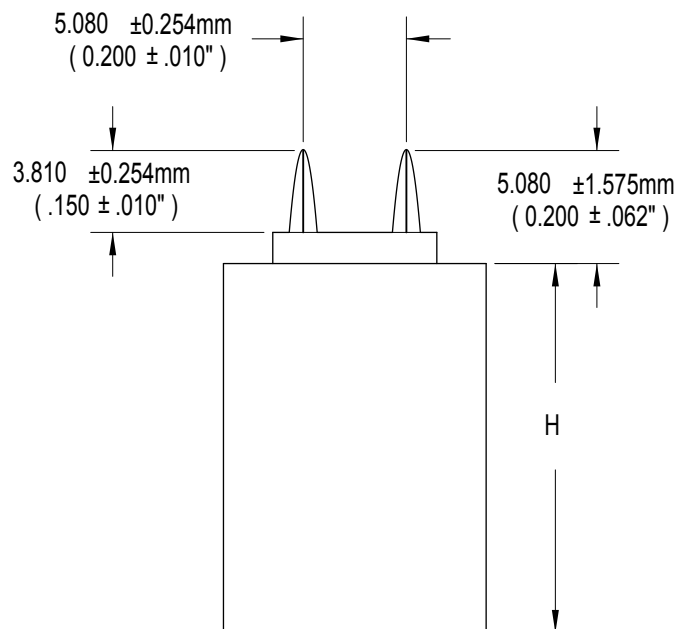
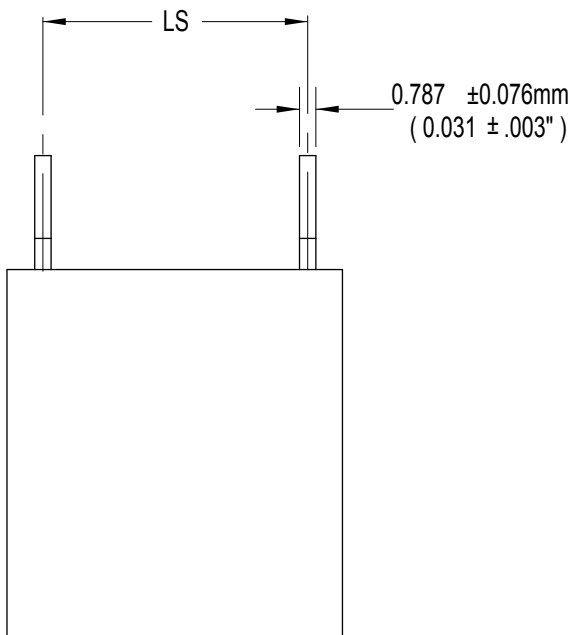
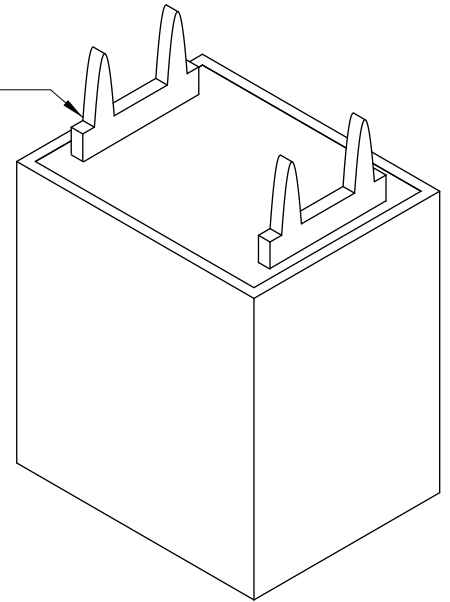

## Additional Information

Its uniquely shaped lugs are mechanically sturdy and able to accommodate higher current with minimum inductance. The termination lugs are also a direct "plug-in" type which adds to overall performance efficiency.

With the advent of the 5PT, the designer can maximize frequency characteristics -- and at the same time simplify system design with miniaturization, reduce assembly work -- plus realize significant overall system cost savings.

## How to Order

TYPE Polypropylene & Foil	→	<b>5PT46</b>
VOLTAGE J = 400VDC; N = 800VDC; etc.	→	<b>J</b>
CAPACITANCE IN PICOFARADS The first two digits are significant, the third represents the number of zeros	→	<b>103</b>
TOLERANCE K = ±10%. Tolerances of ±5%, ±2%, and ±1% are also available.	→	<b>K</b>

### Marking And Date Code

All capacitors are marked with company initials "EC", corporate logo or EC trademark—in addition to type 5PT, capacitance, tolerance, rated DC working voltage and date code. The first two digits of the date code represent the year, the second two digits the week, i.e., 1252 is the 52nd week of 2012, 1202 is the second week of 2012.

### Quality Assurance

Major emphasis is placed on quality assurance. EC is an ISO 9001 and AS9100 Certified Company. Raw material inspection and the use of SPC manufacturing procedures assure the highest quality standards. Procedures are fully described in the EC Quality Control Manual. Electronic Concepts will continue to advance the state-of-the-art by utilizing leading edge technology, compact capacitor designs and establishing reliability procedures.

## Sales Offices

### United States Headquarters

Electronic Concepts, Inc.  
526 Industrial Way West  
Eatontown, NJ 07724  
Tel: 732-542-7880  
Fax: 732-542-0524

email: [sales@ecicaps.com](mailto:sales@ecicaps.com)  
website: [www.ecicaps.com](http://www.ecicaps.com)

### Distribution Center

Elcon Sales  
542 Industrial Way West  
Eatontown, NJ 07724  
Tel: 732-380-0405  
Fax: 732-380-0409

email: [sales@elconsales.com](mailto:sales@elconsales.com)

### European Headquarters

Electronic Concepts Europe LTD  
IDA Estate  
Oughterard  
Co. Galway  
Ireland  
tel: +353-91-552385,552432  
fax: +353-91-552387

email: [sales@ecicaps.ie](mailto:sales@ecicaps.ie)  
website: [www.electronicconcepts.ie](http://www.electronicconcepts.ie)

