

THIS DRAWING IS UNPUBLISHED. RELEASED FOR PUBLICATION
 © COPYRIGHT BY TYCO ELECTRONICS CORPORATION. ALL RIGHTS RESERVED.

LOC	DIST	REVISIONS			
P	LTR	DESCRIPTION	DATE	DWN	APVD
AJ	16	K	REVISED PER ECO-07-002853	21MAR2007	DW JL

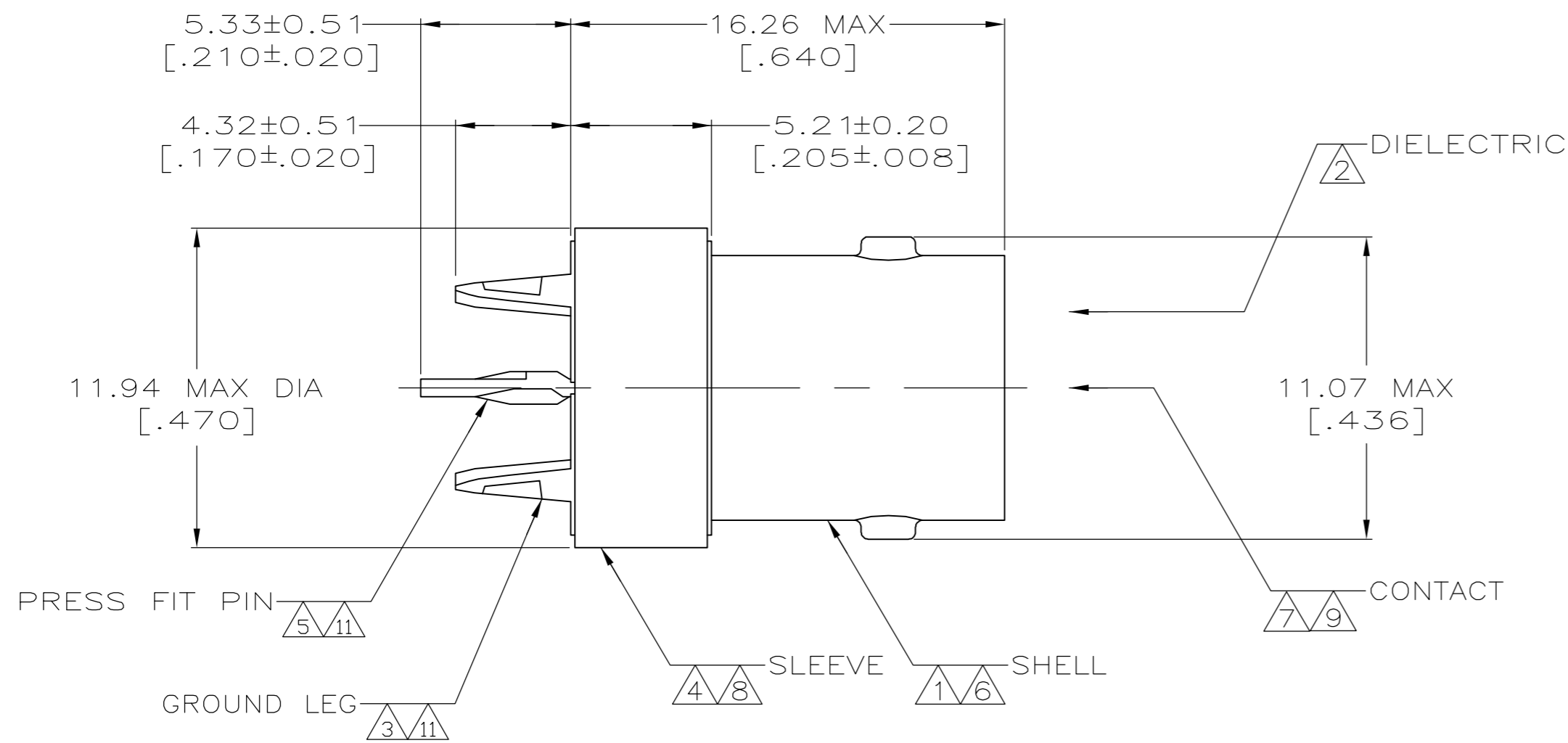

- 1 ZINC PER QQ-Z-363.
- 2 PTFE PER MIL-P-19468.
- 3 COPPER-IRON ALLOY PER ASTM-B-465.
- 4 COPPER PER QQ-C-576.
- 5 COPPER-NICKEL ALLOY PER ASTM-B-122.
- 6 NICKEL PLATE PER QQ-N-290
3.81 μm [.000150] MINIMUM THICK.
- 7 GOLD PLATE PER MIL-G-45204
0.76 μm [.000030] MINIMUM THICK.
- 8 TIN PLATE PER ASTM-B-545,
2.54 μm [.000100] MIN THICK.
- 9 BERYLLIUM COPPER PER ASTM-B-643.
- 10. INTERFACE DIMENSIONS PER LUCENT
SPEC WP-92009.
- 11 TIN-LEAD PLATE PER ASTM-B-545,
2.54 μm [.000100] MIN THICK.
- 12. CONNECTOR PRESS FIT IS DESIGNED TO PROVIDE
100 LB. MINIMUM AXIAL RETENTION TO PCB COMPLIANT
WITH TYCO APPLICATION SPEC 114-12001. AS A
RESULT, DEFORMATION OF PLATED THROUGH HOLES
WILL OCCUR. CUSTOMER VALIDATION AND ACCEPTANCE
OF THIS DEFORMATION IS RECOMMENDED PRIOR TO
SPECIFYING USE OF THIS PRODUCT.

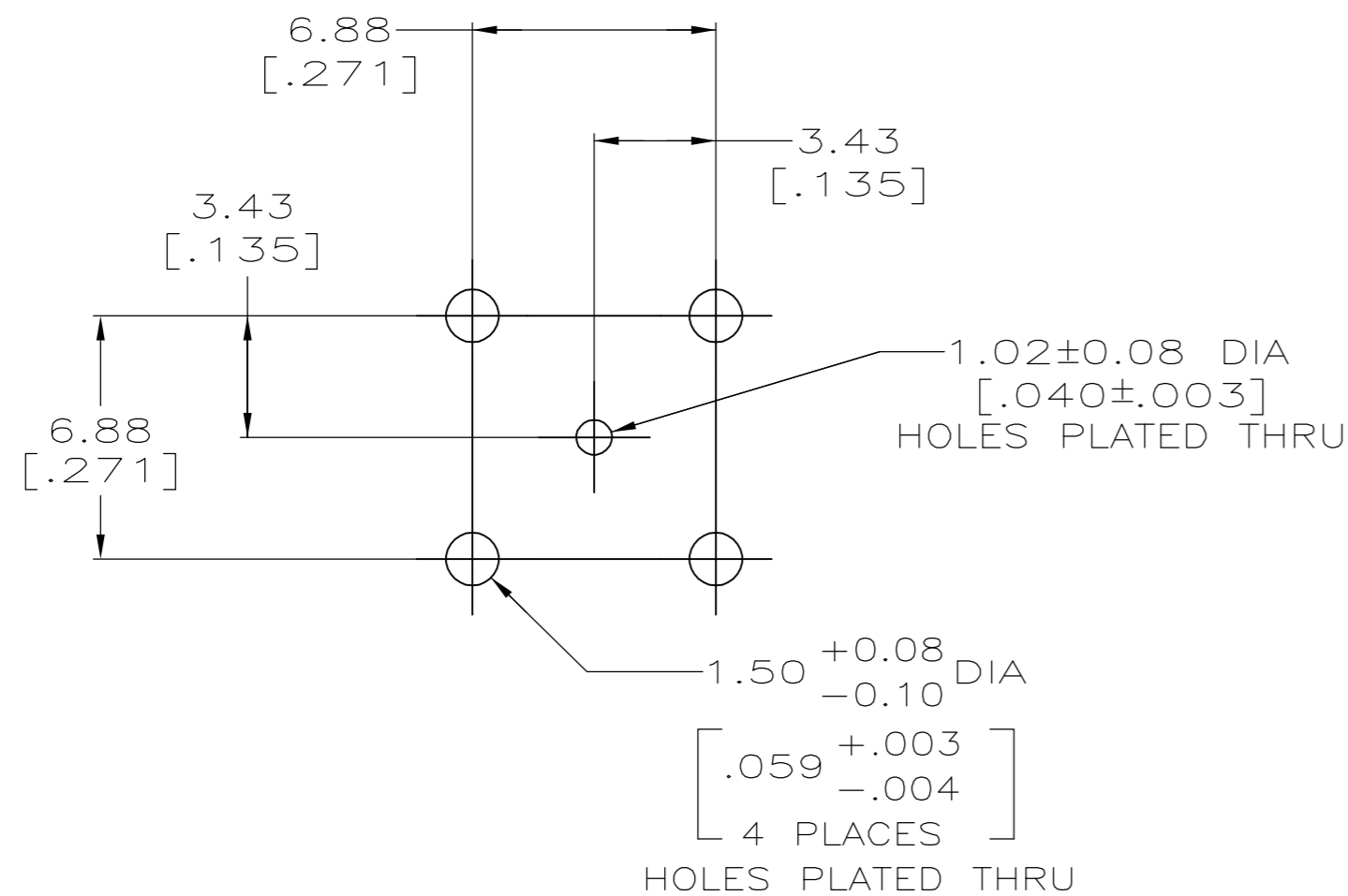

PCB CONFIGURATION

414088-1
PART NUMBER

THIS DRAWING IS A CONTROLLED DOCUMENT.		DWN J. LIPPERT 4-29-91	Tyco Electronics Corporation Harrisburg, PA 17105-3608	
DIMENSIONS: INCHES		CHK A. GABANY 5-9-91		
TOLERANCES UNLESS OTHERWISE SPECIFIED:		APVD -	NAME JACK, PCB, HIGH RETENTION PRESS FIT, 75 OHM, BNC	
0 PLC ± - 1 PLC ± - 2 PLC ± 0.05 [.002] 3 PLC ± - 4 PLC ± - ANGLES ± - FINISH		PRODUCT SPEC -	SIZE A2	CAGE CODE 00779
MATERIAL NOTES 1-5,9		APPLICATION SPEC -	DRAWING NO C=414088	RESTRICTED TO -
CUSTOMER DRAWING		WEIGHT -	SCALE 5:1	SHEET 1 of 1
		REV K		