

THIS DRAWING IS UNPUBLISHED. RELEASED FOR PUBLICATION  
 © COPYRIGHT - By - ALL RIGHTS RESERVED.

LOC		DIST		REVISIONS			
P	LTR	DESCRIPTION	DATE	DWN	APVD		
	A	PRODUCTION RELEASE PER ECO-13-014747	9-18-13	CT	RL		

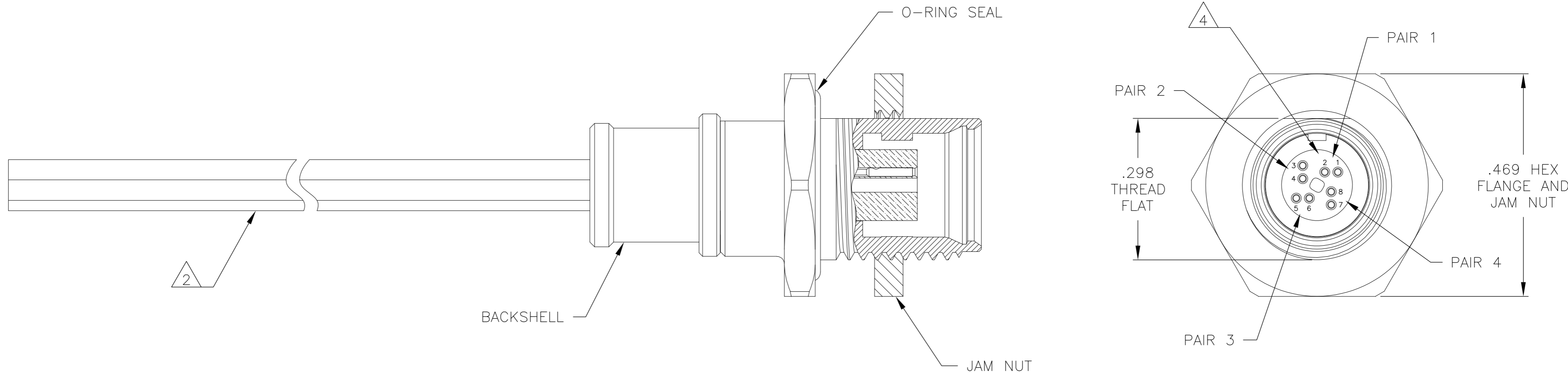
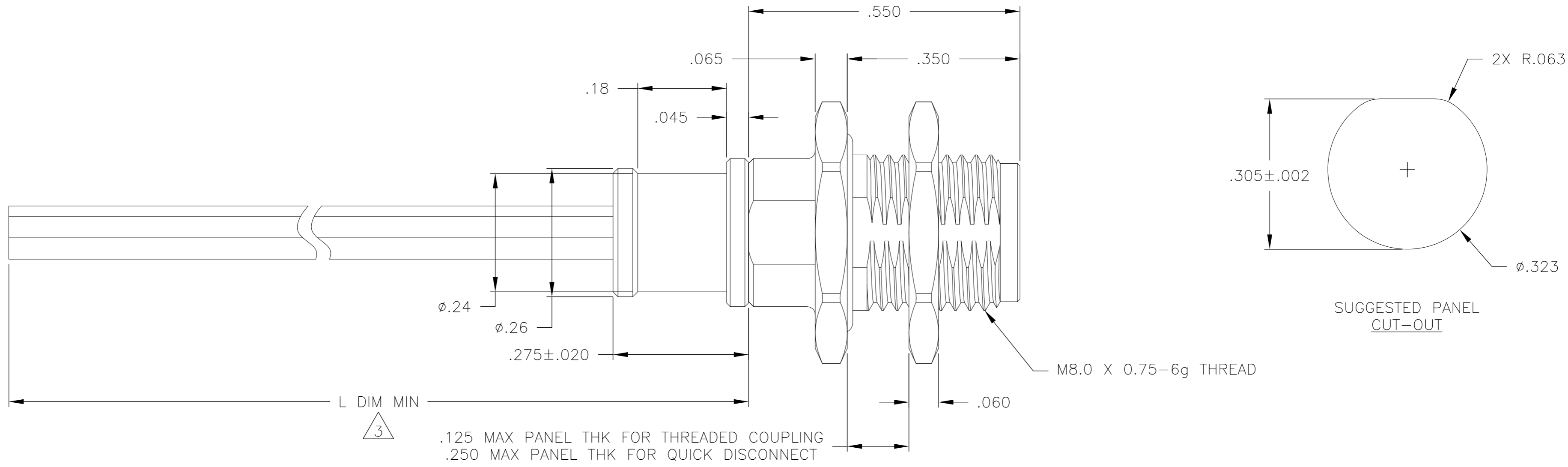

- 1 CONNECTOR BODY, JAM NUT, AND BACKSHELL MATERIAL: 6061-T6 ALUMINUM, ELECTROLESS NICKEL PLATED PER SAE-AMS-C-26074 OR SAE-AMS-2404  
INSULATOR MATERIAL: LIQUID CRYSTAL POLYMER (LCP) PER ASTM D5138  
O-RING MATERIAL: FLUOROSILICONE PER SAE-AMS-R-25988
- 2 TERMINATED WITH MADISON CABLE 30 AWG 10G TURBO TWIN PAIR
- 3 CABLE LENGTH IS AS INDICATED IN THE CORRESPONDING NANONICS PART NUMBER
- 4 CAVITY POSITIONS ARE SHOWN FOR REFERENCE ONLY AND ARE NOT MARKED ON THE PART
- 5 BONDING RESISTANCE OF CONNECTOR BODY TO BACKSHELL SHALL BE 25 MILLIOHMS MAXIMUM
- 6 LUBRICATE O-RING WITH PARKER SUPER-O-LUBE PRIOR TO INSTALLATION
- 7 REFERENCE TE PRODUCT SPECIFICATION 108-32048 FOR PRODUCT DETAILS AND PERFORMANCE

THIS DRAWING IS A CONTROLLED DOCUMENT.		DWN M STORRY 30 JUL 2012		TE Connectivity			
DIMENSIONS: INCHES		CHK M STORRY 30 JUL 2012		NAME RECEPTACLE ASSEMBLY, CIRCULAR, REAR PANEL MT, THD COUPLING/QUICK DISC, STRAIGHT BACKSHELL METAL, 8 POS, 10GbE, CeeLok FAS-T Nano Circular			
TOLERANCES UNLESS OTHERWISE SPECIFIED:		APVD M STORRY 30 JUL 2012	PRODUCT SPEC	SIZE A2	CAGE CODE 0PJN9	DRAWING NO. 1925259	RESTRICTED TO
MATERIAL SEE NOTES		FINISH SEE NOTES	APPLICATION SPEC	WEIGHT	SCALE 6:1	SHEET 1 of 1	REV A
0 PLC ± -		CUSTOMER DRAWING					
1 PLC ± -							
2 PLC ± .010							
3 PLC ± .005							
4 PLC ± -							
ANGLES ± 1°							