

- 1
- 2
- 3
- 4
- 5
- 6
- 7
- 8
- 9
- 10
- 11
- 12
- 13
- 14
- 15
- 16
- 17
- 18

MATERIAL

Glass-fibre reinforced polyamide (PA) SUPER-technopolymer body, black colour, matte finish.

ROTATING PIN

Aluminium.

Pin housing end caps made out of acetal based (POM) technopolymer, black colour.

RETURN SPRING

Stainless steel.

STANDARD EXECUTIONS

Pass-through holes for M6 cylindrical head screws.

- **CFMR-NC**: automatic return on closing.
- **CFMR-NC-LB**: automatic return on closing, for heavy doors.
- **CFMR-NO**: automatic return on opening.
- **CFMR-NO-LB**: automatic return on opening, for heavy doors.

Suffix for torque value of the return spring:

- 020: max return torque 0.20Nm, holding torque 0.07Nm.
- 035: max return torque 0.35Nm, holding torque 0.12Nm.
- 070: max return torque 0.70Nm, holding torque 0.25Nm.
- 100: max return torque 1Nm, holding torque 0.33Nm.
- **CFMR-NS**: complementary hinge, no return spring.
- **CFMR-NS-LB**: complementary hinge, without return, without spring, for heavy doors.

Thanks to optimisation of the tribological properties, the CFMR-LB versions make it possible to reduce the friction coefficient and therefore use the hinge on heavier doors.

ROTATION ANGLE (APPROXIMATE VALUE)

Max 270° (-90° and +180° being 0° the condition where the two interconnected surfaces are on the same plane).

The hinge can reach -90 ° but this condition must not be used for CFMR-NO execution.

Do not exceed the rotation limit angle so as not to prejudice the correct operation of the return spring.

FEATURES AND PERFORMANCES

CFMR hinge is used for the automatic re-closing or re-opening of the door by the return spring.

The torque varies progressively with the opening/closing angle of the hinge.

In specific fatigue stress tests, the return spring exceeded 100,000 cycles while maintaining the same unaltered torque values.



ELESA Original design

SELECTION GUIDE

The return force of a door that has a certain weight W (Kg) depends on the spring force of the hinge [Nm] and of the friction between the sliding surfaces between the fixed part and the movable part of the hinge which in turn depend on the tribological properties of the technopolymer used.

The table provides a rough guide for choosing the hinge and its positioning for a specific application.

These values are the result of tests carried out in a laboratory under controlled temperature and humidity (23°C-50% R.H.), under determined conditions of use and for a limited period of time.

It is recommended to always check the correct operation for the intended application.

For further general technical information, consult the Guidelines (see page 952).

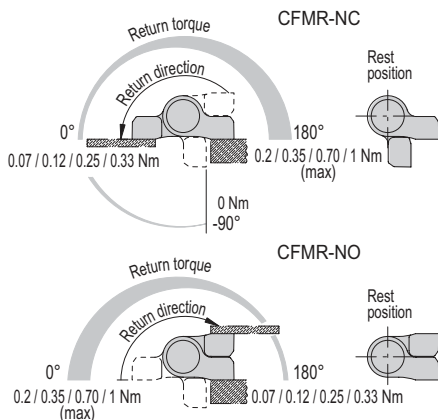
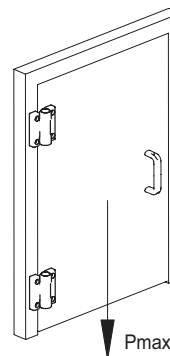

Pmax door weight	Suitable hinges
< 5 Kg	CFMR-020 + CFMR-NS
< 5 Kg	CFMR-020 + CFMR-020
< 5 Kg	CFMR-035 + CFMR-NS
5 Kg	CFMR-035 + CFMR-035
5 Kg	CFMR-070 + CFMR-NS
10 Kg	CFMR-070 + CFMR-70
35 Kg	CFMR-070-LB + CFMR-NS-LB
40 Kg	CFMR-100-LB + CFMR-NS-LB
70 Kg	CFMR-070-LB + CFMR-070-LB
90 Kg	CFMR-100-LB + CFMR-100-LB

Pmax= maximum weight of the door that the hinge is able to close with a small residual holding torque tested at a minimum opening angle of 45°. NOTE: this weight depends not only on the geometry of the door (in particular on its centre of gravity) but also on the perfect coaxiality of the hinges.

Resistance tests	Axial Stress	Radial Stress	90° Angled Stress
Description	Max limit static load Sa [N]	Max limit static load Sr [N]	Max limit static load S90 [N]
CFMR.	2100	3500	1900

The max static load is the value above which the material may break thus prejudicing the hinge functionality. Obviously, a suitable factor, according to the importance and the safety level of the specific application must be applied to this value.

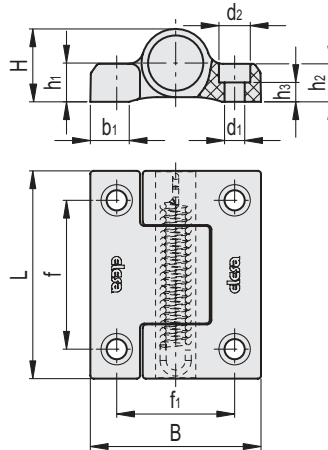

Conversion Table	
1 mm = 0.039 inch	
L	
mm	inch
67	2.61

CFMR-NC

Code	Description	L	B	d1	d2	h2	f	f1	H	h1	h3	b1	C# [Nm]	⚖
425843	CFMR.67-NC-020	67	55	6.5	10	12.5	48	38	24	12.5	6.3	12.5	6	67
425841	CFMR.67-NC-035	67	55	6.5	10	12.5	48	38	24	12.5	6.3	12.5	6	67
425845	CFMR.67-NC-070	67	55	6.5	10	12.5	48	38	24	12.5	6.3	12.5	6	67

METRIC

CFMR-NC-LB

Code	Description	L	B	d1	d2	h2	f	f1	H	h1	h3	b1	C# [Nm]	⚖
425844	CFMR.67-NC-070-LB	67	55	6.5	10	12.5	48	38	24	12.5	6.3	12.5	5	67
425847	CFMR.67-NC-100-LB	67	55	6.5	10	12.5	48	38	24	12.5	6.3	12.5	5	67

CFMR-NO

Code	Description	L	B	d1	d2	h2	f	f1	H	h1	h3	b1	C# [Nm]	⚖
425853	CFMR.67-NO-020	67	55	6.5	10	12.5	48	38	24	12.5	6.3	12.5	6	67
425852	CFMR.67-NO-035	67	55	6.5	10	12.5	48	38	24	12.5	6.3	12.5	6	67
425855	CFMR.67-NO-070	67	55	6.5	10	12.5	48	38	24	12.5	6.3	12.5	6	67

CFMR-NO-LB

Code	Description	L	B	d1	d2	h2	f	f1	H	h1	h3	b1	C# [Nm]	⚖
425854	CFMR.67-NO-070-LB	67	55	6.5	10	12.5	48	38	24	12.5	6.3	12.5	5	67
425857	CFMR.67-NO-100-LB	67	55	6.5	10	12.5	48	38	24	12.5	6.3	12.5	5	67

CFMR-NS

Code	Description	L	B	d1	d2	h2	f	f1	H	h1	h3	b1	C# [Nm]	⚖
425840	CFMR.67-NS	67	55	6.5	10	12.5	48	38	24	12.5	6.3	12.5	6	61

CFMR-NS-LB

Code	Description	L	B	d1	d2	h2	f	f1	H	h1	h3	b1	C# [Nm]	⚖
425839	CFMR.67-NS-LB	67	55	6.5	10	12.5	48	38	24	12.5	6.3	12.5	5	61

Maximum tightening torque for screw assembly.

