

APPROVAL SHEET

**LTCC Multi Layer Chip 2-WAY POWER DIVIDER
RFPDV Series – 3225(1210)-RoHS Compliance**

Halogens Free Product

950~2150 MHz Working Frequency

P/N: RFPDV3225200F0T

*Contents in this sheet are subject to change without prior notice.

FEATURES

1. Miniature footprint: 3.2 X 2.5X 2.0 mm³
2. Low Insertion Loss
3. LTCC process

APPLICATIONS

1. DC ~ 1675 MHz Working Frequency

CONSTRUCTION

Top view

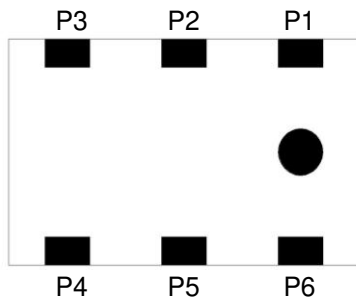

PIN	Connection	PIN	Connection
1	GND	4	Output 1
2	Input	5	GND
3	GND	6	Output 2

DIMENSIONS

Figure	Symbol	Dimension (mm)
Top view 	L	3.20 ± 0.20
	W	2.50 ± 0.20
	T	2.0 max.
Side view 	A	0.55 ± 0.15
	B	0.45 ± 0.15
	C	0.325 ± 0.10
Bottom view 	D	1.00 ± 0.20
	E	0.40 ± 0.15

ELECTRICAL CHARACTERISTICS

Item	Specification	
Frequency range	950 ~ 2150 MHz	
Insertion Loss	OUT1	4.2 dB max.
	OUT2	
Isolation	950 ~ 2150 MHz	10 dB min.
VSWR	950 ~ 1700 MHz	1.9 max.
	1700 ~ 2150 MHz	3.1 max.
Impedance	75 Ω	
Power capacity	2W max.	
Moisture sensitivity levels	MSL is LEVEL 1 (Refer to : IPC/JEDEC J-STD-020)	

Operating & Storage Condition (Component)

Operating Temperature Range: -40~ +85°C
Storage Temperature Range : -40~ +85°C

Storage Condition before Soldering (Included packaging material)

Storage Temperature Range: +5~ +40°C
Humidity: 30 to 70% relative humidity

Typical Electrical Chart

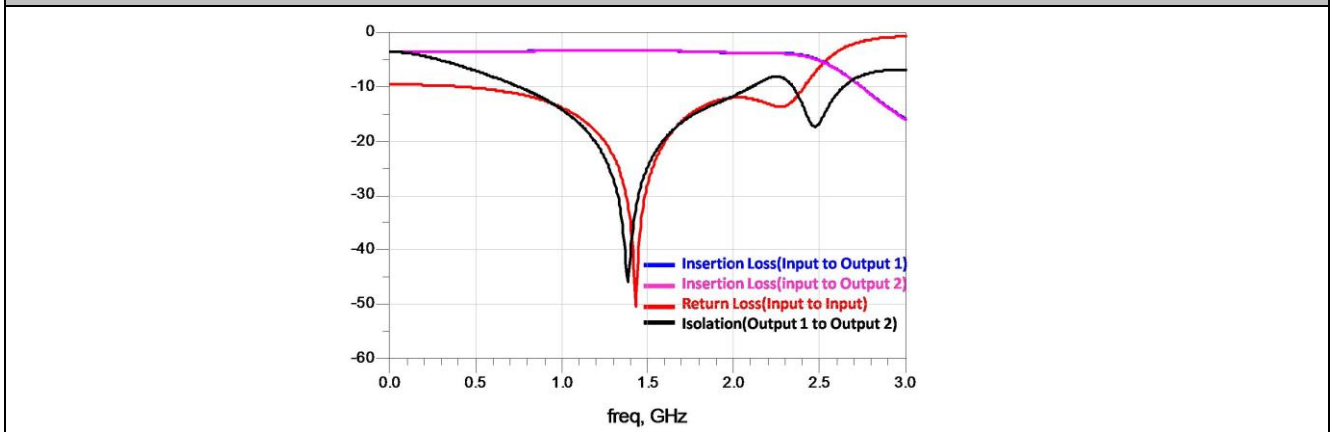

LAND PATTERN

Figure

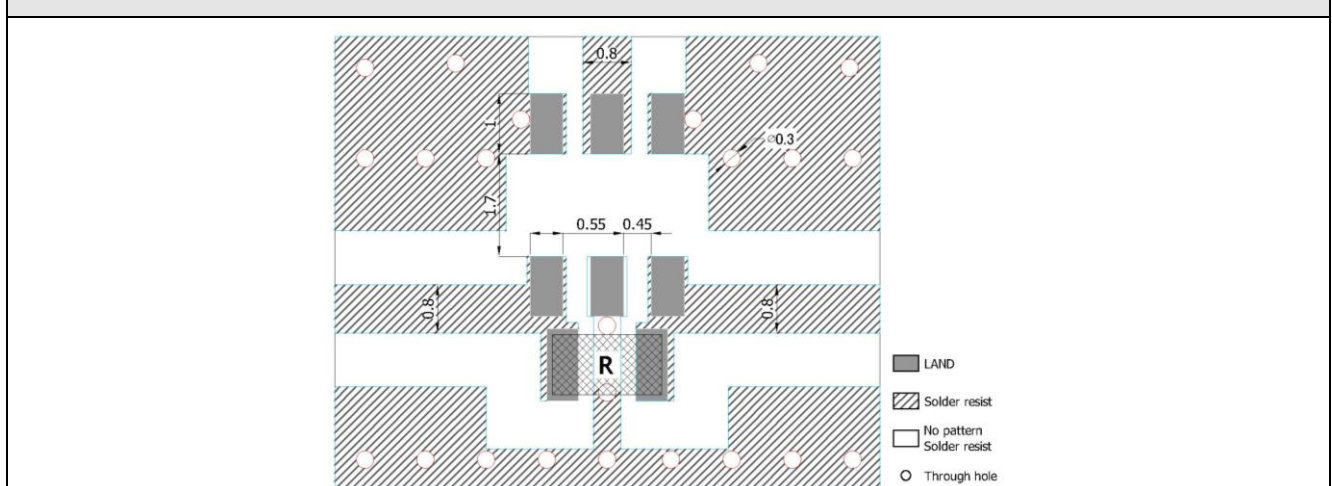

Unit : mm
Line width to be designed to match 75 Ω characteristic impedance, depending on PCB material and thickness.
In addition, since the RFPDV3225200F0T is a Wilkinson power divider, an external 0805 150Ω resistor must be mounted in locations R as shown in the Figure.

RELIABILITY TEST

Approval sheet

Test item	Test condition / Test method	Specification
Solderability JIS C 0050-4.6 JESD22-B102D	*Solder bath temperature : 235 ± 5°C *Immersion time : 2 ± 0.5 sec Solder : Sn3Ag0.5Cu for lead-free	At least 95% of a surface of each terminal electrode must be covered by fresh solder.
Resistance to soldering heat JIS C 0050-5.4	*Preheating temperature : 120~150°C, 1 minute. *Solder temperature : 270±5°C *Immersion time : 10±1 sec Solder : Sn3Ag0.5Cu for lead-free Measurement to be made after keeping at room temperature for 24±2 hrs	No mechanical damage. Electrical specification shall satisfy the descriptions in electrical characteristics under the operational temperature range within -40 ~ 85°C. Loss of metallization on the edges of each electrode shall not exceed 25%.
Drop Test JIS C 0044 Customer's specification.	*Height : 75 cm *Test Surface : Rigid surface of concrete or steel. *Times : 6 surfaces for each units ; 2 times for each side.	No mechanical damage. Electrical specification shall satisfy the descriptions in electrical characteristics under the operational temperature range within -40 ~ 85°C.
Vibration JIS C 0040	*Frequency : 10Hz~55Hz~10Hz(1min) *Total amplitude : 1.5mm *Test times : 6hrs.(Two hrs each in three mutually perpendicular directions)	No mechanical damage. Electrical specification shall satisfy the descriptions in electrical characteristics under the operational temperature range within -40 ~ 85°C.
Adhesive Strength of Termination JIS C 0051- 7.4.3	*Pressurizing force : 5N (LGA terminal series) ; 5N(≤0603) ; 10N(>0603) *Test time : 10±1 sec	No remarkable damage or removal of the termination.
Bending test JIS C 0051- 7.4.1	The middle part of substrate shall be pressurized by means of the pressurizing rod at a rate of about 1 mm/s per second until the deflection becomes 1mm/s and then pressure shall be maintained for 5±1 sec. Measurement to be made after keeping at room temperature for 24±2 hours	No mechanical damage. Electrical specification shall satisfy the descriptions in electrical characteristics under the operational temperature range within -40 ~ 85°C.

Approval sheet

<p>Temperature cycle JIS C 0025</p>	<p>1. 30±3 minutes at -40°C±3°C, 2. 10~15 minutes at room temperature, 3. 30±3 minutes at +85°C±3°C, 4. 10~15 minutes at room temperature, Total 100 continuous cycles Measurement to be made after keeping at room temperature for 24±2 hrs</p>	<p>No mechanical damage. Electrical specification shall satisfy the descriptions in electrical characteristics under the operational temperature range within -40 ~ 85°C.</p>
<p>High temperature JIS C 0021</p>	<p>*Temperature : 85°C±2°C *Test duration : 1000+24/-0 hours Measurement to be made after keeping at room temperature for 24±2 hrs</p>	<p>No mechanical damage. Electrical specification shall satisfy the descriptions in electrical characteristics under the operational temperature range within -40 ~ 85°C.</p>
<p>Humidity (steady conditions) JIS C 0022</p>	<p>*Humidity : 90% to 95% R.H. *Temperature : 40±2°C *Time : 1000+24/-0 hrs. Measurement to be made after keeping at room temperature for 24±2 hrs ※ 500hrs measuring the first data then 1000hrs data</p>	<p>No mechanical damage. Electrical specification shall satisfy the descriptions in electrical characteristics under the operational temperature range within -40 ~ 85°C.</p>
<p>Low temperature JIS C 0020</p>	<p>*Temperature : -40°C±2°C *Test duration : 1000+24/-0 hours Measurement to be made after keeping at room temperature for 24±2 hrs</p>	<p>No mechanical damage. Electrical specification shall satisfy the descriptions in electrical characteristics under the operational temperature range within -40 ~ 85°C.</p>

SOLDERING CONDITION

Typical examples of soldering processes that provide reliable joints without any damage are given in Fig 2,

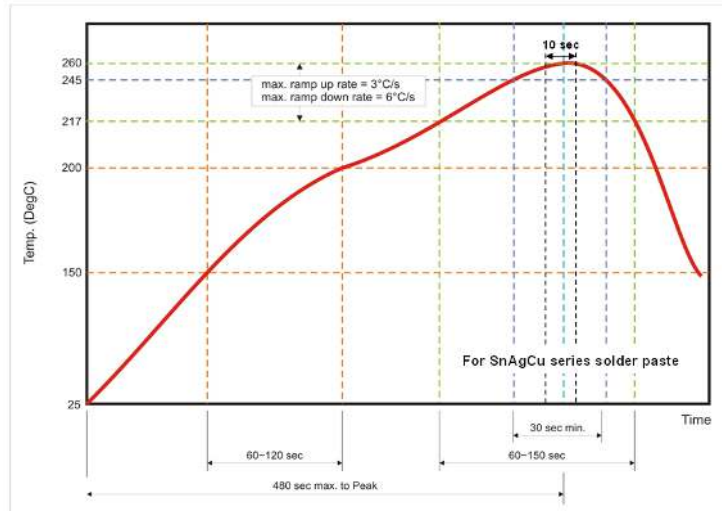

Fig 2. Infrared soldering profile

ORDERING CODE

RF	PDV	322520	0	F	0	T
Walsin RF device	Product Code PDV : Power Divider	Dimension code Per 2 digits of Length, Width, Thickness : e.g. : 322520 = Length 32, Width 25, Thickness 20	Unit of Dimension 0 : 0.1 mm 1 : 1.0 mm	Application F : W-CDMA 2100MHz	Specification Design code	Packing T : Reeled

Minimum Ordering Quantity: 2000 pcs per reel.

PACKAGING

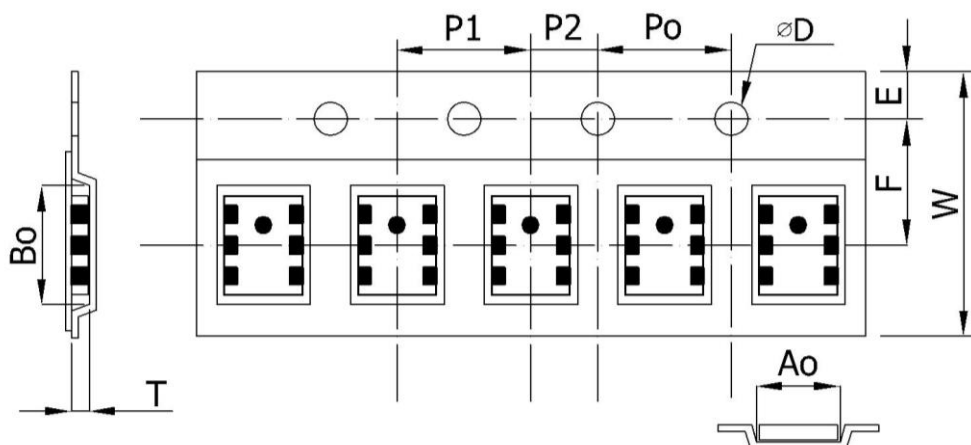

Plastic Tape specifications (unit :mm)

Index	Ao	Bo	φD	T	W
Dimension (mm)	2.72± 0.10	3.60 ±0.10	1.55 + 0.10	2.10± 0.10	8.0 ± 0.10
Index	E	F	Po	P1	P2
Dimension (mm)	1.75 ± 0.10	3.50 ± 0.05	4.00 ± 0.10	4.00 ± 0.10	2.00 ± 0.05

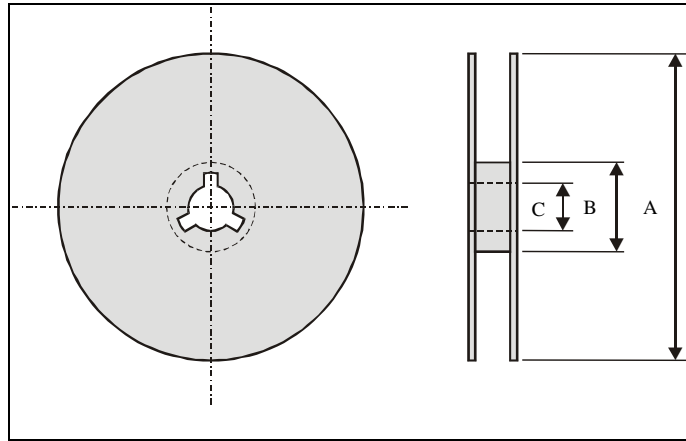
Reel dimensions

Index	A	B	C
Dimension (mm)	Φ178.0	Φ60.0	Φ13.0

Taping Quantity: 2000 pieces per 7" reel

CAUTION OF HANDLING**Limitation of Applications**

Please contact us before using our products for the applications listed below which require especially high reliability for the prevention of defects, which might directly cause damage to the third party's life, body or property.

- (1) Aircraft equipment
- (2) Aerospace equipment
- (3) Undersea equipment
- (4) Medical equipment
- (5) Disaster prevention / crime prevention equipment
- (6) Traffic signal equipment
- (7) Transportation equipment (vehicles, trains, ships, etc.)
- (8) Applications of similar complexity and /or reliability requirements to the applications listed in the above.

Storage condition

- (1) Products should be used in 6 months from the day of WALSIN outgoing inspection.
- (2) Storage environment condition.
 - Products should be storage in the warehouse on the following conditions.
 - Temperature : +5 to +40℃
 - Humidity : 30 to 70% relative humidity
 - Don't keep products in corrosive gases such as sulfur. Chlorine gas or acid or it may cause oxidization of electrode, resulting in poor solderability.
 - Products should be storage on the palette for the prevention of the influence from humidity, dust and son on.
 - Products should be storage in the warehouse without heat shock, vibration, direct sunlight and so on.
 - Products should be storage under the airtight packaged condition.