

ANSI/AAMI ES60601-1 UL62368-1 BS EN/EN60601-1 BS EN/EN62368-1 IEC60601-1 TPTC004 IEC62368-1

■ Features

- 4"×2" compact size
- Medical safety approved (2 x MOPP) according to ANSI/AAMI ES60601-1 and IEC/BS EN/EN60601-1
- Suitable for BF application with appropriate system consideration
- Cooling by free air convection
- EMI class B for class I configuration
- Extremely low leakage current
- Protections: Short circuit / Overload / Over voltage
- 3 years warranty

■ Applications

- Oral irrigator
- Hemodialysis machine
- Medical computer monitors
- Sleep apnea devices

■ GTIN CODE

MW Search: <https://www.meanwell.com/serviceGTIN.aspx>

■ Description

RPT-60 is a 60W highly reliable green PCB type medical power supply with a high power density on the 4" by 2" footprint. It accepts 90~264VAC input and offers dual output voltages .

RPT-60 is able to be used for Class I (with FG) system design. The extremely low leakage current is less than 150µA. In addition, it conforms to international medical regulations (2*MOPP) and EMC BS EN/EN55011.

■ Model Encoding

RPT - 60 A

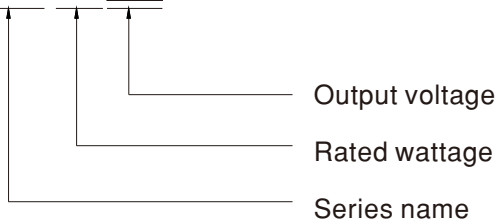



SPECIFICATION

MODEL		RPT-60A			RPT-60B			RPT-60C		
OUTPUT	OUTPUT NUMBER	CH1	CH2	CH3	CH1	CH2	CH3	CH1	CH2	CH3
	DC VOLTAGE	5V	12V	-5V	5V	12V	-12V	5V	15V	-15V
	RATED CURRENT	4A	2A	0.5A	4A	2A	0.5A	4A	1.5A	0.5A
	CURRENT RANGE	0.5 ~ 4.4A	0.1 ~ 2.2A	0.1 ~ 0.55A	0.5 ~ 4.4A	0.1 ~ 2.2A	0.1 ~ 0.55A	0.5 ~ 4.4A	0.1 ~ 1.65A	0.1 ~ 0.55A
	RATED POWER	46.5W			50W			50W		
	PEAK LOAD(10sec.) Note.2	51.15W			55W			55W		
	RIPPLE & NOISE (max.) Note.3	80mVp-p	80mVp-p	80mVp-p	80mVp-p	80mVp-p	100mVp-p	80mVp-p	100mVp-p	150mVp-p
	VOLTAGE TOLERANCE Note.4	+3,-2%	± 6.0%	+9,-8%	+3,-2%	± 6.0%	+10,-6%	+3,-2%	± 6.0%	± 8.0%
	LINE REGULATION	± 0.5%	± 1.0%	± 1.0%	± 0.5%	± 1.0%	± 2.0%	± 0.5%	± 2.0%	± 2.0%
	LOAD REGULATION	± 1.5%	± 2.0%	+5,-7%	± 1.5%	± 2.0%	± 5.0%	± 1.5%	± 3.0%	± 4.0%
	SETUP, RISE TIME	300ms, 15ms/230VAC			300ms, 15ms/115VAC at full load					
HOLD UP TIME (Typ.)	70ms/230VAC			15ms/115VAC at full load						
INPUT	VOLTAGE RANGE	90 ~ 264VAC		127 ~ 370VDC						
	FREQUENCY RANGE	47 ~ 63Hz								
	EFFICIENCY (Typ.)	77%				78%		79%		
	AC CURRENT (Typ.)	1.1A/115VAC		0.7A/230VAC						
	INRUSH CURRENT (Typ.)	COLD START 60A/230VAC		30A/115VAC						
LEAKAGE CURRENT Note.5	Earth leakage current < 150 μA/264VAC , Touch current < 100 μA/264VAC									
PROTECTION	OVERLOAD	115 ~ 150% rated output power Protection type : Hiccup mode, recovers automatically after fault condition is removed								
	OVER VOLTAGE	CH1: 5.75 ~ 6.75V Protection type : Shut down o/p voltage, re-power on to recover								
ENVIRONMENT	WORKING TEMP.	-20 ~ +65°C (Refer to "Derating Curve")								
	WORKING HUMIDITY	20 ~ 90% RH non-condensing								
	STORAGE TEMP., HUMIDITY	-40 ~ +85°C, 10 ~ 95% RH non-condensing								
	TEMP. COEFFICIENT	± 0.03%/°C (0 ~ 45°C)								
	VIBRATION	10 ~ 500Hz, 2G 10min./1cycle, period for 60min. each along X, Y, Z axes								
OPERATING ALTITUDE Note.6	3000 meters									
SAFETY & EMC (Note 8)	SAFETY STANDARDS	UL62368-1,TUV BS EN/EN62368-1,IEC62368-1,IEC60601-1, EAC TP TC 004,UL ANSI/AAMI ES60601-1, CAN/CSA-C22.2 No. 60601-1:14 - Edition 3 approved, TUV BS EN/EN60601-1 approved								
	ISOLATION LEVEL	Primary-Secondary: 2xMOPP, Primary-Earth: 1xMOPP, Secondary-Earth: 1xMOPP								
	WITHSTAND VOLTAGE	I/P-O/P:4KVAC I/P-FG:2KVAC O/P-FG:1.5KVAC								
	ISOLATION RESISTANCE	I/P-O/P, I/P-FG, O/P-FG:100M Ohms / 500VDC / 25°C / 70% RH								
	EMC EMISSION	Parameter	Standard				Test Level / Note			
		Conducted emission	BS EN/EN55011 (CISPR11)				Class B			
		Radiated emission	BS EN/EN55011 (CISPR11)				Class B			
		Harmonic current	BS EN/EN61000-3-2				Class A			
		Voltage flicker	BS EN/EN61000-3-3				-----			
	EMC IMMUNITY	BS EN/EN55035, BS EN/EN60601-1-2								
Parameter		Standard				Test Level / Note				
ESD		BS EN/EN61000-4-2				Level 4, 15KV air ; Level 4, 8KV contact				
RF field susceptibility		BS EN/EN61000-4-3				Level 3, 10V/m(80MHz~2.7GHz) Table 9, 9~28V/m(385MHz~5.78GHz)				
EFT bursts		BS EN/EN61000-4-4				Level 3, 2KV				
Surge susceptibility		BS EN/EN61000-4-5				Level 4, 4KV/Line-FG ; 2KV/Line-Line				
Conducted susceptibility		BS EN/EN61000-4-6				Level 3, 10V				
Magnetic field immunity		BS EN/EN61000-4-8				Level 4, 30A/m				
Voltage dip, interruption	BS EN/EN61000-4-11				100% dip 1 periods, 30% dip 25 periods, 100% interruptions 250 periods					
OTHERS	MTBF	4415.3K hrs min. Telcordia SR-332 (Bellcore) ; 677.8K hrs min. MIL-HDBK-217F (25°C)								
	DIMENSION (L*W*H)	101.6*50.8*29mm or 4" * 2" * 1.14" inch								
	PACKING	0.15Kg; 96pcs/15.4Kg/0.89CUFT								

NOTE

- All parameters NOT specially mentioned are measured at 230VAC input, rated load and 25°C of ambient temperature.
- 33% Duty cycle maximum within every 30 seconds. Average output power should not exceed the rated power.
- Ripple & noise are measured at 20MHz of bandwidth by using a 12" twisted pair-wire terminated with a 0.1 μf & 47 μf parallel capacitor.
- Tolerance : includes set up tolerance, line regulation and load regulation.
- Touch current was measured from primary input to DC output.
- The ambient temperature derating of 3.5°C/1000m with fanless models and of 5°C/1000m with fan models for operating altitude higher than 2000m(6500ft).
- Length of set up time is measured at cold first start. Turning ON/OFF the power supply may lead to increase of the set up time.
- Heat Sink HS1,HS2 can not be shorted.
- The power supply is considered a component which will be installed into a final equipment. All the EMC tests are been executed by mounting the unit on a 360mm*360mm metal plate with 1mm of thickness. The final equipment must be re-confirmed that it still meets EMC directives. For guidance on how to perform these EMC tests, please refer to "EMI testing of component power supplies." (as available on <http://www.meanwell.com>)

※ Product Liability Disclaimer : For detailed information, please refer to <https://www.meanwell.com/serviceDisclaimer.aspx>



SPECIFICATION

MODEL		RPT-60D			RPT-6003			
OUTPUT	OUTPUT NUMBER	CH1	CH2	CH3	CH1	CH2	CH3	
	DC VOLTAGE	5V	24V	12V	3.3V	5V	12V	
	RATED CURRENT	3.5A	1A	0.5A	5A	3A	0.7A	
	CURRENT RANGE	0.5 ~ 3.85A	0.1 ~ 1.1A	0.1 ~ 0.55A	0.5 ~ 5.5A	0.3 ~ 3.3A	0.1 ~ 0.77A	
	RATED POWER	47.5W			39.9W			
	PEAK LOAD(10sec.) Note.2	52.25W			43.89W			
	RIPPLE & NOISE (max.) Note.3	80mVp-p	150mVp-p	80mVp-p	80mVp-p	80mVp-p	80mVp-p	
	VOLTAGE TOLERANCE Note.4	+3,-2%	±6.0%	±8.0%	+3,-2%	±8.0%	+10,-6%	
	LINE REGULATION	±0.5%	±2.0%	±2.0%	±0.5%	±1.0%	±2.0%	
	LOAD REGULATION	±1.5%	±3.0%	±4.0%	±1.5%	±2.0%	+5.5,-5%	
	SETUP, RISE TIME	300ms, 15ms/230VAC 300ms, 15ms/115VAC at full load						
HOLD UP TIME (Typ.)	70ms/230VAC 15ms/115VAC at full load							
INPUT	VOLTAGE RANGE	90 ~ 264VAC 127 ~ 370VDC						
	FREQUENCY RANGE	47 ~ 63Hz						
	EFFICIENCY (Typ.)	79%			75%			
	AC CURRENT (Typ.)	1.1A/115VAC 0.7A/230VAC						
	INRUSH CURRENT (Typ.)	COLD START 60A/230VAC 30A/115VAC						
LEAKAGE CURRENT Note.5	Earth leakage current < 150 μA/264VAC , Touch current < 100 μA/264VAC							
PROTECTION	OVERLOAD	115 ~ 150% rated output power Protection type : Hiccup mode, recovers automatically after fault condition is removed						
	OVER VOLTAGE	CH1: 5.75 ~ 6.75V Protection type : Shut down o/p voltage, re-power on to recover			CH1: 3.8 ~ 4.45V			
ENVIRONMENT	WORKING TEMP.	-20 ~ +65°C (Refer to "Derating Curve")						
	WORKING HUMIDITY	20 ~ 90% RH non-condensing						
	STORAGE TEMP., HUMIDITY	-40 ~ +85°C, 10 ~ 95% RH non-condensing						
	TEMP. COEFFICIENT	±0.03%/°C (0 ~ 45°C)						
	VIBRATION	10 ~ 500Hz, 2G 10min./1cycle, period for 60min. each along X, Y, Z axes						
OPERATING ALTITUDE Note.6	3000 meters							
SAFETY & EMC (Note 9)	SAFETY STANDARDS	UL62368-1,TUV BS EN/EN62368-1,IEC62368-1,IEC60601-1, EAC TP TC 004,UL ANSI/AAMI ES60601-1, CAN/CSA-C22.2 No. 60601-1:14 - Edition 3 approved, TUV BS EN/EN60601-1 approved						
	ISOLATION LEVEL	Primary-Secondary: 2xMOPP, Primary-Earth:1xMOPP, Secondary-Earth:1xMOPP						
	WITHSTAND VOLTAGE	I/P-O/P:4KVAC I/P-FG:2KVAC O/P-FG:1.5KVAC						
	ISOLATION RESISTANCE	I/P-O/P, I/P-FG, O/P-FG:100M Ohms / 500VDC / 25°C / 70% RH						
	EMC EMISSION	Parameter	Standard			Test Level / Note		
		Conducted emission	BS EN/EN55011 (CISPR11)			Class B		
		Radiated emission	BS EN/EN55011 (CISPR11)			Class B		
		Harmonic current	BS EN/EN61000-3-2			Class A		
		Voltage flicker	BS EN/EN61000-3-3			-----		
	EMC IMMUNITY	BS EN/EN55035, BS EN/EN60601-1-2						
Parameter		Standard			Test Level / Note			
ESD		BS EN/EN61000-4-2			Level 4, 15KV air ; Level 4, 8KV contact			
RF field susceptibility		BS EN/EN61000-4-3			Level 3, 10V/m(80MHz~2.7GHz) Table 9, 9~28V/m(385MHz~5.78GHz)			
EFT bursts		BS EN/EN61000-4-4			Level 3, 2KV			
Surge susceptibility		BS EN/EN61000-4-5			Level 4, 4KV/Line-FG ; 2KV/Line-Line			
Conducted susceptibility		BS EN/EN61000-4-6			Level 3, 10V			
Magnetic field immunity		BS EN/EN61000-4-8			Level 4, 30A/m			
Voltage dip, interruption	BS EN/EN61000-4-11			100% dip 1 periods, 30% dip 25 periods, 100% interruptions 250 periods				
OTHERS	MTBF	4415.3K hrs min. Telcordia SR-332 (Bellcore) ; 677.8K hrs min. MIL-HDBK-217F (25°C)						
	DIMENSION (L*W*H)	101.6*50.8*29mm or 4" * 2" *1.14" inch						
	PACKING	0.15Kg; 96pcs/15.4Kg/0.89CUFT						

NOTE

- All parameters NOT specially mentioned are measured at 230VAC input, rated load and 25°C of ambient temperature.
- 33% Duty cycle maximum within every 30 seconds. Average output power should not exceed the rated power.
- Ripple & noise are measured at 20MHz of bandwidth by using a 12" twisted pair-wire terminated with a 0.1 μf & 47 μf parallel capacitor.
- Tolerance : includes set up tolerance, line regulation and load regulation.
- Touch current was measured from primary input to DC output.
- The ambient temperature derating of 3.5°C/1000m with fanless models and of 5°C/1000m with fan models for operating altitude higher than 2000m(6500ft).
- Length of set up time is measured at cold first start. Turning ON/OFF the power supply may lead to increase of the set up time.
- Heat Sink HS1,HS2 can not be shorted.
- The power supply is considered a component which will be installed into a final equipment. All the EMC tests are been executed by mounting the unit on a 360mm*360mm metal plate with 1mm of thickness. The final equipment must be re-confirmed that it still meets EMC directives. For guidance on how to perform these EMC tests, please refer to "EMI testing of component power supplies." (as available on <http://www.meanwell.com>)

※ Product Liability Disclaimer : For detailed information, please refer to <https://www.meanwell.com/serviceDisclaimer.aspx>

■ Block Diagram

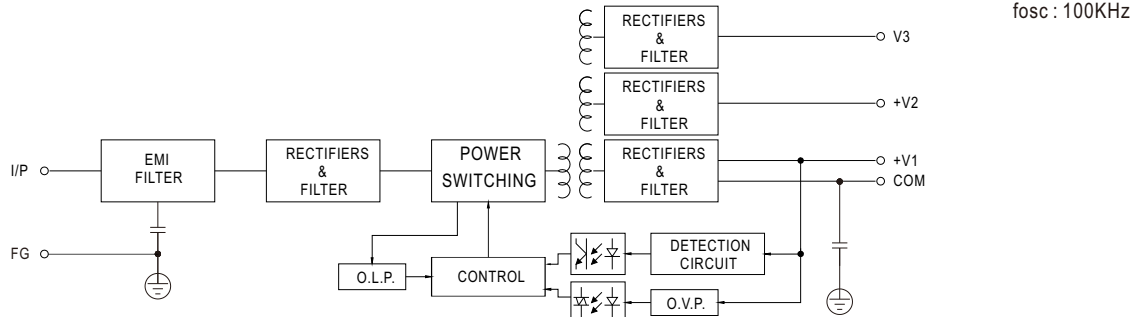

■ Derating Curve

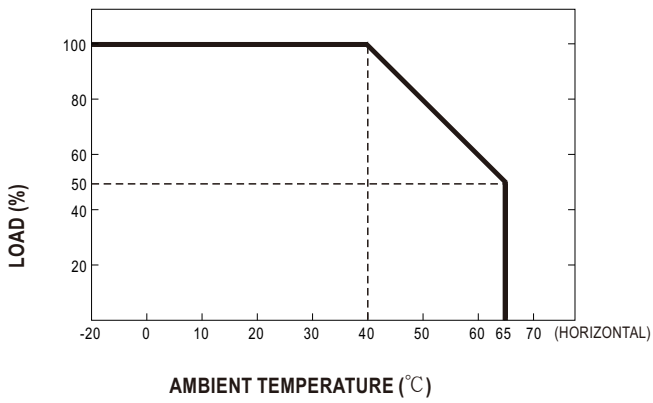

■ Output Derating VS Input Voltage

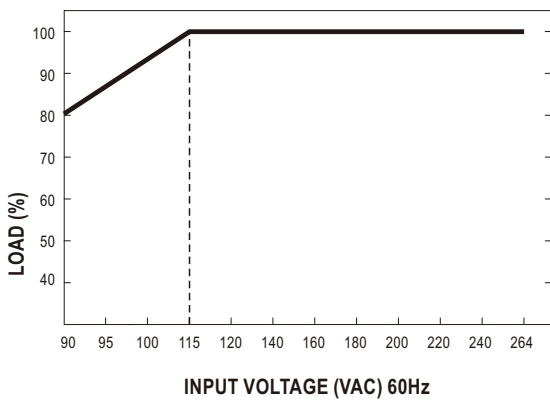

■ Mechanical Specification

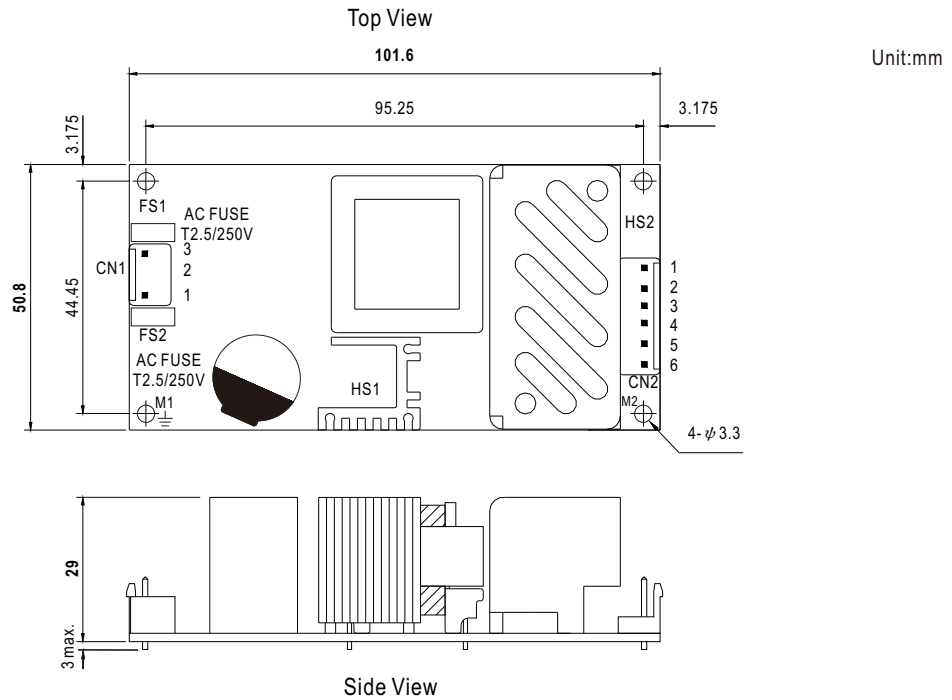

AC Input Connector (CN1) : JST B3P-VH or equivalent

Pin No.	Assignment	Mating Housing	Terminal
1	AC/N	JST VHR or equivalent	JST SVH-21T-P1.1 or equivalent
2	No Pin		
3	AC/L		

DC Output Connector (CN2) : JST B6P-VH or equivalent

Pin No.	Assignment	Mating Housing	Terminal
1,2	V1	JST VHR or equivalent	JST SVH-21T-P1.1 or equivalent
3,4	COM		
5	V2		
6	V3		

⏏ : Grounding Required

- ⚠ 1.HS1,HS2 cannot be shorted.
- 2.M1 is safety ground. For better EMC performance,
Please secure an electrical connection between
M1,M2 and chassis grounding.

■ Installation Manual

Please refer to : <http://www.meanwell.com/manual.html>