



SD100-13-23-222

Silicon Photodiode

The SD 100-13-23-222 is a 2.54mm diameter (5mm²) active area UV enhanced silicon PIN packaged in a hermetic TO-5 metal package.

Applications

Instrumentation

Industrial

Medical

Analytical Equipment

Features

Low Noise

UV Enhanced

High Shunt Resistance

High Reponse

Absolute Maximum Ratings

Parameter	Symbol	Min	Max	Unit
Reverse Voltage	V_R	-	75	V
Operating Temperature	T_{OP}	-55	+150	°C
Storage Temperature	T_{STG}	-40	+125	°C

Typical Electro-Optical Specifications at $T_A=23\text{ }^\circ\text{C}$

Parameter	Test Conditions	Symbol	Min	typ	Max	Unit
Dark Current	$V_R=5V$	I_D	-	1	6.5	nA
Shunt Resistance	$V_R=10mV$	R_{SH}	50	-	-	MΩ
Junction Capacitance	$V_R=0V$; $f=1MHz$	C_J	-	87	-	pF
	$V_R=5V$; $f=1MHz$	C_J	-	9	-	pF
Spectral Application Range	Spot Scan	λ	250	-	1100	nm
Reponsivity	$\lambda=365nm$, $V_R=0V$	R	0.14	0.18	-	A/W
Breakdown Voltage	$I = 10\text{ }\mu A$	V_{BD}	30	50	-	V
Noise Equivalent Power	$V_R=0V$ @ $\lambda=peak$	NEP	-	9×10^{-14}	-	W/√Hz
Response Time (10% to 90%)	$RL=50\Omega$, $V_R=0V$	T_R	-	75	-	nS
	$RL=50\Omega$, $V_R=5V$	T_R	-	5	-	nS

Spectral Response

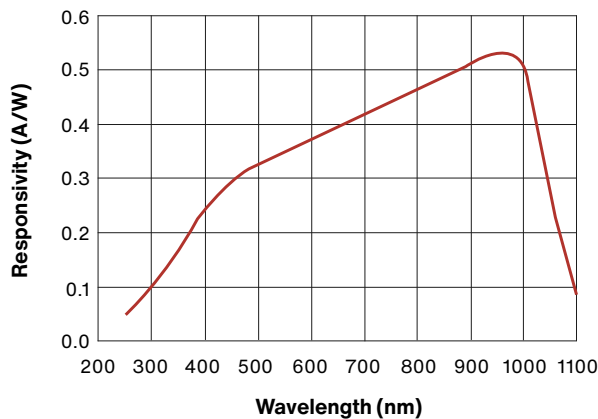

Mechanical Specifications

Units are in mm

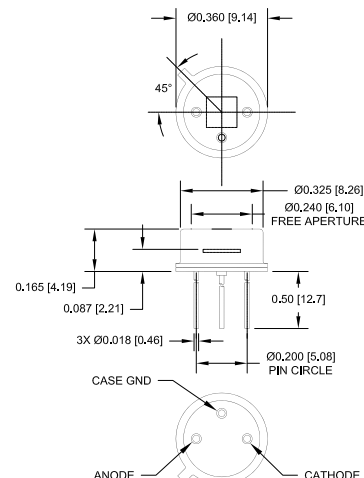

Care and handling instructions

Your optoelectronic components are packaged and shipped in opaque, padded containers to avoid ambient light exposure and damage due to shock from dropping or jarring.

Care must be taken to avoid exposure to high ambient light levels, particularly from tungsten sources or sunlight.

- These components can be rendered inoperable if dropped or sharply jarred. The wire bonds are delicate and can become separated from the bonding pads when the component is dropped or otherwise receives a sharp physical blow.
- Most windows on photodiodes are either silicon or quartz. They should be cleaned with isopropyl alcohol and a soft (optical grade) pad.
- Photodiode exposure to extreme high or low storage temperatures can affect the subsequent performance. Maintain a non-condensing environment for optimum performance and lifetime.
- All devices are considered ESD sensitive. The photodiodes are shipped in ESD protective packaging. When unpacking and using these products, anti-ESD precautions should be observed.
- Photodiode packages and/or operation may be impaired if exposed to CHLOROETHENE, THINNER, ACETONE, TRICHLOROETHYLENE or any harsh chemicals.
- Optoelectronic components in plastic packages should be given special care. Clear plastic packages are more sensitive to environmental stress than those of black plastic. Storing devices in high humidity can present problems when soldering. Since the rapid heating during soldering stresses the wire bonds and can cause wire to bonding pad separation, it is recommended that devices in plastic packages to be baked for 24 hours at 85°C.
- The leads on the photodiode SHOULD NOT BE FORMED. If your application requires lead spacing modification, please contact Advanced Photonix Applications group at Techsupport@advancedphotonix.com before forming a product's leads. Product warranties could be voided.
- Most devices are provided with wire or pin leads for installation in circuit boards or sockets. Observe the soldering temperatures and conditions specified below:
 - Soldering Iron: Soldering 30 W or less
 - Temperature at tip of iron 300°C or lower.
 - Dip Soldering: Bath Temperature: 260±5°C.
 - Immersion Time: within 5 Sec.
 - Soldering Time: within 3 Sec.
 - Vapor Phase Soldering, Reflow Soldering: DO NOT USE

Legal Disclaimer

Information in this data sheet is believed to be correct and reliable. However, no responsibility is assumed for possible inaccuracies or omission. Specifications are subject to change without notice.



Most of our standard catalog products are RoHS Compliant. Please contact us for details.

