

**60**mm sq.

# San Ace 60

15mm thick, 20mm thick, 25mm thick  
 External thermistor model /  
 Built-in thermistor model



Note: Optional external thermistors are sold separately.

## General Specifications

- Material ..... Frame: Plastics (Flammability: UL94V-0), Impeller: Plastics (Flammability: UL94V-1)
- Life Expectancy ..... Varies for each model (L10: Survival rate: 90% at 60°C, rated voltage, and continuously run in a free air state)
- Lead Wire ..... ⊕red ⊖black (Control) brown (Only for external thermistor type)
- Fail-safe ..... The motor becomes high speed when the thermistor is unable to detect the temperature in case of open or short circuit etc. (Models equipped with a pulse sensor are excluded.)
- Storage Temperature... -30°C to +70°C (Non-condensing)

**60×60×20**mm [Mass : 90g]

## Specifications External thermistor model

Model No.	Rated Voltage [V]	Operating Voltage Range [V]	Rated Current [A]	Rated Input [W]	Rated Speed [min <sup>-1</sup> ]	Air Flow [m <sup>3</sup> /min] [CFM]	Static Pressure [Pa] [inchH <sub>2</sub> O]	SPL [dB(A)]	Operating Temperature [°C]	Life Expectancy [h]
109P0612T6H12	12	10.2 to 13.8	0.15	1.8	4,200	0.42 14.8	31.9 0.128	31	-10 to +70	60,000
			0.10	1.2	2,100	0.21 7.4	8.8 0.035	21		

Note: The top row gives characteristics shown when the thermistor temperature is 35°C, while the bottom row gives characteristics shown when the thermistor temperature is 28°C (Thermistor: 169-002).

## Built-in thermistor model

Model No.	Rated Voltage [V]	Operating Voltage Range [V]	Rated Current [A]	Rated Input [W]	Rated Speed [min <sup>-1</sup> ]	Air Flow [m <sup>3</sup> /min] [CFM]	Static Pressure [Pa] [inchH <sub>2</sub> O]	SPL [dB(A)]	Operating Temperature [°C]	Life Expectancy [h]
109P0612T6H122	12	10.2 to 13.8	0.15	1.8	4,400	0.44 15.5	35.0 0.141	33	-10 to +70	60,000
			0.10	1.2	2,150	0.22 7.8	9.2 0.037	21		

Note: The top row gives characteristics shown when the temperature is 40°C, while the bottom row gives characteristics shown when the temperature is 30°C.

## Dimensions (Unit : mm)

## Reference dimensions of mounting holes and vent opening (Unit : mm)

External thermistor model

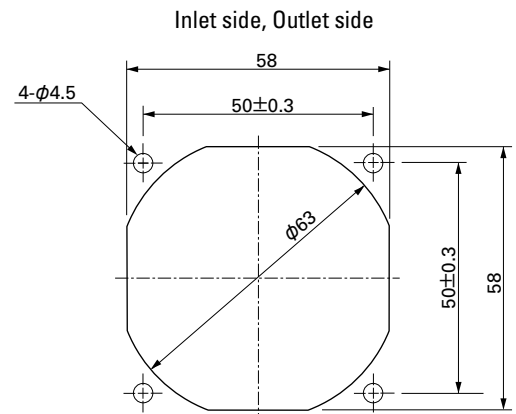
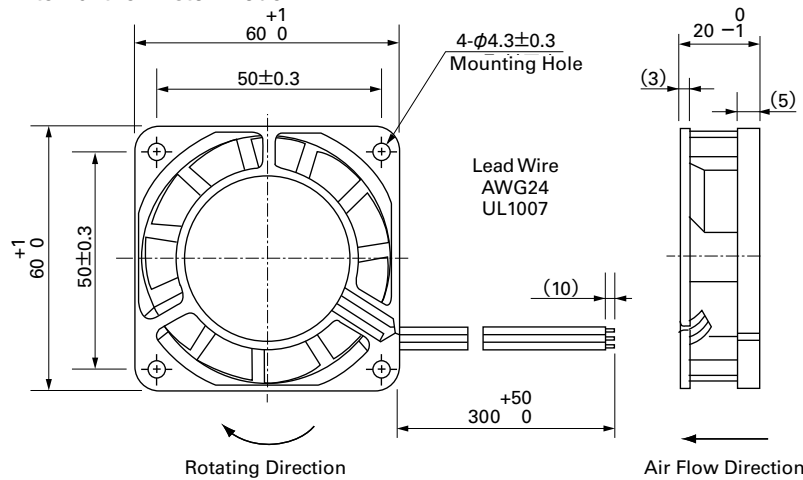

Built-in thermistor model

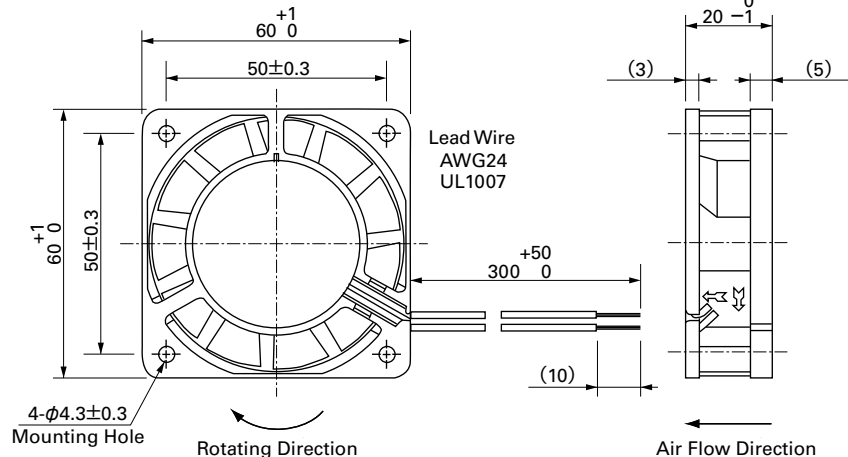

## Options (Unit : mm)

### Finger guards

Model : 109-139E Surface treatment : Nickel-chrome plating (silver)  
Color : Cation electropainting (black)

Inlet side, Outlet side

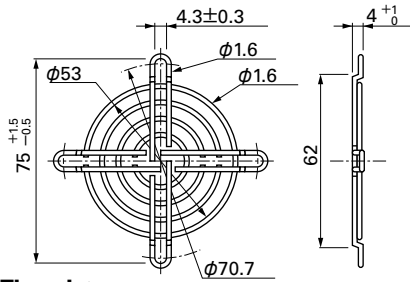

### Resin finger guards

Model : 109-1003G

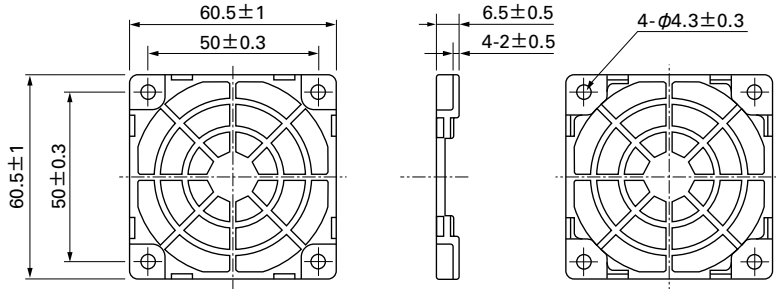

### Thermistor

Model : 169-002

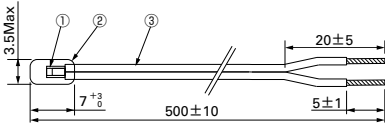

Number	Name	Standards, materials, etc.
①	Thermistor	Chip
②	Insulated cord	Epoxy resin
③	Lead	UL2555 CSA TR-64 AWG#28 (blue)

Item	Spec
2-1	Resistance R25 6.8KΩ ±3%
2-2	B constant B25/50 3950K ±2%
2-3	Maximum rated power 188mW (25°C under still air)
2-4	Insulation resistance 100MΩ or more (DC500V megger)
2-5	Dielectric strength No problem (AC1500V 1 minute)
2-6	Operating temperature range -30°C to +80°C
2-7	Storage temperature range -40°C to +100°C

Manufactured by OHIZUMI MFG CO.,LTD.

Mfr. Part No. 159-682-86 □□□

### Resin filter kits

Model : 109-1003F13 (13PPI), 109-1003F20 (20PPI)  
: 109-1003F30 (30PPI), 109-1003F40 (40PPI)

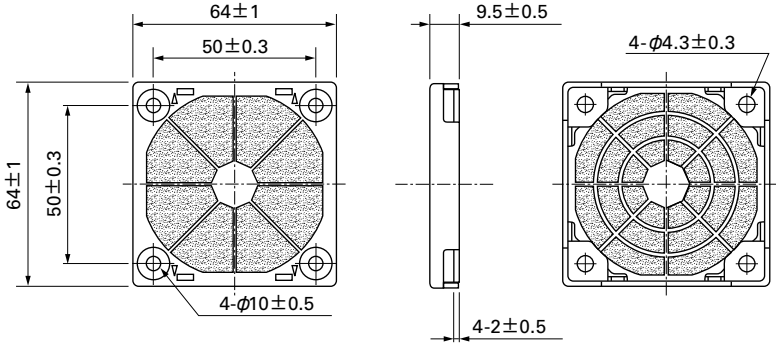

Thermal Speed Controlled Fan 60mm

## Air Flow and Static Pressure Characteristics

External thermistor model

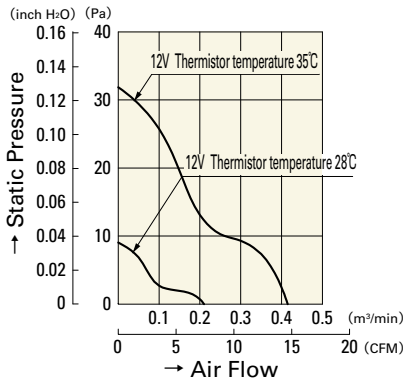

109P0612T6H12

Built-in thermistor model

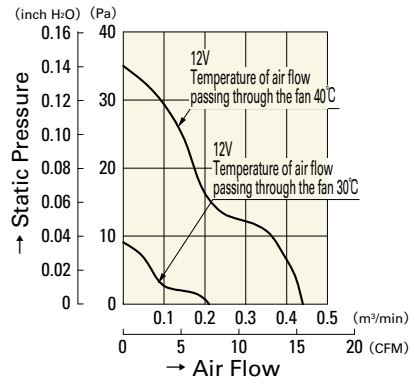

109P0612T6H122

## Temperature-Rotation Speed Characteristics

External thermistor model

■ Characteristics of Thermistor-detected Temperature vs Speed

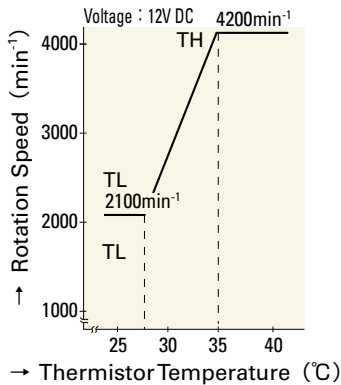

109P0612T6H12

Built-in thermistor model

■ Typical characteristics of temperature of air flowing through the fan versus rotation speed

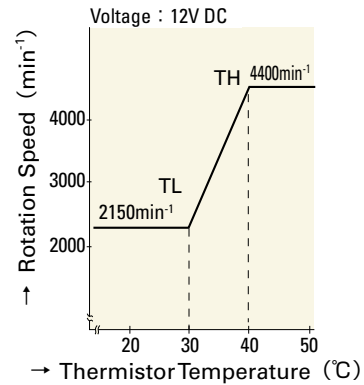

109P0612T6H122

60mm