

# SR CONNECTOR

Disconnectable insulation displacement connectors

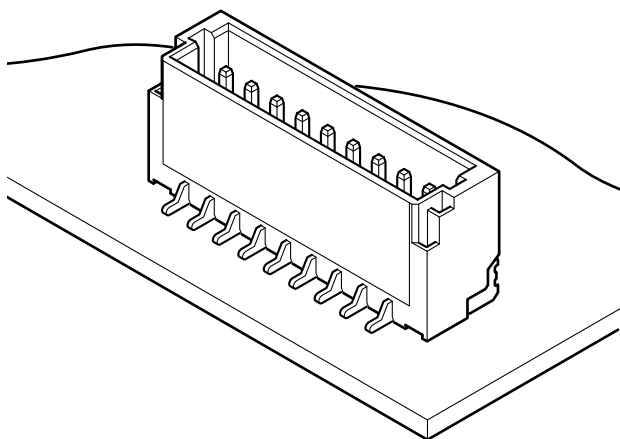
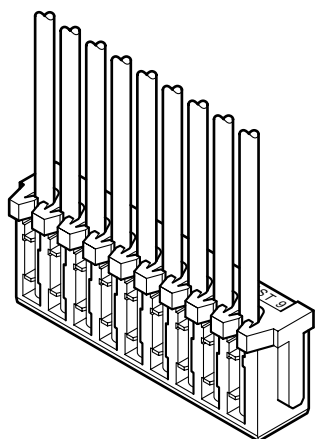
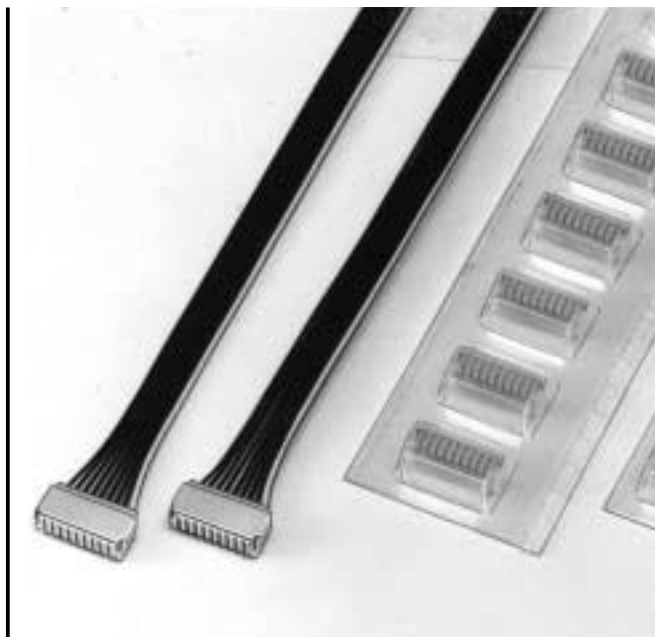

## Features

### • Ultra-compact insulation displacement connector

1.0mm (.039") pitch and only 3.0mm (.118") high (side entry type). This connector is only about 61% as large as the smallest conventional (JST) IDC designs.

### • Header designed for vacuum pick and place robotics

Although this shrouded header has locking features for its mating receptacle, there are no holes in the header shroud that would adversely effect vacuum gripping equipment. Since there is enough flat surface for secure vacuum gripping, this miniature surface mount connector is versatile for designers and economic for manufacturing.

### • Twin U-slot insulation displacement section

The insulation displacement section connected to each wire consists of two tin-plated slots (twin U-slots), which ensures reliable connection.

### • 3-point grip construction

The 3-point insulation grip feature and the strain relief ensure a firm grip on terminated wires and protection of the insulation displacement connection from possible damage.

## Specifications

- Current rating: 0.7A DC
- Voltage rating: 50V DC
- Temperature range: -25°C to +85°C (including temperature rise in applying electrical current)
- Contact resistance: Initial value/20m Ω max.  
After environmental testing/40m Ω max.
- Insulation resistance: 100M Ω min.
- Withstanding voltage: 500V AC/minute
- Applicable wire: AWG #30  
Conductor/7 strands,  
tin-coated annealed copper  
Insulation O.D./0.56mm (.022")

\* Contact JST for details.

## Standards

- 0 Recognized E60389
- 1 Certified LR20812

# SR CONNECTOR

## Receptacle

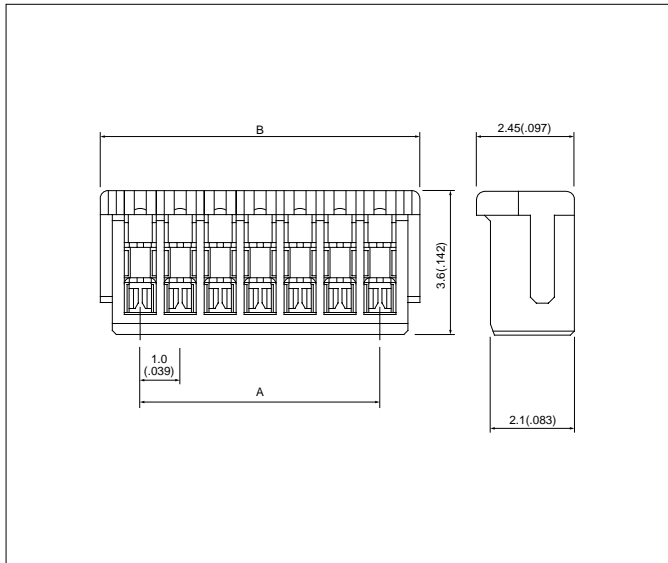

Circuits	Model No.	Dimensions mm(in.)		Q'ty / box
		A	B	
2	<b>02SR-3S</b>	1.0(.039)	3.0(.118)	3,000
3	<b>03SR-3S</b>	2.0(.079)	4.0(.157)	3,000
4	<b>04SR-3S</b>	3.0(.118)	5.0(.197)	3,000
5	<b>05SR-3S</b>	4.0(.157)	6.0(.236)	2,000
6	<b>06SR-3S</b>	5.0(.197)	7.0(.276)	2,000
7	<b>07SR-3S</b>	6.0(.236)	8.0(.315)	2,000
8	<b>08SR-3S</b>	7.0(.276)	9.0(.354)	2,000
9	<b>09SR-3S</b>	8.0(.315)	10.0(.394)	2,000
10	<b>10SR-3S</b>	9.0(.354)	11.0(.433)	2,000
11	<b>11SR-3S</b>	10.0(.394)	12.0(.472)	2,000
12	<b>12SR-3S</b>	11.0(.433)	13.0(.512)	2,000
13	<b>13SR-3S</b>	12.0(.472)	14.0(.551)	2,000
14	<b>14SR-3S</b>	13.0(.512)	15.0(.591)	2,000

### Material and Finish

Contact: Phosphor bronze, tin-plated  
Housing: Polyamide 66, UL94V-0, natural (ivory)

## Shrouded header

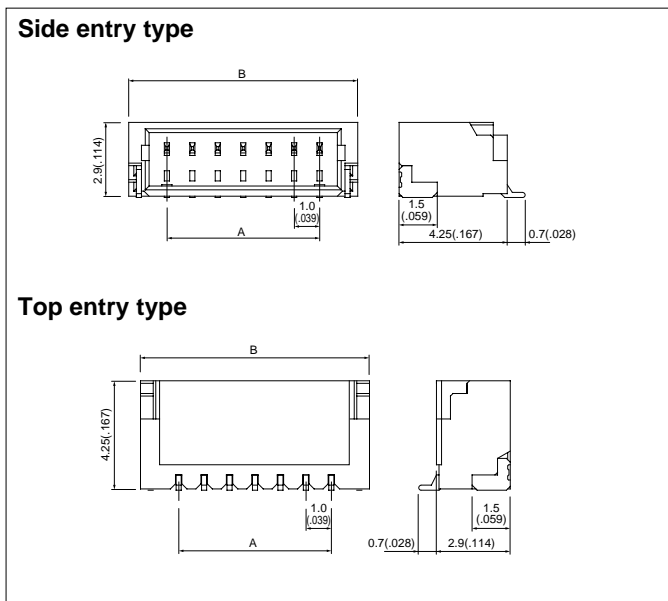

Circuits	Top entry type	Side entry type	Dimensions mm(in.)		Q'ty / reel	
			A	B	Top entry type	Side entry type
2	<b>BM02B-SRSS-TB</b>	<b>SM02B-SRSS-TB</b>	1.0(.039)	4.0(.157)	1,500	3,000
3	<b>BM03B-SRSS-TB</b>	<b>SM03B-SRSS-TB</b>	2.0(.079)	5.0(.197)	1,500	3,000
4	<b>BM04B-SRSS-TB</b>	<b>SM04B-SRSS-TB</b>	3.0(.118)	6.0(.236)	1,500	3,000
5	<b>BM05B-SRSS-TB</b>	<b>SM05B-SRSS-TB</b>	4.0(.157)	7.0(.276)	1,500	3,000
6	<b>BM06B-SRSS-TB</b>	<b>SM06B-SRSS-TB</b>	5.0(.197)	8.0(.315)	1,500	3,000
7	<b>BM07B-SRSS-TB</b>	<b>SM07B-SRSS-TB</b>	6.0(.236)	9.0(.354)	1,500	3,000
8	<b>BM08B-SRSS-TB</b>	<b>SM08B-SRSS-TB</b>	7.0(.276)	10.0(.394)	1,500	3,000
9	<b>BM09B-SRSS-TB</b>	<b>SM09B-SRSS-TB</b>	8.0(.315)	11.0(.433)	1,500	3,000
10	<b>BM10B-SRSS-TB</b>	<b>SM10B-SRSS-TB</b>	9.0(.354)	12.0(.472)	1,500	3,000
11	<b>BM11B-SRSS-TB</b>	<b>SM11B-SRSS-TB</b>	10.0(.394)	13.0(.512)	1,500	3,000
12	<b>BM12B-SRSS-TB</b>	<b>SM12B-SRSS-TB</b>	11.0(.433)	14.0(.551)	1,500	3,000
13	<b>BM13B-SRSS-TB</b>	<b>SM13B-SRSS-TB</b>	12.0(.472)	15.0(.591)	1,500	3,000
14	<b>BM14B-SRSS-TB</b>	<b>SM14B-SRSS-TB</b>	13.0(.512)	16.0(.630)	1,500	3,000

### Material and Finish

Contact: Copper alloy, copper-undercoated, tin/lead plated  
Wafer: Polyamide, UL94V-0, natural (ivory)  
Solder tab: Brass, copper-undercoated, tin/lead plated

- Note: 1. The products listed above are supplied on embossed-tape.  
2. Contact JST for the top entry type headers with suction cap.

## PC board layout (viewed from component side) and Assembly layout

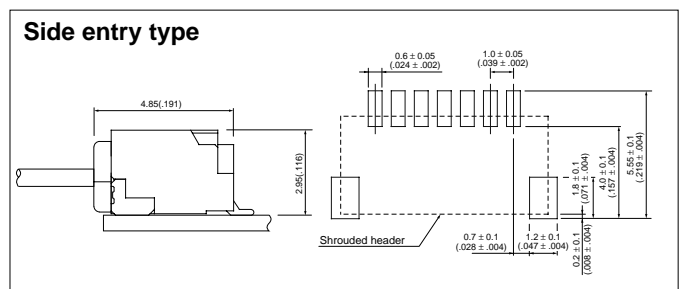
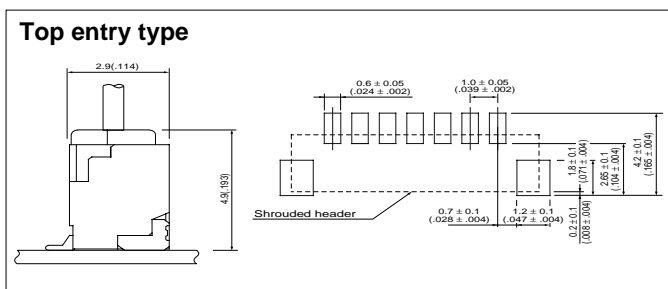

- Note: 1. Tolerances are non-cumulative:  $\pm 0.05\text{mm} (\pm .002")$  for all centers.  
2. Dimensions above should serve as a guideline. Contact JST for details.

## Taping specifications

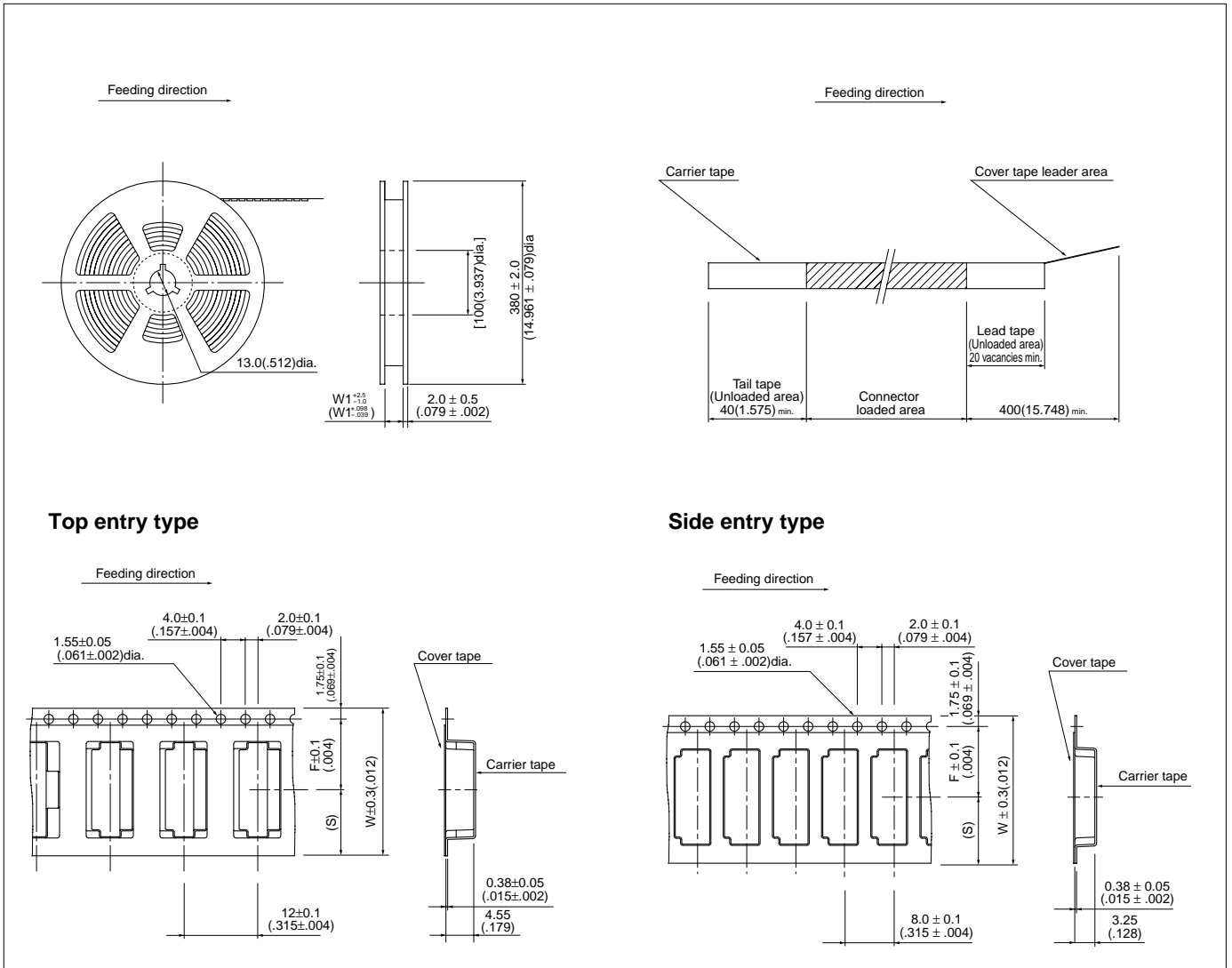

Circuits	Taping dimensions mm(in.)						Reel dimensions mm(in.)		Q'ty / reel	
	F		S		W		W1		Top entry type	Side entry type
	Top entry type	Side entry type	Top entry type	Side entry type	Top entry type	Side entry type	Top entry type	Side entry type		
2 to 3	5.5(.217)	5.5(.217)	4.75(.187)	4.75(.187)	12(.472)	12(.472)	13.5(.531)	13.5(.531)	1,500	3,000
4	7.5(.295)	5.5(.217)	6.75(.266)	4.75(.187)	16(.630)	12(.472)	17.5(.689)	13.5(.531)	1,500	3,000
5 to 7	7.5(.295)	7.5(.295)	6.75(.266)	6.75(.266)	16(.630)	16(.630)	17.5(.689)	17.5(.689)	1,500	3,000
8	11.5(.453)	7.5(.295)	10.75(.423)	6.75(.266)	24(.945)	16(.630)	25.5(1.004)	17.5(.689)	1,500	3,000
9 to 14	11.5(.453)	11.5(.453)	10.75(.423)	10.75(.423)	24(.945)	24(.945)	25.5(1.004)	25.5(1.004)	1,500	3,000

**Note:**

- Specifications conform to JIS C 0806. The tape width, connector recess hole dimensions, etc. are determined by the number of circuits and external shape of the connector to be loaded.
- Specifications are subject to change without prior notice.