

DIMENSIONING AND TOLERANCING PER ASME Y14.5M (ISO STANDARDS).
 THIS DRAWING IS A CONTROLLED DOCUMENT.

PART NUMBER	REV	FIRST USED
680592 -1	B	122500-1
680592 -2	B	565435-5

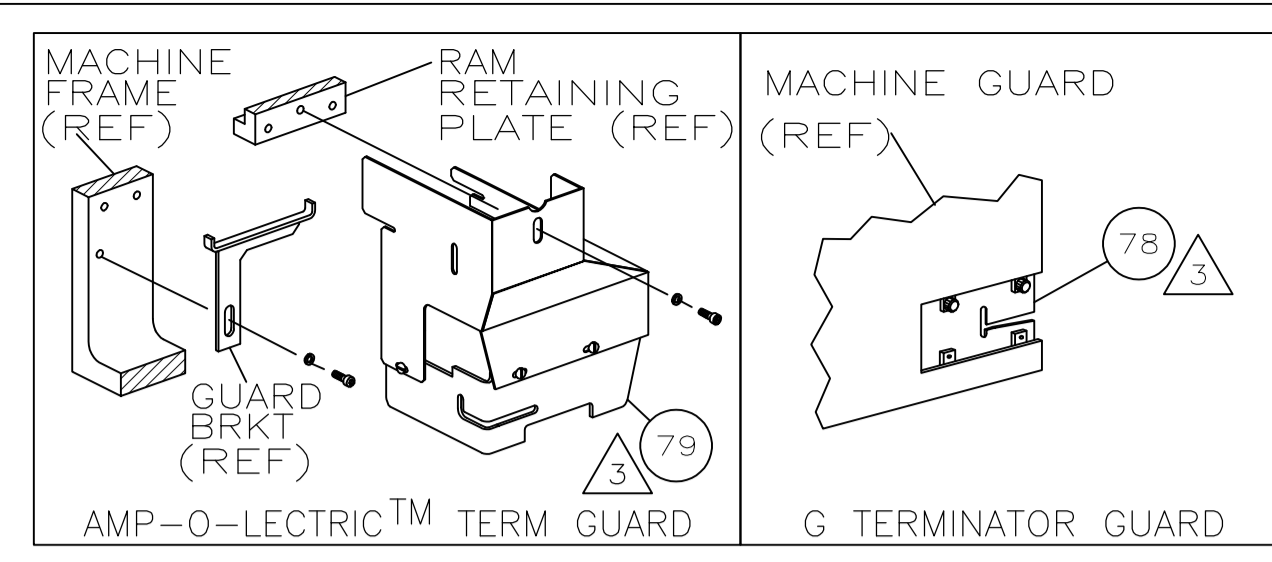

TERMINAL NAME: RING			
286691	CRIMP DATA (NON-AMP TERMINAL-AMP SPEC)		
PAD LTR	CRIMP HEIGHT	WIRE SIZE	
A	.136 ±.002 [3.45 ±0.05mm]	10	
B	.129 ±.002 [3.28 ±0.05mm]	(2) 14	
C	.124 ±.002 [3.15 ±0.05mm]	12	
D	NOT	USED	
CRIMP SIZE	TYPE	RANGE	
WIRE .220 [5.59mm]	F	12-10 or (2)14	
INSUL .340 [8.64mm]	F	Ø.148-.208	
WIRE STRIP LENGTH .297-.328	TERM APPL SPEC NONE	FEED 1.574	APPL INSTRUCTION 408-8039
		SET UP GAGE LAYOUT 458638-1	L2045

QTY	DESCRIPTION	ITEM NO
-1	LEADMAKER & BENCH MODEL G	AIR FEED
-2	BENCH MODEL K	AIR FEED

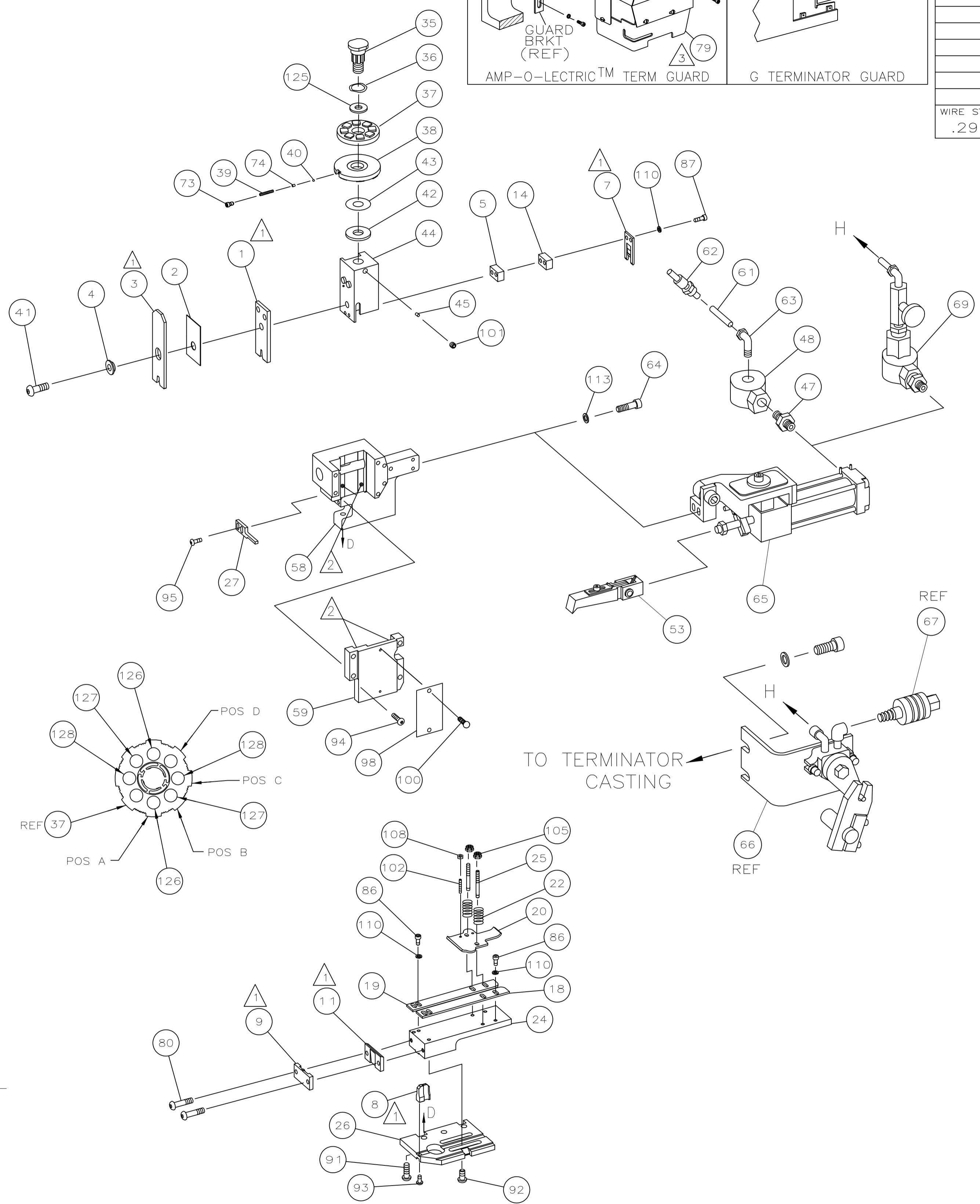

129					
2	2	-	6-354778-7	PIN, WIRE DISC (.2830)C	128
2	2	-	5-354778-6	PIN, WIRE DISC (.2775)B	127
2	2	-	4-354778-2	PIN, WIRE DISC (.2705)A	126
1	1	-	986950-1	WASHER, FLAT PRECISION	125
1	1	-	217238-1	GENERAL INSTRUCTION PACKAGE	124
1	1	-	4088039	EF APPL INST 408-8039	123
					122
					121
					120
					119
					118
					117
					116
					115
					114
2	2	-	21024-5	WASHER, LOCK(#10)AIR ASSY	113
					112
					111
4	4	-	21024-4	WASHER, LOCK(NO.8)SHEAR BL	110
					109
2	2	-	21018-4	NUT, HEX(4-40)DRAG	108
					107
					106
2	2	-	21022-2	NUT, HEX SL(8-32)DRAG STUD	105
					104
					103
2	2	-	2-21006-6	SCR, SKT SET(4-40x.62)DRAG	102
1	1	-	21009-2	SCR, SKT SET(1/4-20x.25)RAM	101
2	2	-	21017-2	SCR, DRIVE(#2x.19)ID PLATE	100
					99
1	1	-	461264-1	PLATE, IDENTIFICATION	98
					97
					96
2	2	-	2-21002-2	SCR, BHC(8-32x.50)STRIPPER	95
4	4	-	2-21002-9	SCR, BHC(10-32x.75)CAP	94
1	1	-	22733-8	SCR, BHC(8-32x.38 LW)ANVIL	93
4	4	-	3-21002-3	SCR, BHC(1/4-20x.50)ST GD PL	92
3	3	-	2-22733-8	SCR, BHC(1/4-20x.62)HSG	91
					90
					89
					88
2	2	-	8-21002-9	SCR, BHC(8-32x1.00)SLUG BLADE	87
4	4	-	2-21000-6	SCR, SHC(8-32x.38)STRIP GUIDE	86
					85
					84
					83
					82
					81
2	2	-	3-21002-0	SCR, BHC(10-32x.88)SHEAR PL	80
1	-	-	455750-7	GUARD ASSY	79
-	REF	-	679532-1	INSERT, GUARD	78
					77
					76
					75
1	1	-	690603-1	SPRING, ASSIST	74
1	1	-	23030-1	SCR, SKT CAP(6-32x.25)CP DSC	73
					72
					71

QTY	DESCRIPTION	ITEM NO				
4	1	-	692655-5	AIR FEED VALVE ASSY	70	
					69	
					68	
REF	-	-	24042-2	VALVE, SHUT OFF	67	
REF	-	-	692655-6	AIR FEED VALVE ASSY	66	
1	1	-	1-460277-9	AIR FEED ASSY (2 INCH)	65	
2	2	-	3-21000-9	SCR, SHC (10-32x1.00)AIR ASSY	64	
-	1	-	980285-2	ELBOW, SWIVEL 1/8 NPT - 1/4 T	63	
-	1	-	23238-1	QUICK DISCONNECT	62	
-	12.00	IN	27319-4	TUBING, POLY-FLO Ø.25	61	
					60	
1	1	-	454220-1	CAP, RAM	59	
1	1	-	453736-1	HOUSING	58	
					57	
					56	
					55	
					54	
4	1	1	-	460680-1	FEED FINGER ASSY	53
					52	
					51	
					50	
					49	
-	1	-	22374-7	VALVE, QUICK EXHAUST	48	
-	1	-	22304-1	NIPPLE, HEX 1/8 NPT	47	
					46	
1	1	-	690191-1	PLUG, NYLON	45	
1	1	-	455674-1	RAM	44	
1	1	-	690125-1	WASHER, LAMINATED	43	
1	1	-	690124-1	WASHER, RAM	42	
1	1	-	690686-1	BOLT, CRIMPER(5/16-24x1.00)	41	
1	1	-	23241-6	BALL, STEEL	40	
1	1	-	690170-1	SPRING, COMPRESSION	39	
1	1	-	690142-1	DISC, INSULATION	38	
1	1	-	354777-1	WIRE DISC, PLASTIC	37	
1	1	-	22480-5	WASHER, SPRING	36	
1	1	-	690212-1	POST, RAM	35	
					34	
					33	
					32	
					31	
					30	
					29	
					28	
1	1	-	240639-3	STRIPPER	27	
1	1	-	455676-5	PLATE, BASE	26	
2	2	-	22354-8	DRAG, STUD	25	
1	1	-	455678-1	PLATE, STRIP GUIDE	24	
					23	
2	2	-	4-22281-1	SPRING, DRAG	22	
					21	
1	1	-	454177-1	DRAG, STOCK	20	
1	1	-	5-458030-2	GUIDE, STRIP (REAR)	19	
1	1	-	5-458031-2	GUIDE, STRIP (FRONT)	18	
					17	
					16	
					15	
1	1	-	2-240641-3	SPACER, SLUG BLADE	14	
					13	
					12	
1	1	1	-	240644-1	PLATE, REAR SHEAR	11
					10	
1	1	-	690482-3	PLATE, FRONT SHEAR	9	
1	1	-	6-461295-1	ANVIL	8	
1	1	-	2-690474-8	BLADE, SLUG	7	
					6	
1	1	-	2-240641-6	SPACER, SLUG BLADE	5	
1	1	-	238009-2	SPACER, BLOCK CRIMPER	4	
1	1	-	1213077-7	CRIMPER, INSULATION	3	
1	1	-	1-455888-5	SPACER, CRIMPER	2	
1	1	-	6-458141-2	CRIMPER, WIRE	1	

QTY	RECD	PER	ASSY	PART NO	DESCRIPTION	ITEM NO
-3	-2	-1	U/M			

QTY	RECD	PER	ASSY	PART NO	DESCRIPTION	ITEM NO
-2	-1	U/M				

- 1 RECOMMENDED SPARE PARTS.
- 2 GREASE LIGHTLY.
- 3 GUARD MUST BE IN PLACE WHEN OPERATING APPLICATOR IN A BENCH MACHINE.
- 4 SEE DRAWING FOR COMPONENTS
- 5 ITEM 78 USED WITH G TERMINATOR ONLY.
- 6 CUT TO LENGTH AT ASSY

LOC A
DIST 66

REV	DATE	BY	CHKD	APVD
B	3-2012	MY	TE	

DWN	P.Mathios	25FEB98	MATERIAL	-	HEAT TREAT	-
CHK	C. Erisman	25FEB98				
APVD	T.ELBIN	25FEB98	STE TE Connectivity			
END FEED HDM APPLICATOR						
SCALE	SIZE	DRAWING NO	SHEET	REV		
-	A1	680592	1	of 1	B	

CUSTOMER ACCESSIBLE PRODUCTION DRAWING