

PI7C8152A & PI7C8152B **2-Port PCI-to-PCI Bridge, 32-bit/66MHz or 33MHz**

PRODUCT FEATURES

- 32-bit / 66MHz or 33MHz Primary and Secondary Ports
 - The Primary and Secondary Ports must both be running at the same frequency in synchronous mode
- Asynchronous mode support (8152B only)
 - Primary and Secondary Ports may run at different frequencies
- Compliant with the following specifications:
 - *PCI Local Bus Specification, Revision 2.2*
 - *PCI-to-PCI Bridge Architecture Specification, Revision 1.1*
 - *Advanced Configuration Power Interface (ACPI) Specification*
 - *PCI Power Management Specification, Revision 1.1*
- Concurrent primary and secondary port operation
- Provides internal arbitration for one set of 4 secondary bus masters
 - Programmable 2-level priority arbiter
 - Disable control to allow use of an external arbiter
- Supports posted write buffers in both directions (downstream and upstream)
- Two 128-byte FIFO's for delay transactions
- Two 128-byte FIFO's for posted memory transactions
- Enhanced address decoding
 - 32-bit I/O address range
 - 32-bit memory-mapped I/O address range
 - 64-bit prefetchable address range
 - VGA addressing and VGA palette snooping
 - ISA-aware mode for legacy support in the first 64KB of I/O address range
- 3.3V core; 3.3V and 5V PCI I/O interface
- Extended commercial temperature range
 - 0°C to 85°C
- 160-pin MQFP package
- Intel 21152 compatible

PRODUCT DESCRIPTION

The PI7C8152 is a 2-port PCI-to-PCI Bridge designed to be fully compliant with the *PCI Local Bus Specification, Revision 2.2*. Both the primary and secondary ports are specified to run at 32-bit / 66MHz or 33MHz (both ports must be running at the same frequency in synchronous mode).

The PI7C8152A supports synchronous bus transactions between devices on the primary bus and the secondary bus. The two buses can operate in concurrent mode, resulting in added increase in system performance. Concurrent bus operation off-loads and isolates traffic on a single bus by allowing a master and target on the same bus to communicate with each other while the other bus is busy.

The PI7C8152B has the added capability of supporting asynchronous bus transactions.

Supported modes of Asynchronous Operation

Primary	Secondary
25MHz to 66MHz	25MHz to 66MHz

The *PCI Local Bus Specification* denotes loading restrictions on the PCI bus. The PI7C8152 allows designers to expand the loading capability by adding a second PCI bus. On motherboards, more PCI slots or devices can then be added on this second PCI bus. On add-in cards, more than one device can now reside on the add-in card (*PCI Local Bus Specifications* specify that each add-in card may only have one device because there may only be one connection per PCI signal in the add-in card connector).

ORDERING INFORMATION

PART NUMBER	SPEED	PACKAGE
PI7C8152AMA	66 MHz or 33 MHz	160-MQFP
PI7C8152BMA	66 MHz or 33 MHz	160-MQFP

PI7C8152 APPLICATION EXAMPLES

PCI Bus Expansion

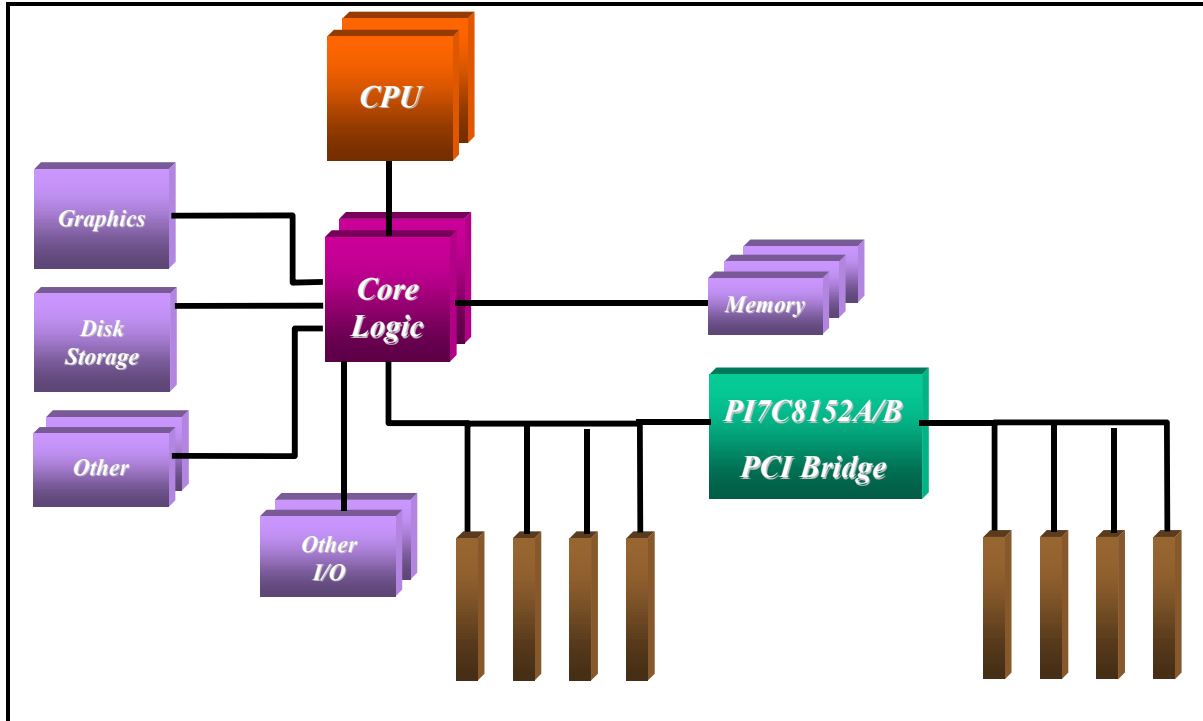

Multiple Devices on PCI Add-In Cards

