

## L99MOD5xXP family evaluation kit for automotive applications



### Features

- MOSFET and diode reverse battery protection network
- Possibility of powering at 12 V through daughterboard connector
- Half-bridge and high-side outputs available depending on the specific device

### Applications

- Multiple **brushed DC motors** and additional loads in high-side configuration, such as bulbs, LEDs or protected supply

### Description

The EVAL-L99MOD5xXP evaluation kit consists in a motherboard and a daughterboard on which the L99MOD5xXP device is assembled. Both of these evaluation boards provide electronic control modules with enhanced power management functionalities including a standby mode.

The motherboard, based on the SPC56 microcontroller, provides the logic section for driving and monitoring the L99MOD5xXP device assembled on the daughterboard.

With the aim of facilitating the use and configuration of the board, ST provides a dedicated user-friendly software with a graphic user interface (GUI) which can be downloaded from STMicroelectronics's website.

The GUI enables the user to set the L99MOD5xXP parameters and get real time information from the device, such as registers status, analog current sense, fault flags and much more.

#### Product status links

##### EVAL-L99MOD5xXP family

[EVAL-L99MOD50XP](#)

[EVAL-L99MOD51XP](#)

[EVAL-L99MOD53XP](#)

[EVAL-L99MOD54XP](#)

# 1 Application schematics and layout

Figure 1. EVAL-L99MOD5xXP top layer and Figure 2. EVAL-L99MOD5xXP bottom layer show the top and bottom layer of the L99MOD5xXP daughterboard.

Figure 3. EVAL-L99MOD5xXP schematic shows the EVAL-L99MOD5xXP schematic.

Figure 1. EVAL-L99MOD5xXP top layer

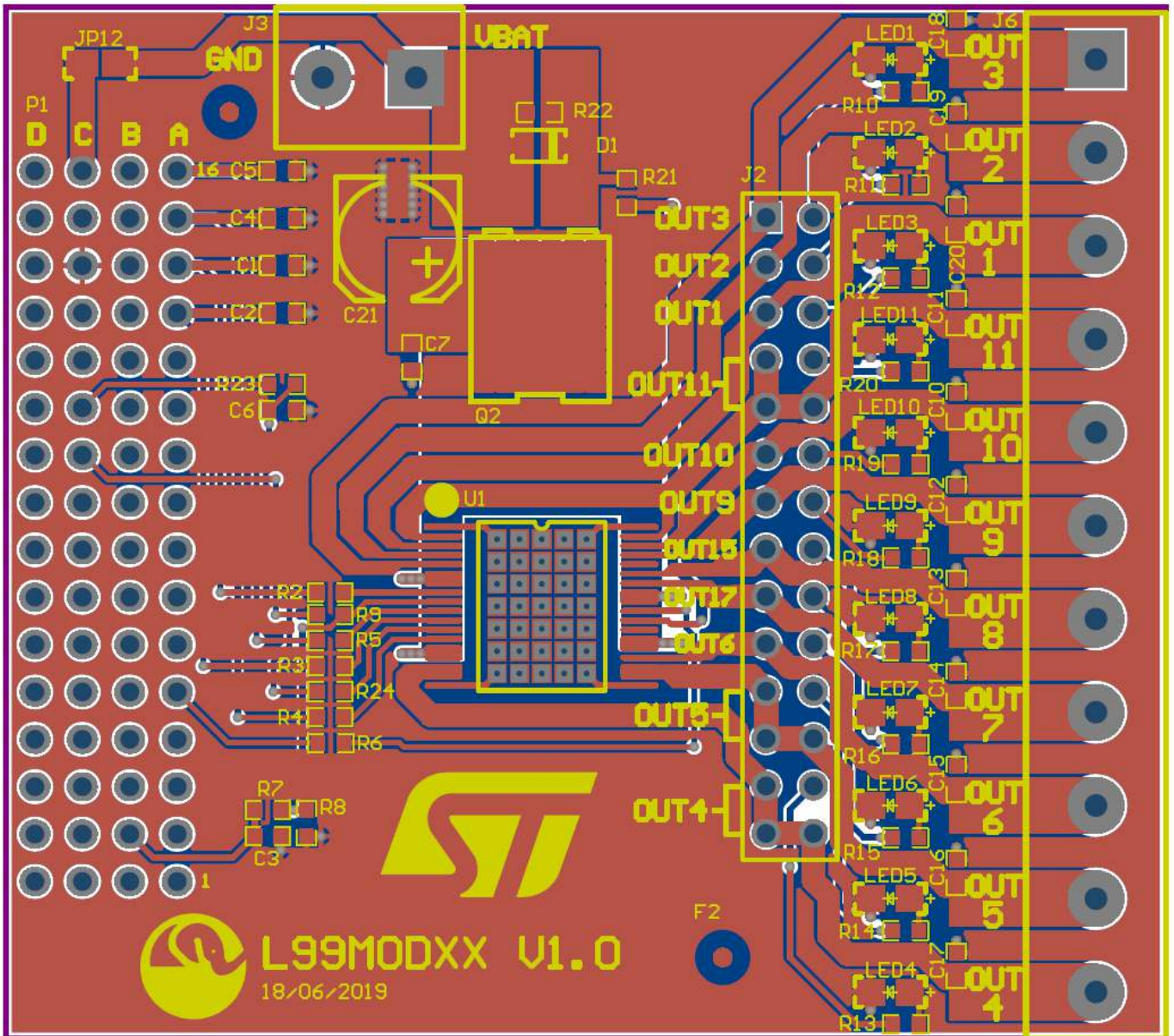

Figure 2. EVAL-L99MOD5xXP bottom layer

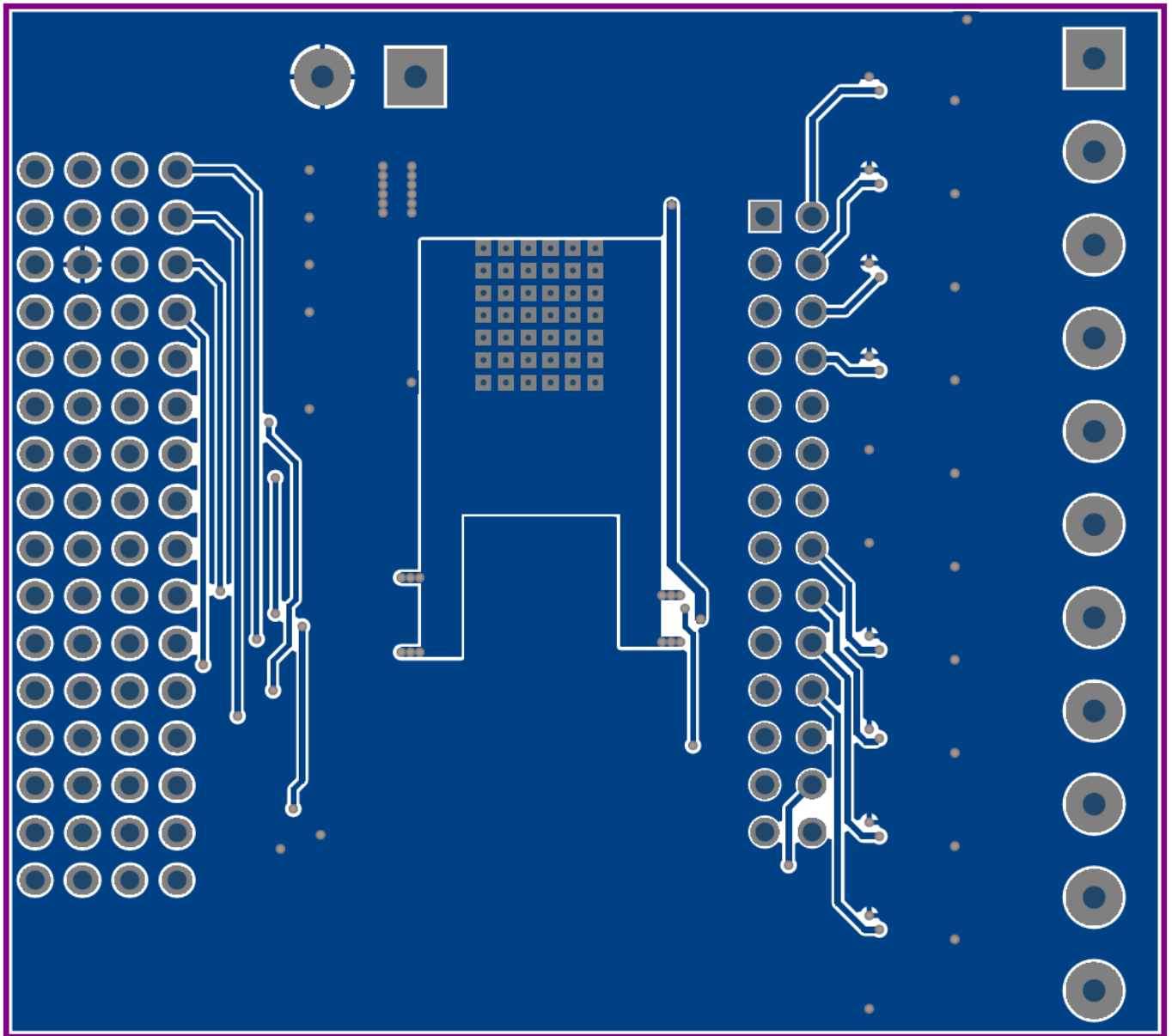
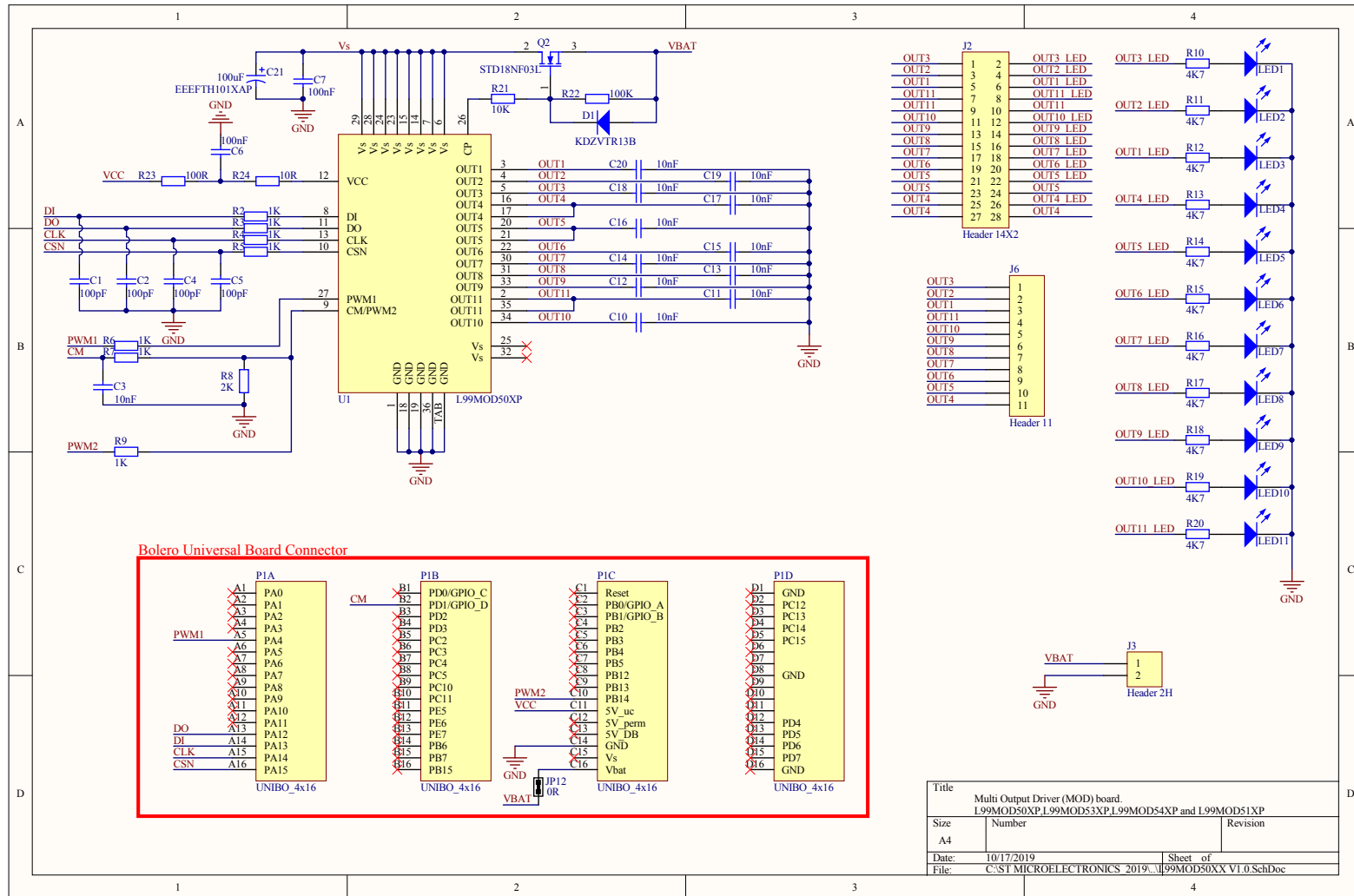

Figure 3. EVAL-L99MOD5xXP schematic



## 2 Demonstration software

---

A software graphical user interface (GUI) for easy demonstration of the L99MOD5xXP features is available for download on [www.st.com](http://www.st.com), under product code **STSW-L99MOD5xXP**.

To use the demonstration software, it is necessary to download and install the VISA and LabVIEW Run-Time Engine software from the supplier's website.

### **3 System requirements**

---

- Windows OS (XP, 7, 8, 10)
- USB port

## 4 Ordering information

**Table 1. Ordering information**

Part number	Order code	Reference
EVAL-L99MOD50XP	EVAL-L99MOD50XP	L99MOD50XPTR evaluation board
EVAL-L99MOD51XP	EVAL-L99MOD51XP	L99MOD51XPTR evaluation board
EVAL-L99MOD53XP	EVAL-L99MOD53XP	L99MOD53XPTR evaluation board
EVAL-L99MOD54XP	EVAL-L99MOD54XP	L99MOD54XPTR evaluation board

## Revision history

**Table 2. Document revision history**

Date	Version	Changes
20-Nov-2019	1	First release.



**IMPORTANT NOTICE – PLEASE READ CAREFULLY**

STMicroelectronics NV and its subsidiaries (“ST”) reserve the right to make changes, corrections, enhancements, modifications, and improvements to ST products and/or to this document at any time without notice. Purchasers should obtain the latest relevant information on ST products before placing orders. ST products are sold pursuant to ST’s terms and conditions of sale in place at the time of order acknowledgement.

Purchasers are solely responsible for the choice, selection, and use of ST products and ST assumes no liability for application assistance or the design of Purchasers’ products.

No license, express or implied, to any intellectual property right is granted by ST herein.

Resale of ST products with provisions different from the information set forth herein shall void any warranty granted by ST for such product.

ST and the ST logo are trademarks of ST. For additional information about ST trademarks, please refer to [www.st.com/trademarks](http://www.st.com/trademarks). All other product or service names are the property of their respective owners.

Information in this document supersedes and replaces information previously supplied in any prior versions of this document.

© 2019 STMicroelectronics – All rights reserved