

DO NOT
SCALE FROM
THIS PRINT

RECOMMENDED PANEL HOLE
(SEE NOTE 3)

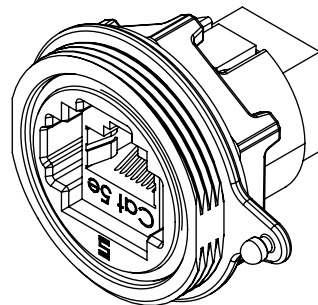
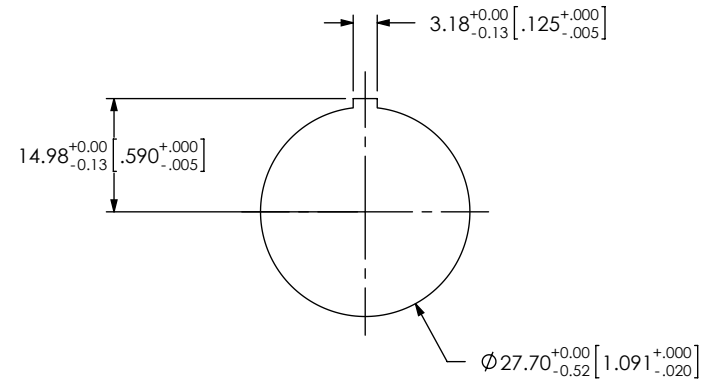

NOTES:

1. Ⓢ REPRESENTS A CRITICAL DIMENSION.
2. ASSEMBLY TO MEET UL 94V-0.
3. PANEL THICKNESS: 0.8 [.03] - 5.2 [.205].
4. TORQUE SPECIFICATION FOR NUT ON SCRE-01 IS 12 IN-LB.
5. SCREA MUST BE FULLY INSERTED INTO SUB-SCRE BEFORE MEASURING.
6. PARTS TO BE PACKAGED IN TRAYS.

UNLESS OTHERWISE SPECIFIED,
DIMENSIONS ARE IN MILLIMETERS.
TOLERANCES ARE:
DECIMALS ANGLES
.X: ± 0.3 [.01] 2°
.XX: ± 0.13 [.005]
.XXX: ± 0.051 [.0020]

PROPRIETARY NOTE

THIS DOCUMENT CONTAINS INFORMATION
CONFIDENTIAL AND PROPRIETARY TO
SAMTEC, INC. AND SHALL NOT BE REPRODUCED
OR TRANSFERRED TO OTHER DOCUMENTS OR
DISCLOSED TO OTHERS OR USED FOR ANY
PURPOSE OTHER THAN THAT WHICH IT WAS
OBTAINED WITHOUT THE EXPRESSED WRITTEN
CONSENT OF SAMTEC, INC.



520 PARK EAST BLVD, NEW ALBANY, IN 47150
PHONE: 812-944-6733 FAX: 812-948-5047
e-Mail: info@SAMTEC.com code: 55322

MATERIAL: DO NOT SCALE DRAWING SHEET SCALE: 1:1
OR-17-01: SILICONE
PBM-17-02: PA66
SPG-17-01: SILICONE
SPN-17-01: PA66
SCREA-H-01-S INSULATOR: PBT
SCREA-H-01-S CONTACTS: PHOS BRONZE
SCREA-H-01-S SHIELDS: COPPER ALLOY
F:\DWG\MISC\MKTG\SCRE-01-MKT.SLDDRW

DESCRIPTION:
ETHERNET PANEL MOUNT ASSEMBLY

DWG. NO.
SCRE-01

BY: CHAD F 12/13/2004 SHEET 1 OF 1