

TLE4966K

High Precision Hall-Effect Switch with
Direction Detection

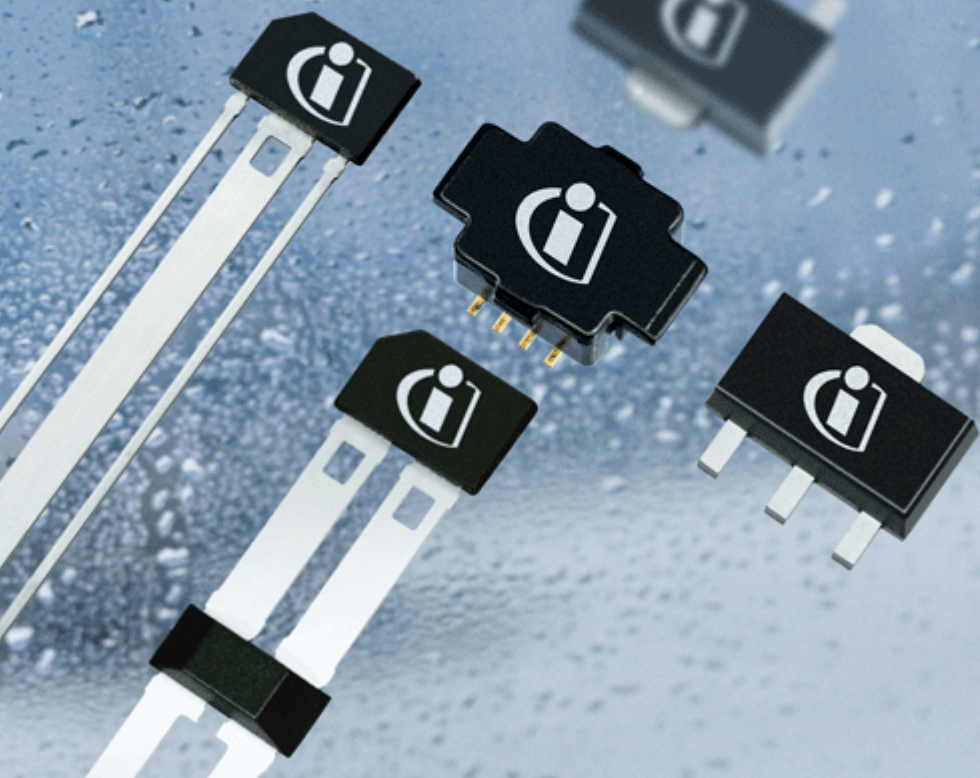

Sensors



Never stop thinking

Edition 2019-10-25

**Published by
Infineon Technologies AG
81726 München, Germany
© 2007 Infineon Technologies AG
All Rights Reserved.**

Legal Disclaimer

The information given in this document shall in no event be regarded as a guarantee of conditions or characteristics. With respect to any examples or hints given herein, any typical values stated herein and/or any information regarding the application of the device, Infineon Technologies hereby disclaims any and all warranties and liabilities of any kind, including without limitation, warranties of non-infringement of intellectual property rights of any third party.

Information

For further information on technology, delivery terms and conditions and prices, please contact the nearest Infineon Technologies Office (www.infineon.com).

Warnings

Due to technical requirements, components may contain dangerous substances. For information on the types in question, please contact the nearest Infineon Technologies Office.

Infineon Technologies components may be used in life-support devices or systems only with the express written approval of Infineon Technologies, if a failure of such components can reasonably be expected to cause the failure of that life-support device or system or to affect the safety or effectiveness of that device or system. Life support devices or systems are intended to be implanted in the human body or to support and/or maintain and sustain and/or protect human life. If they fail, it is reasonable to assume that the health of the user or other persons may be endangered.

Revision History: **2019-10-25**

Rev. 1.01

Previous Version: 2007-09

Page	Subjects (major changes since last revision)

We Listen to Your Comments

Any information within this document that you feel is wrong, unclear or missing at all? Your feedback will help us to continuously improve the quality of this document. Please send your proposal (including a reference to this document) to:

sensors@infineon.com



1	Overview	6
1.1	Features	6
1.2	Functional Description	6
1.3	Pin Configuration (top view)	7
2	General	8
2.1	Block Diagram	8
2.2	Circuit Description	8
3	Maximum Ratings	9
4	Operating Range	10
5	Electrical and Magnetic Parameters	11
	Field Direction Definition	12
6	Timing Diagrams for the Speed and Direction Outputs	13
7	Package Information	15
7.1	Package Marking	15
7.2	Distance between Chip and Package Surface	15
7.3	Package Outlines	16
	PCB Footprint for PG-TSOP6-6-5	16



1 Overview

1.1 Features

- 2.7 V to 24 V supply voltage operation
- Operation from unregulated power supply
- High sensitivity and high stability of the magnetic switching points
- High resistance to mechanical stress by Active Error Compensation
- Reverse battery protection (-18 V)
- Superior temperature stability
- Peak temperatures up to 195°C without damage
- Low jitter (typ. 1 μ s)
- Digital output signals
- Bipolar version
- Excellent matching between the 2 Hall probes
- Hall plate distance 1.45 mm
- Direction & speed information
- Direction signal switches before the speed signal
- SMD package PG-TSOP6-6-5



1.2 Functional Description

The TLE4966K is an integrated circuit double Hall-effect sensor designed specifically for highly accurate applications. Precise magnetic switching points and high temperature stability are achieved by active compensation circuits and chopper techniques on chip. They provide a speed signal at Q2 for every magnetic pole pair and a direction information at Q1, which is provided before the speed signal.

Type	Ordering Code	Package
TLE4966K	SP000392740	PG-TSOP6-6-5

1.3 Pin Configuration (top view)

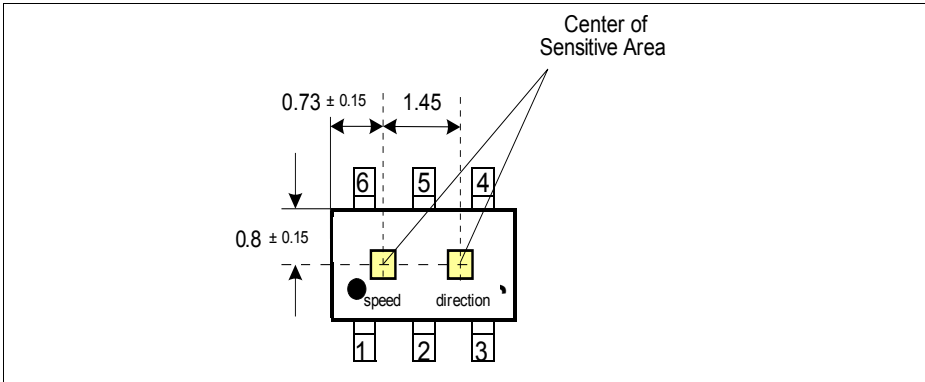

Figure 1 Pin Definition and Center of Sensitive Area

Table 1 Pin Definitions and Functions PG-TSOP6-6-5

Pin No.	Symbol	Function
1	Q2	Speed
2	GND	Recommended connection to GND
3	Q1	Direction
4	V_S	Supply voltage
5	GND	Recommended connection to GND
6	GND	Ground

2 General

2.1 Block Diagram

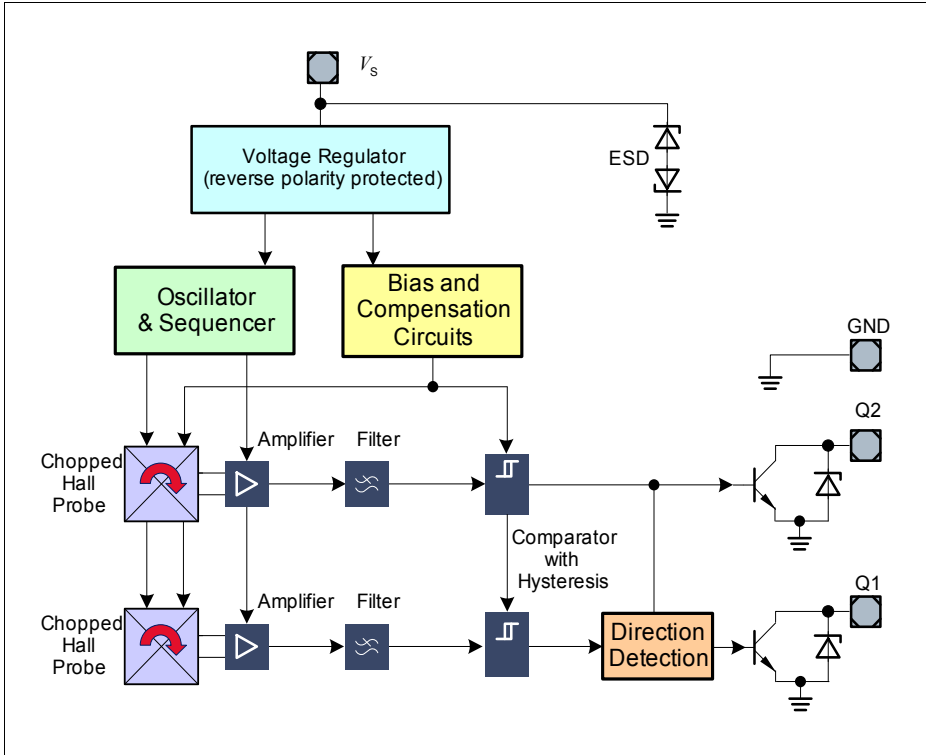

Figure 2 Block Diagram

2.2 Circuit Description

The chopped Double Hall Switch comprises two Hall probes, bias generator, compensation circuits, oscillator, and output transistors.

The bias generator provides currents for the Hall probes and the active circuits. Compensation circuits stabilize the temperature behavior and reduce technology variations.

The Active Error Compensation rejects offsets in signal stages and the influence of mechanical stress to the Hall probes caused by molding and soldering processes and other thermal stresses in the package. This chopper technique together with the threshold generator and the comparator ensures high accurate magnetic switching points.

3 Maximum Ratings

Table 2 Absolute Maximum Ratings
 $T_j = -40^\circ\text{C}$ to 150°C

Parameter	Symbol	Limit Values		Unit	Conditions
		min.	max.		
Supply voltage	V_S	-18 -18 -18	18 24 26	V	for 1 h, $R_S \geq 200 \Omega$ for 5 min, $R_S \geq 200 \Omega$
Supply current through protection device	I_S	-50	50	mA	
Output voltage	V_Q	-0.7 -0.7	18 26	V	for 5 min @ 1.2 k Ω pull up
Continuous output current	I_Q	-50	50	mA	
Junction temperature	T_j	– – – –	155 165 175 195	$^\circ\text{C}$	for 2000 h (not additive) for 1000 h (not additive) for 168 h (not additive) for 3 x 1 h (additive)
Storage temperature	T_S	-40	150	$^\circ\text{C}$	
Magnetic flux density	B	–	unlimited	mT	

Note: Stresses above those listed here may cause permanent damage to the device. Exposure to absolute maximum rating conditions for extended periods may affect device reliability.

Table 3 ESD Protection ¹⁾

Parameter	Symbol	Limit Values		Unit	Notes
		min.	max.		
ESD voltage	V_{ESD}	–	± 4	kV	HBM, $R = 1.5 \text{ k}\Omega$, $C = 100 \text{ pF}$ $T_A = 25^\circ\text{C}$

1) Human Body Model (HBM) tests according to: EOS/ESD Association Standard S5.1-1993 and Mil. Std. 883D method 3015.7

4 Operating Range

Table 4 Operating Range

Parameter	Symbol	Limit Values			Unit	Conditions
		min.	typ.	max.		
Supply voltage	V_S	2.7 – –	– – –	18 24 26	V	1 h with $R_S \geq 200 \Omega$ for 5 min $R_S \geq 200 \Omega$
Output voltage	V_Q	-0.7	–	18	V	
Junction temperature	T_j	-40 –	– –	150 175	°C	for 168 h
Output current	I_Q	0	–	10	mA	

5 Electrical and Magnetic Parameters

Table 5 Electrical Characteristics ¹⁾

Parameter	Symbol	Limit Values			Unit	Conditions
		min.	typ.	max.		
Supply current	I_S	4	5.2	7	mA	$V_S = 2.7 \text{ V} \dots 18 \text{ V}$
Reverse current	I_{SR}	0	0.2	1	mA	$V_S = -18 \text{ V}$
Output saturation voltage	V_{QSAT}	–	0.3	0.6	V	$I_Q = 10 \text{ mA}$
Output leakage current	I_{QLEAK}	–	0.05	10	μA	for $V_Q = 18 \text{ V}$
Output fall time	t_f	–	0.2	1	μs	$R_L = 1.2 \text{ k}\Omega$; $C_L < 50 \text{ pF}$ see: Figure 3
Output rise time	t_r	–	0.2	1	μs	
Chopper frequency	f_{OSC}	–	320	–	kHz	
Switching frequency	f_{SW}	0	–	15 ²⁾	kHz	
Delay time ³⁾	t_d	–	13	–	μs	
Count Signal Delay	t_{dc}	50	200	1000	ns	
Output jitter ⁴⁾	t_{QJ}	–	1	–	μs_{RMS}	Typ. value for square-wave signal 1 kHz
Repeatability of magnetic thresholds ⁵⁾	B_{REP}	–	40	–	μT_{RMS}	Typ. value for $\Delta B/\Delta t > 12 \text{ mT/ms}$
Power-on time ⁶⁾	t_{PON}	–	13	–	μs	$V_S \geq 2.7 \text{ V}$
Distance of hall plates	d_{HALL}	–	1.45	–	mm	
Thermal resistance ⁷⁾	R_{thJA}	–	100	–	K/W	PG-TSOP6-6-5

1) over operating range, unless otherwise specified. Typical values correspond to $V_S = 12 \text{ V}$ and $T_A = 25^\circ\text{C}$

2) To operate the sensor at the max. switching frequency, the magnetic signal amplitude must be 1.4 times higher than for static fields. This is due to the -3 dB corner frequency of the low pass filter in the signal path.

3) Systematic delay between magnetic threshold reached and output switching

4) Jitter is the unpredictable deviation of the output switching delay

5) B_{REP} is equivalent to the noise constant

6) Time from applying $V_S \geq 2.7 \text{ V}$ to the sensor until the output state is valid

7) Thermal resistance from junction to ambient

Electrical and Magnetic Parameters
Calculation of the ambient temperature (PG-TSOP6-6-5 example)

e.g. for $V_S = 12.0\text{ V}$, $I_{Styp} = 5.5\text{ mA}$, $V_{QSATtyp} = 0.3\text{ V}$ and $2 \times I_Q = 10\text{ mA}$:

Power Dissipation: $P_{DIS} = 72.0\text{ mW}$.

In $T_A = T_j - (R_{thJA} \times P_{DIS}) = 175^\circ\text{C} - (100\text{ K/W} \times 0.072\text{ W})$

Resulting max. ambient temperature: $T_A = 167.8^\circ\text{C}$

Table 6 Magnetic Characteristics ¹⁾

Parameter	Symbol	T_j [°C]	Limit Values			Unit	Conditions
			min.	typ.	max.		
Operate point	B_{OP}	-40	5.2	7.7	10.3	mT	
		25	5.0	7.5	10.0		
		150	4.7	7.1	9.5		
Release point	B_{RP}	-40	-10.3	-7.7	-5.2	mT	
		25	-10.0	-7.5	-5.0		
		150	-9.5	-7.1	-4.7		
Hysteresis	B_{HYS}	-40	–	–	–	mT	
		25	10.0	15.0	20.0		
		150	–	–	–		
Magnetic matching	B_{MATCH}	-40	–	–	–	mT	Valid for $B_{OP1} - B_{OP2}$ and $B_{RP1} - B_{RP2}$
		25	-2.0	0	2.0		
		150	–	–	–		
Magnetic offset	B_{OFF}	-40	–	–	–	mT	$(B_{OP} + B_{RP})/2$
		25	-2.0	0	2.0		
		150	–	–	–		
Temperature compensation of magnetic thresholds	TC	–	–	-350	–	ppm/°C	

1) over operating range, unless otherwise specified. Typical values correspond to $V_S = 12\text{ V}$

Note: Typical characteristics specify mean values expected over the production spread.

Field Direction Definition

Positive magnetic fields related with south pole of magnet to the branded side of package.

Timing Diagrams for the Speed and Direction Outputs

6 Timing Diagrams for the Speed and Direction Outputs

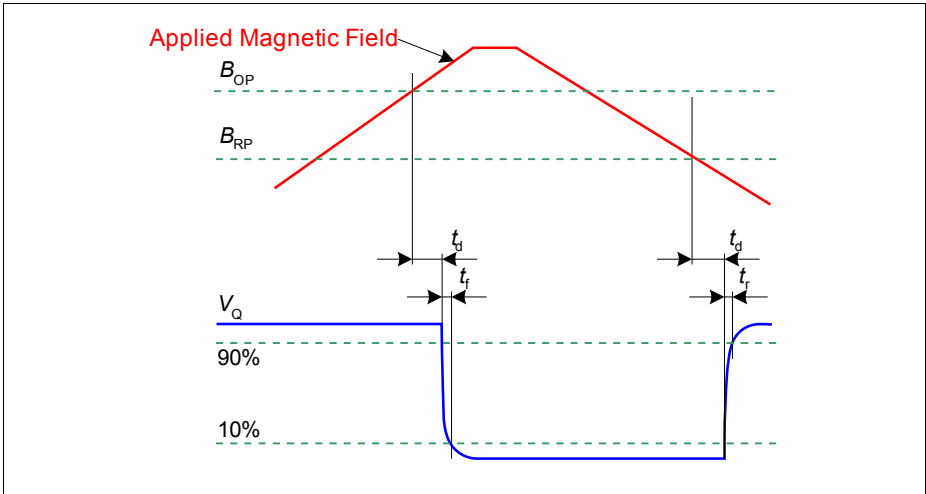

Figure 3 Timing Definition of the Speed Signal

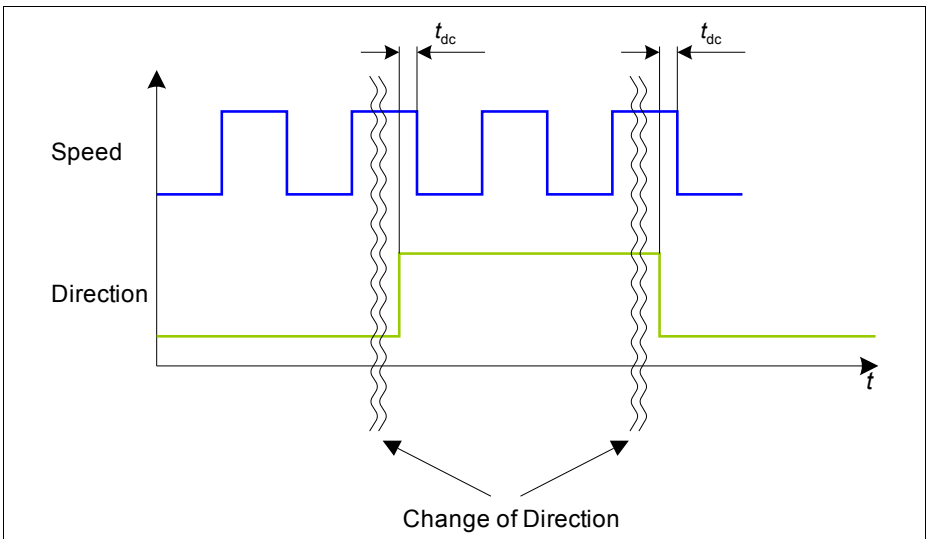

Figure 4 Timing Definition of the Direction Signal

Timing Diagrams for the Speed and Direction Outputs

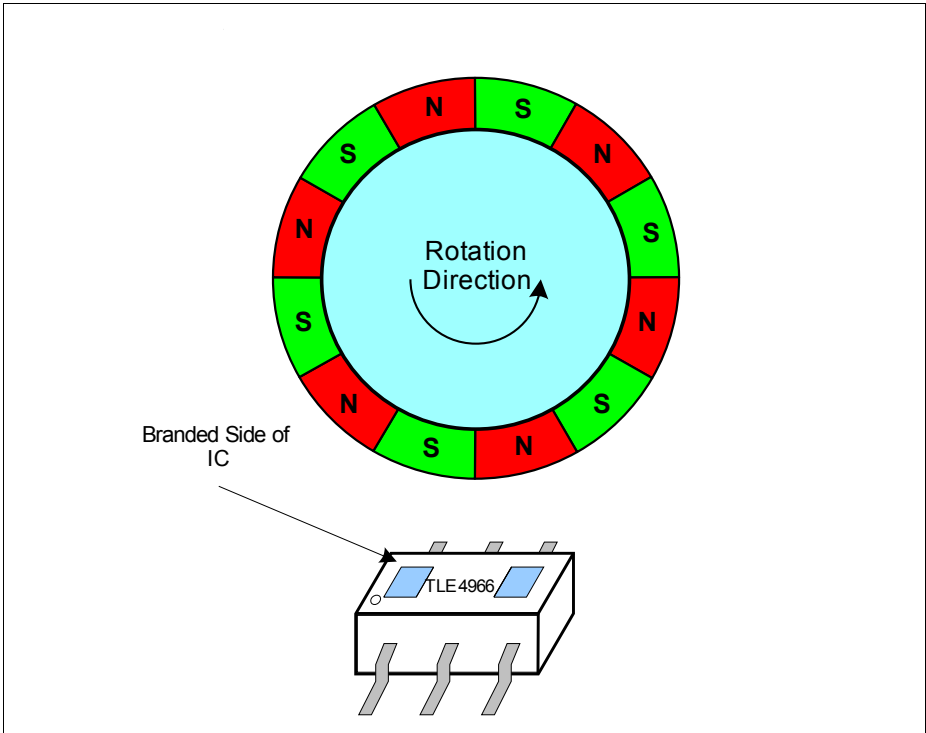

Figure 5 Definition of the Direction Signal

Rotation Direction	State of Direction Output V_{Q1}
Left to right	Low
Right to left	High

7 Package Information

7.1 Package Marking

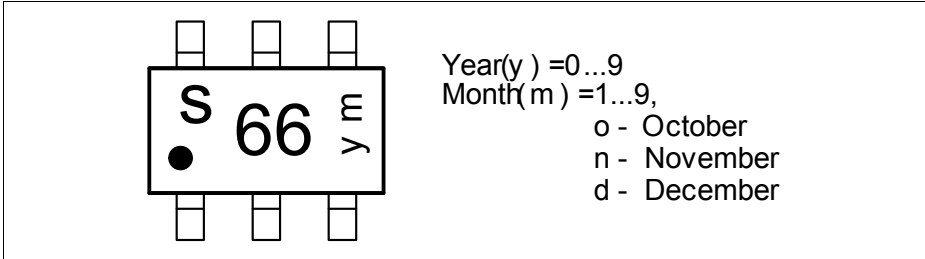

Figure 6 Marking PG-TSOP6-6-5

7.2 Distance between Chip and Package Surface

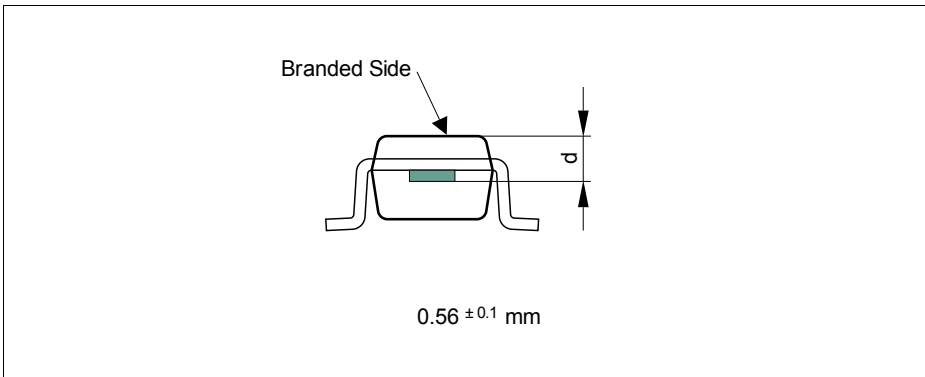

Figure 7 Distance Chip to Upper Side of IC

7.3 Package Outlines

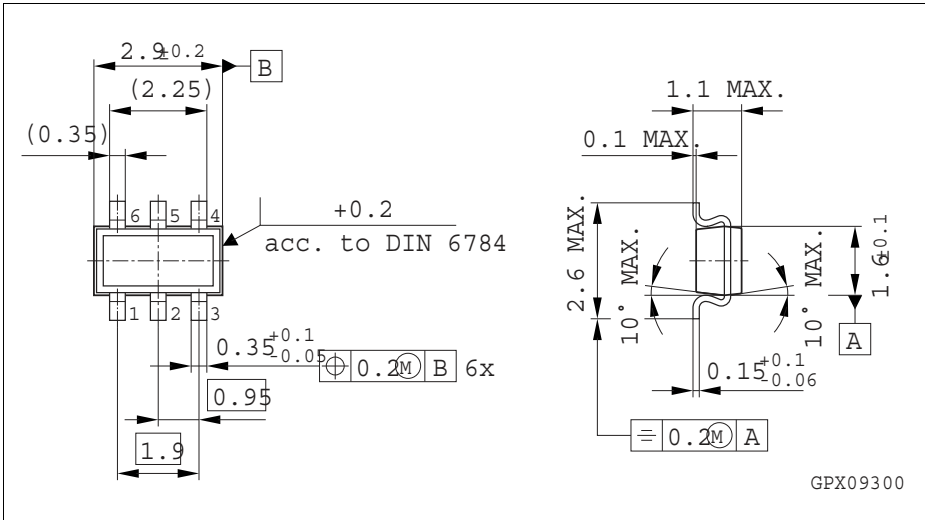

Figure 8 PG-TSOP6-5 (Plastic Thin Small Outline Package)

PCB Footprint for PG-TSOP6-5

The following picture shows a recommendation for the PCB layout.

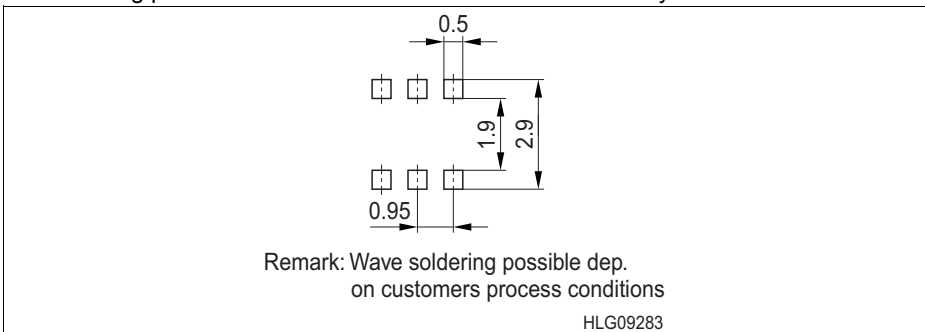

Figure 9 Footprint PG-TSOP6-5

You can find all of our packages, sorts of packing and others in our Infineon Internet Page "Products": <http://www.infineon.com/products>.

Dimensions in mm

www.infineon.com

Published by Infineon Technologies AG