

Specifications

Drawing No.	USY1M-H1-17106-00	1 / 10
Issued Date.	Feb,7,2017	

Messrs: Digi-Key

Note: Part Number will be revised in case of specification change.

Product Type	Quartz Crystal
Series	CX1612DB
Frequency	48000kHz
Customer Part Number	-
Customer Specification Number	-
KYOCERA Part Number	CX1612DB48000D0FPJC1
Remarks	Pb-Free, RoHS Compliant, MSL 1

Customer Approval

Approval Signature	Approved Date	
	Department	
	Person in charge	

Seller

KYOCERA Crystal Device Corporation

(Sales Division)

6 Takeda Tobadono-cho, Fushimi-ku, Kyoto

612-8501 Japan

TEL. No. 075-604-3500

FAX. No. 075-604-3501

Manufacturer

KYOCERA Crystal Device Corporation

(Crystal Units Division)

5850, Higashine-Koh, Higashine-Shi, Yamagata

999-3701 Japan

TEL. No. 0237-43-5611

FAX. No. 0237-43-5615

Design Department	Quality Assurance	Approved by	Checked by	Issued by
KYOCERA Crystal Device Corporation Crystal Unit Design Engineering Section Crystal Units Division	S.Ito	T.Soda	A.Muraoka	T.Sudou Y.Nozaki

Revision History

Rev.No.	Description of revision	Date	Approved by	Checked by	Issued by
00	First Edition	Feb,7,2017	T.Soda	A.Muraoka	T.Sudou Y.Nozaki

1. APPLICATION

This specification sheet is applied to quartz crystal "CX1612DB"

2. KYOCERA PART NUMBER

CX1612DB48000D0FPJC1

3. RATINGS

Items	SYMB.	Rating	Unit	Remarks
Operating Temperature range	Topr	-40 to +85	°C	
Storage Temperature range	Tstg	-40 to +85	°C	

4. CHARACTERISTICS

ELECTRICAL CHARACTERISTICS

Items	Electrical Specification					Test Condition	Remarks
	SYMB.	Min	Typ.	Max	Unit		
Mode of Vibration		Fundamental					
Nominal Frequency	F0		48		MHz		
Nominal Temperature	T _{NOM}		+25		°C		
Load Capacitance	CL	8.0			pF		
Frequency Tolerance	df/F	-10.0		+10.0	ppm	+25±3°C	
Frequency Temperature Characteristics	df/F	-15.0		+15.0		-40 to +85°C	@35°C
Frequency Aging Rate		-1.0		+1.0		1year	
Drive Level	Pd	0.01		100	μW		
Equivalent Series Resistance	ESR			50	Ω		
Insulation Resistance	IR	500			MΩ	100V(DC)	

5. Measurement Condition

5.1 Frequency measurement

Measuring instrument : IEC PI-Network Test Fixture
IEC 60444-8 STD (Pi circuit 41901A)

5.2 Equivalent series resistance (ESR) measurement

Measuring instrument : IEC PI-Network Test Fixture
Load Capacitance : Series

6. APPEARANCES, DIMENSIONS
OUTLINE DIMENSION (not to scale)

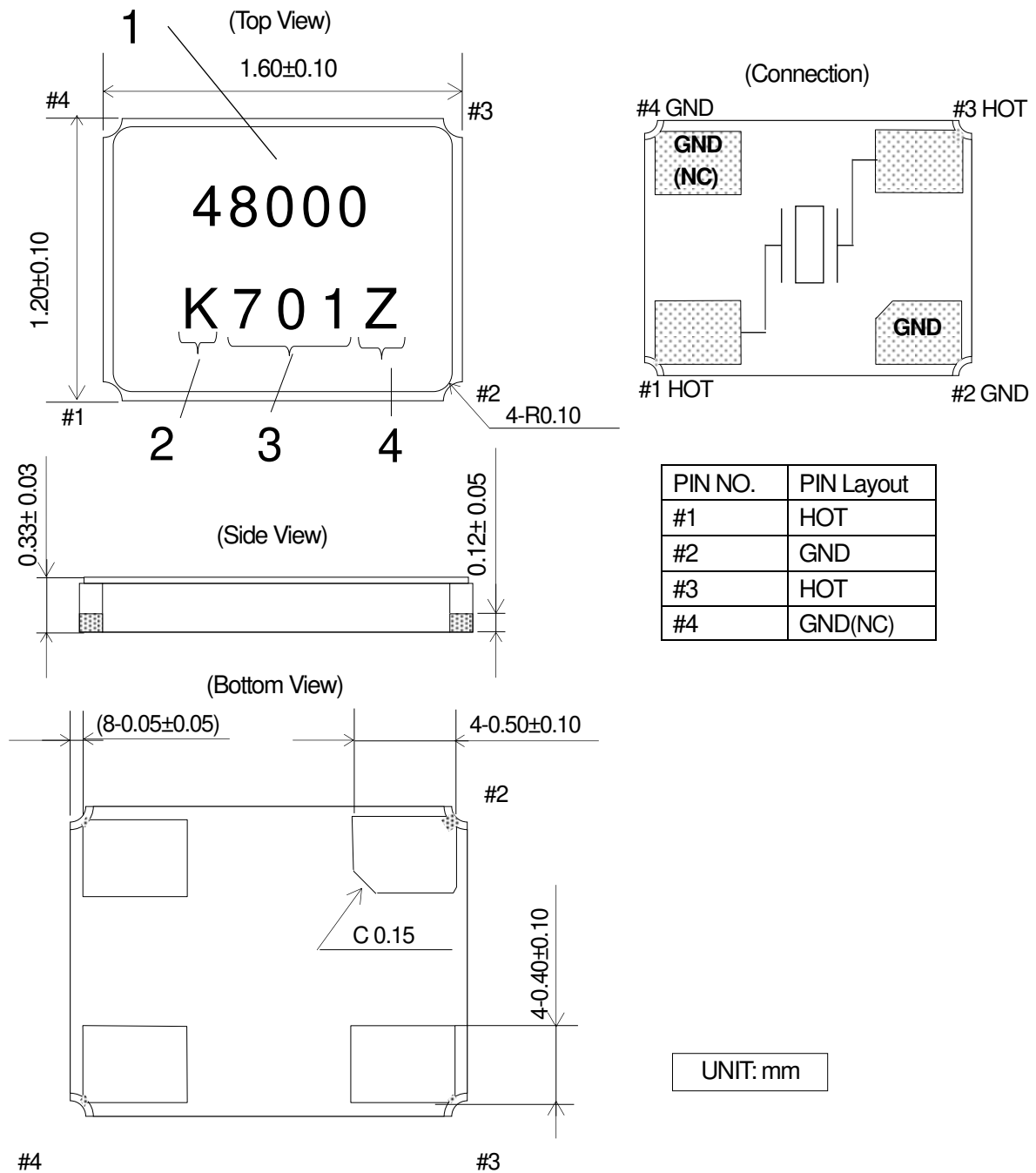

MARKING

- (1) Nominal Frequency First 5digits of the frequency are indicated.
- (2) Identification [K] is to indicate 1Pin direction.
- (3) Date Code Last 1 Digit of YEAR and WEEK (Ex) 2017,Jan,05→ 701
- (4) Manufacturing Location Y: Japan(Yamagata) Z: Japan(Shiga Yohkaichi)
T: Thailand

***The font of marking is for reference only.**

KYOCERA Crystal Device Corporation

7. RECOMMENDED LAND PATTERN (not to scale)

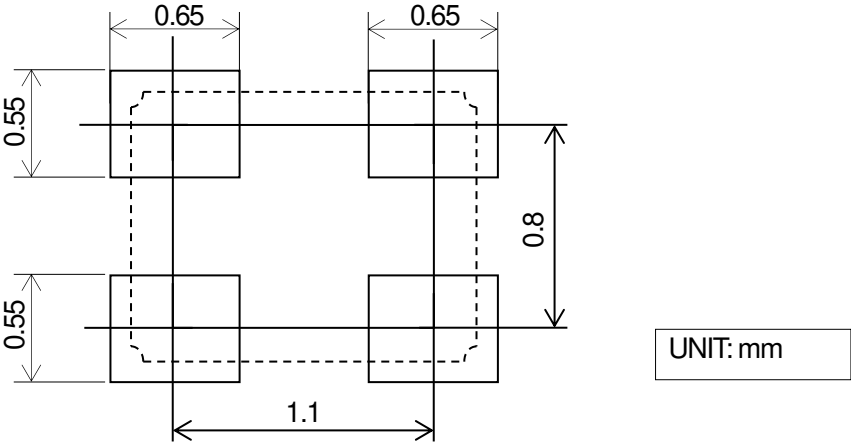

8. TAPING & REEL

8-1. Dimensions

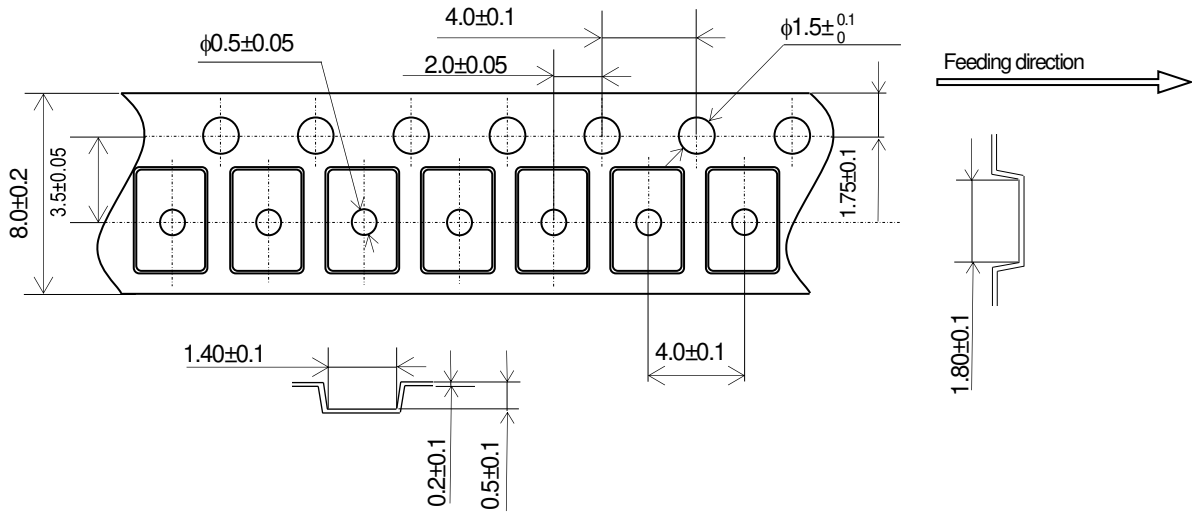

8-2. Leader and Carrier tape

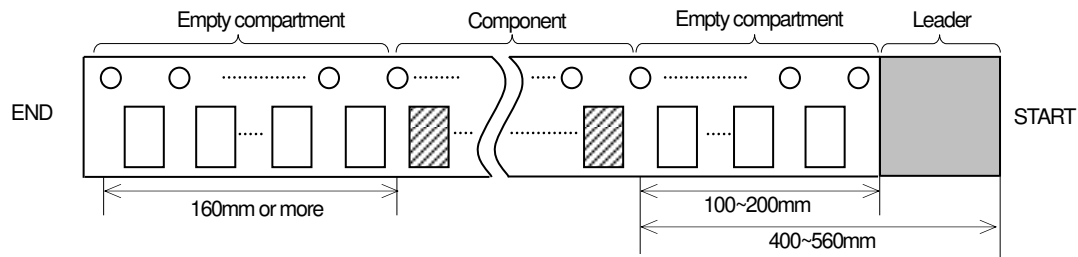

8-3. Direction (Orientation shall be checked from the top cover tape side)

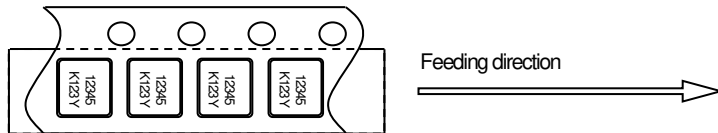

8-4. Specification

1. Material of the carrier tape is either polystyrene or A-PET (ESD).
2. Material of the cover tape is polyester (ESD).
3. The seal tape shall not cover the sprocket holes and not protrude from the carrier tape.
4. Tensile strength of carrier tape: 10N or more.
5. The R of the corner of each cavity is 0.2RMAX.
6. The alignment between centers of the cavity and sprocket hole shall be 0.05mm or less.
7. The orientation shall be checked from the top cover tape side as shown in 7-3.
8. Peeling force of cover tape: 0.1 to 1.0N.
9. The component will fall out naturally when cover tape is removed and set upside down.

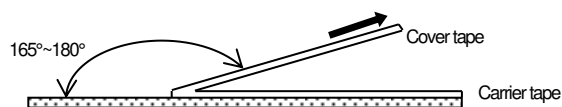

8-5.Reel Specification

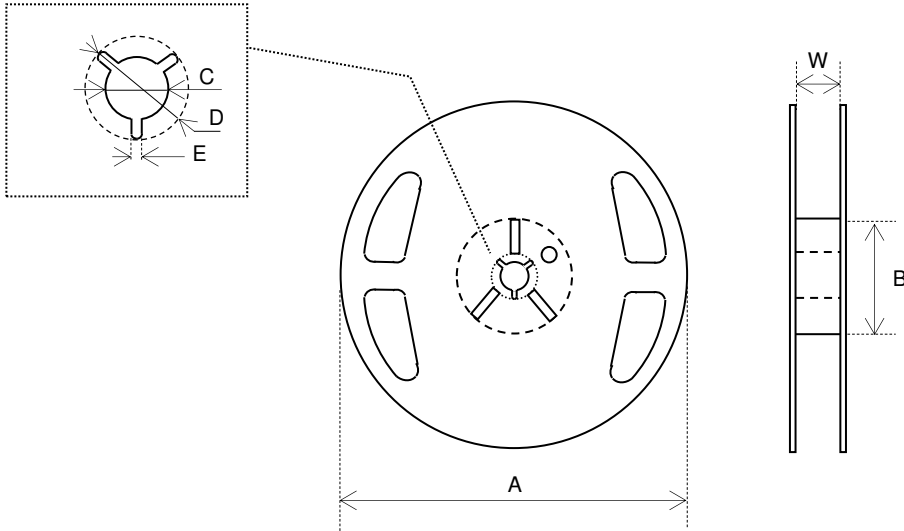

φ180 Reel 3,000pcs (5,000 pcs Max.)

Symbol	A	B	C
Dimension	φ180 +0/-3	φ60 +1/-0	φ13±0.2
Symbol	D	E	W
Dimension	φ21±0.8	2.0±0.5	9±1

(Unit: mm)

φ330 Reel 20,000pcs (21,000 pcs Max.)

Symbol	A	B	C
Dimension	φ330±2.0	φ100±1.0	φ13±0.2
Symbol	D	E	W
Dimension	φ21±0.8	2.0±0.5	9.4±1

(Unit: mm)

9.6 Resistance to Moisture Test condition

The quartz crystal unit shall be stored at a temperature of $+60\pm 2^{\circ}\text{C}$ with relative humidity of 90% to 95% for 240 h. Then it shall be subjected to room temperature for 1h before measurement.

9.7 Soldering condition 1.) Type of solder

Material : lead free solder paste
Melting point : $+220\pm 5^{\circ}\text{C}$

2.) Reflow temp.profile

	Temp [°C]	Time[sec]
Preheating	+150 to +180	150 (typ.)
Peak	$+260\pm 5$	10 (max.)
Total	-	300 (max.)

Frequency shift : $\pm 2\text{ppm}$

3.) Hand Soldering $+350^{\circ}\text{C}$ 3 sec max

4.) Reflow Times 2 times in below Reflow temp. profile

Reflow temp.profile

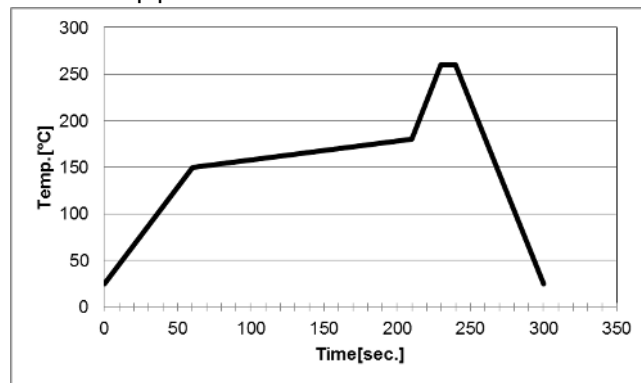

9.8 Bending Strength

Solder this product in center of the circuit board (40mm X 100mm), and add deflection of 3mm.

Test board : $t=1.6\text{mm}$

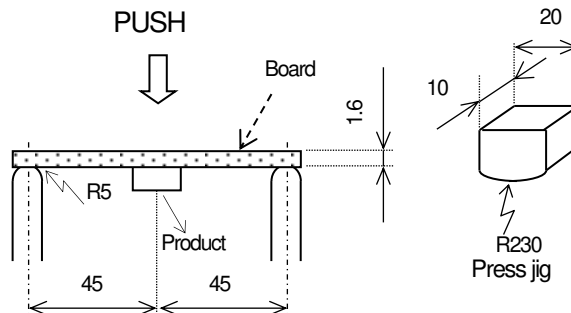

UNIT: mm

10. Cautions for use

(1) Soldering upon mounting

There is a possibility to influence product characteristics when Solder paste or conductive glue comes in contact with product lid or surface.

(2) When using mounting machine

Please minimize the shock when using mounting machine to avoid any excess stress to the product.

(3) Conformity of a circuit

We strongly recommend to make sure that Negative resistance (Gain) of IC is designed to be 5 times the ESR (Equivalent Series Resistance) of crystal unit.

11. Storage conditions

Please store product in below conditions, and use within 6 months.

Temperature +18 to +30°C, and Humidity of 20 to 70 % in the packaging condition.

12. Manufacturing location

Kyocera Crystal Device Corporation Yamagata Plant

Kyocera Crystal Device Corporation Shiga Yohkaichi Plant

Kyocera Crystal Device (Thailand) Co., Ltd

13. Quality Assurance

To be guaranteed by Kyocera Crystal Device Quality Assurance Division

14. Quality guarantee

In case when Kyocera Crystal Device Corporation rooted failure occurred within 1 year after its delivery, substitute product will be arranged based on discussion. Quality guarantee of product after 1 year of its delivery is waived.

15. Others

In case of any questions or opinions regarding the Specification, please have it in written manner within 45 days after issued date.