

PRODUCT NO.
SEE TABLE

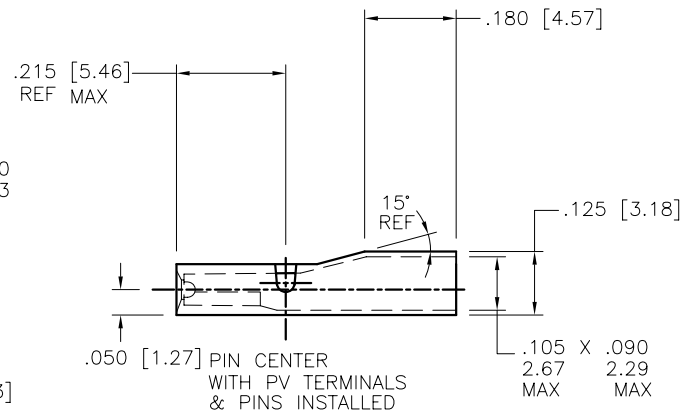
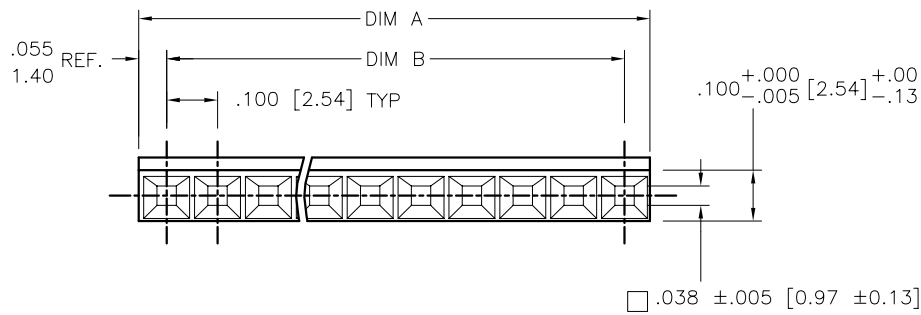
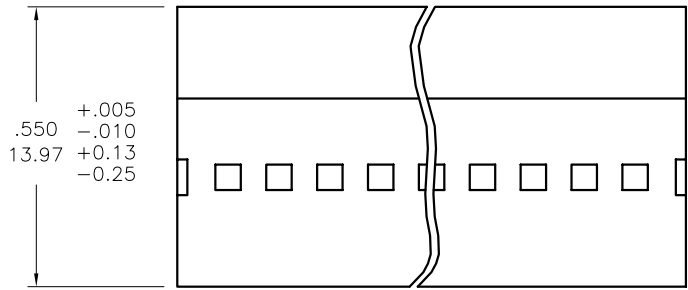

mat'l. code SEE NOTE 1 & 2				surface ✓		tolerance tolerances unless otherwise specified		projection INCH/MM		product family PV HOUSINGS			
ltr	ec'n no	dr	date	tolerances unless otherwise specified		angles		linear		title			
D	v51436	SAR	1996-01-24					.XX+01/XX+3		MINI ROD HSG SR 18 AWG			
E	v90988	RGD	1999-06-23					.XXX+005/XXX+13		.100 [2.54] CC WITH RODS			
F	v05-0712	DAI	2005-07-27	0°±2'				.XXXX+0020/XXX+051		scale 3:1			
G	v06-0448	HTB	2006-05-22	dr	S. ROYER	1996-01-22		FCJ		dwg no			
H	v06-0582	HTB	2006-06-14	engr	T. HANNA	1996-01-22				sheet 1 of 2		size	
J	v07-0563	HTB	2007-08-27	chr	T. BREWBAKER	1996-01-22				65298		A3	
sheet				revision		J		J		type			
index				sheet		1		2		Product Customer Drawing			

PRODUCT NUMBER	NO. OF CAV.	DIM 'A' MAX.	DIM 'B'	ROD INFORMATION		
				ROD P/N	QTY.	DIM 'C'
65298-001LF	4	.425 [10.80]	.300 [7.62]	65048-040	1	1.30/33.02
65298-002LF	5	.525 [13.34]	.400 [10.16]	65048-040	1	1.30/33.02
65298-003LF	6	.625 [15.88]	.500 [12.70]	65048-040	1	1.30/33.02
65298-004LF	7	.725 [18.42]	.600 [15.24]	65048-040	1	1.30/33.02
65298-005LF	8	.825 [20.96]	.700 [17.78]	65048-040	1	1.30/33.02
65298-006LF	9	.925 [23.50]	.800 [20.32]	65048-040	1	1.30/33.02
65298-007LF	10	1.025 [26.04]	.900 [22.86]	65048-026	1	2.30/58.42
65298-008LF	11	1.125 [28.58]	1.000 [25.40]	65048-026	1	2.30/58.42
65298-009LF	12	1.225 [31.12]	1.100 [27.94]	65048-026	1	2.30/58.42
65298-010LF	13	1.325 [33.66]	1.200 [30.48]	65048-026	1	2.30/58.42
65298-011LF	14	1.425 [36.20]	1.300 [33.02]	65048-026	1	2.30/58.42
65298-012LF	15	1.525 [38.74]	1.400 [35.56]	65048-026	1	2.30/58.42
65298-013LF	16	1.625 [41.28]	1.500 [38.10]	65048-026	1	2.30/58.42
65298-014LF	17	1.725 [43.82]	1.600 [40.64]	65048-026	1	2.30/58.42
65298-015LF	18	1.825 [46.36]	1.700 [43.18]	65048-026	1	2.30/58.42
65298-016LF	19	1.925 [48.90]	1.800 [45.72]	65048-026	1	2.30/58.42
65298-017LF	20	2.025 [51.44]	1.900 [48.26]	65048-013	1	3.45/87.63

NOTES:

- ① HOUSING MATERIAL : MODIFIED POLYPHENYLENE ETHER, FLAME RETARDANT PER UL 94-V0, COLOR: BLACK.
- ② ROD MATERIAL : NYLON (NATURAL COLOR) SEE FIGURE #1 FOR DIMENSIONS.
3. TO MAKE PROPER CONTACT, ALL MALE PINS FOR EACH HOUSING MUST BE WITHIN ±.015/0.38 IN LENGTH. MIN. PIN LENGTH IS .180/4.57.
4. MAX. WIRE CRIMP AND WIRE STRANDS ARE SHOWN IN FIGURE #3. SEE MINI PVT™ TERMINAL SPECIFICATION TA-328 FOR CORRECT CRIMP HT. PRODUCT SPECIFICATION : BUS-12-067.
5. THIS HOUSING IS INTENDED FOR USE WITH MINI PVT™ TERMINAL WITH 18 GAUGE WIRE, MEETING SPECIFICATIONS SHOWN IN FIG. #3.
6. HOUSINGS ARE NOT STACKABLE END TO END ON .100/2.54 CENTERS.
7. RETENTION RODS ARE INCLUDED WITH MINI ROD HOUSINGS. RODS TO BE TRIMMED AFTER INSERTION.
8. PRODUCT MEETS EUROPEAN UNION DIRECTIVES AND OTHER COUNTRY REGULATIONS AS DESCRIBED IN GS-22-008.
9. THE PRODUCT IS NOT INTENDED TO BE EXPOSED TO MANUFACTURING SOLDER PROCESS.

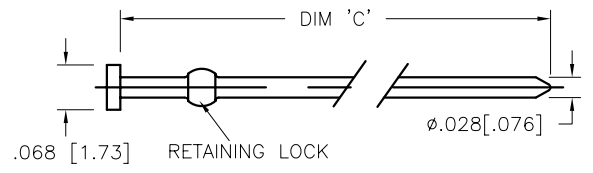

FIG. 1 RETENTION ROD DETAIL
SCALE 4:1

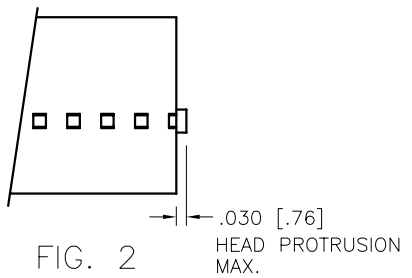

FIG. 2 HEAD PROTRUSION MAX.

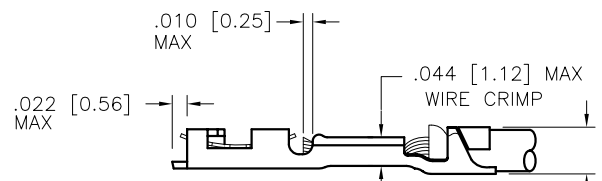

FIG. 3 RECOMMENDED CRIMP INFORMATION
.085 [2.16] WIDTH X .100 [2.54] HIGH INSULATION CRIMP MAX.

mat'l. code SEE NOTE 1 & 2				surface	tolerance	projection	product family
ltr	ecn no	dr	date	tolerances unless otherwise specified		INCH/MM	PV HOUSINGS
J				angles	linear		title
				0°±2'		scale 3:1	MINI ROD HSG SR 18 AWG .100 [2.54] CC WITH RODS
		dr	S. ROYER	1996-01-22			dwg no
		enrg	T. HANNA	1996-01-22			sheet 2 of 2
		chr	T. BREWBAKER	1996-01-22			size
		appd	T. HANNA	1996-01-22			A3
sheet	revision						type
index	sheet						Product Customer Drawing



Copyright FCJ