

NOTICE OF PROPRIETARY RIGHTS THIS DOCUMENT CONTAINS CONFIDENTIAL DATA, INCLUDING TRADE SECRETS, PROPRIETARY TO TIMES MICROWAVE SYSTEMS. DISCLOSURE OF THIS DATA IS EXPRESSLY CONDITIONED UPON YOUR ASSENT THAT ITS USE IS LIMITED TO USE WITHIN YOUR COMPANY ONLY. ANY OTHER USE IS STRICTLY PROHIBITED WITHOUT THE PRIOR WRITTEN CONSENT OF TIMES MICROWAVE SYSTEMS.

SYM	REVISION DESCRIPTION	DFTM	DATE	APPD	APPD
A	RELEASED FOR PRODUCTION	Patrick	2019/04/19	Joslen	2019/04/19

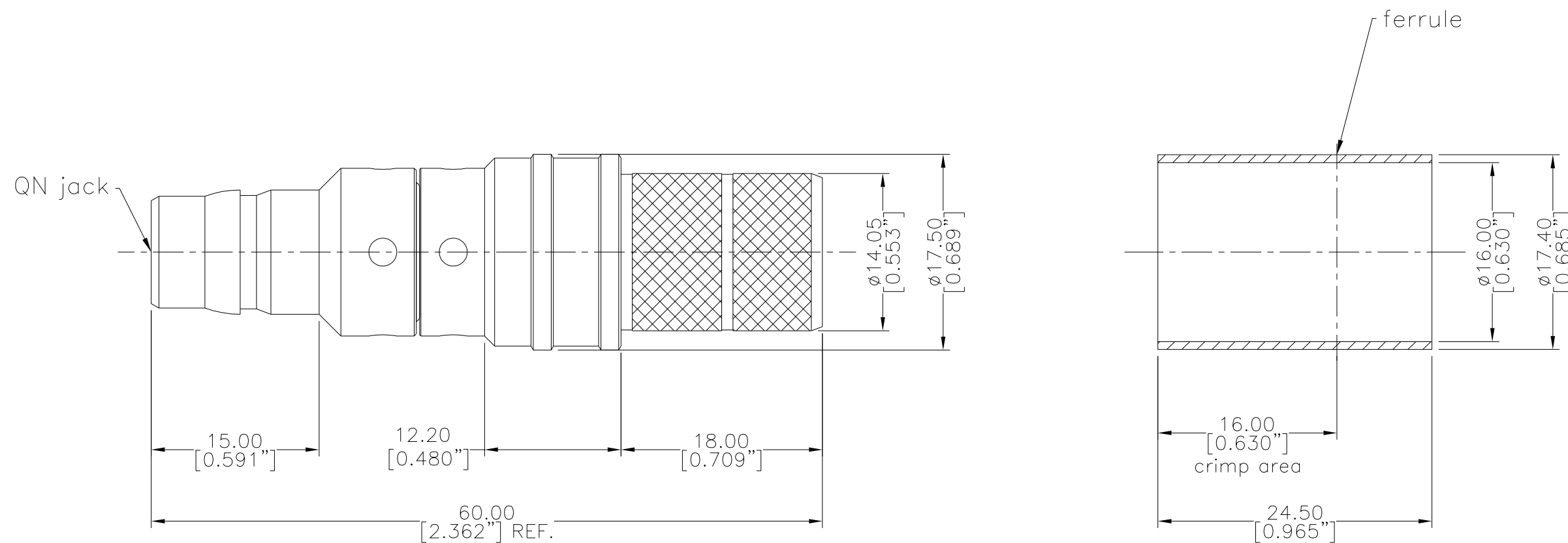

I. MATERIALS & FINISHES

Components	Materials	Finishes	Thk. (μ")
Body	Brass	Sn-Ni	100
Contact Pin	Beryllium Copper	Gold	50
Insulator	PTFE	--	--
Ferrule	Copper	Sn-Ni	100

II. ELECTRICAL PROPERTIES

Impedance:	50 Ω
Frequency Range:	DC to 6 GHz
Dielectric Withstanding Voltage:	2000 V rms
Insulation Resistance:	≥10000 MΩ
VSWR:	≤1.30
Insertion Loss:	-0.1x√f(GHz) dB

III. ENVIRONMENTAL PROPERTIES

Temperature Range:	-40°C to +125°C
Thermal Shock:	MIL-STD-202, Meth.107, Cond. B
Vibration:	IEC 1169-1 Para. 9.3.3 (10-500 Hz; 5 g)
Shock:	MIL-STD-202, Meth.213, Cond. I
Climatic Class:	IEC 60068 40/125/21
RoHS:	Compliant

IV. MECHANICAL PROPERTIES

Center Contact:	Spring Finger
Outer Contact:	Crimp
Coupling Nut Torque:	N/A
Cbl-Connector Retention Force:	200 lbs
Durability:	100 Cycles

V. TOOLINGS & ACCESSORIES

Stripping Tool:	3192-052/ CST-600
Crimping Tool:	3192-170/ CT-600
Heat Shrink Tube:	1"x2" (3:1) 1 pcs
WSB Boot Option:	3109-401/ WSB-600

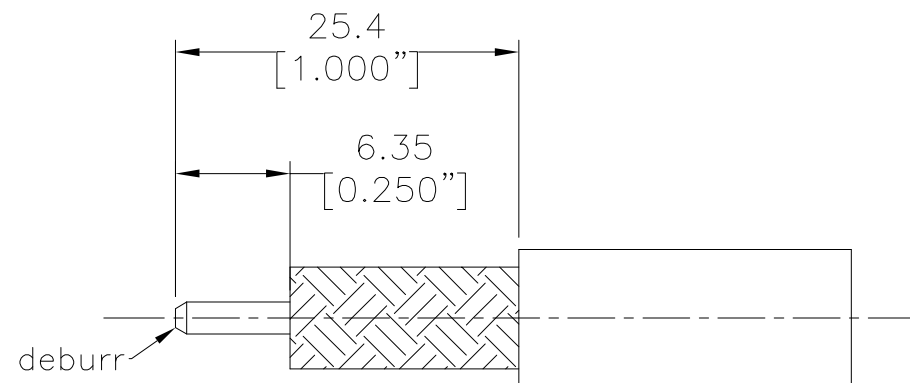

RECOMMENDED CABLE STRIPPING DIM'S
Connector Adds: 36.95 mm

Interface Compatible with Standard:
QLF®

MATL:	UNLESS OTHERWISE SPECIFIED	DFTM. Patrick	TIMES MICROWAVE SYSTEMS An Amphenol Company				
	ALL DIMENSIONS ARE IN mm MACHINED SURFACES FINISH 1.6 RMS MAX. REMOVE ALL BURRS 0.15X45° MAX. BREAK MACHINE CORNERS 0.15X45° D MAX. FILLET R. TOLERANCES ON DECIMALS .X ±0.3 .XX ±0.15 ANGLES ±2° FRACTIONS ± N/A	DATE 2019/04/19	EZ-600-QNF-X QN Female (Jack) Straight Non-Solder Pin No Braid Trim Connector for LMR-600 Cable				
		CHKD Monica					
		DATE 2019/04/19					
USED ON: O		APPD Joslen					
SCALE: N/A	DWG SIZE A3	DO NOT SCALE DRAWING	CODE IDENT 68999	DATE 2019/04/19	SHT 1/1	3190-8050	REV A