

REVISIONS					
P	LTR	DESCRIPTION	DATE	DWN	APVD
A		REVISED PER ECR-20-009840	22JUL2020	ED	RS

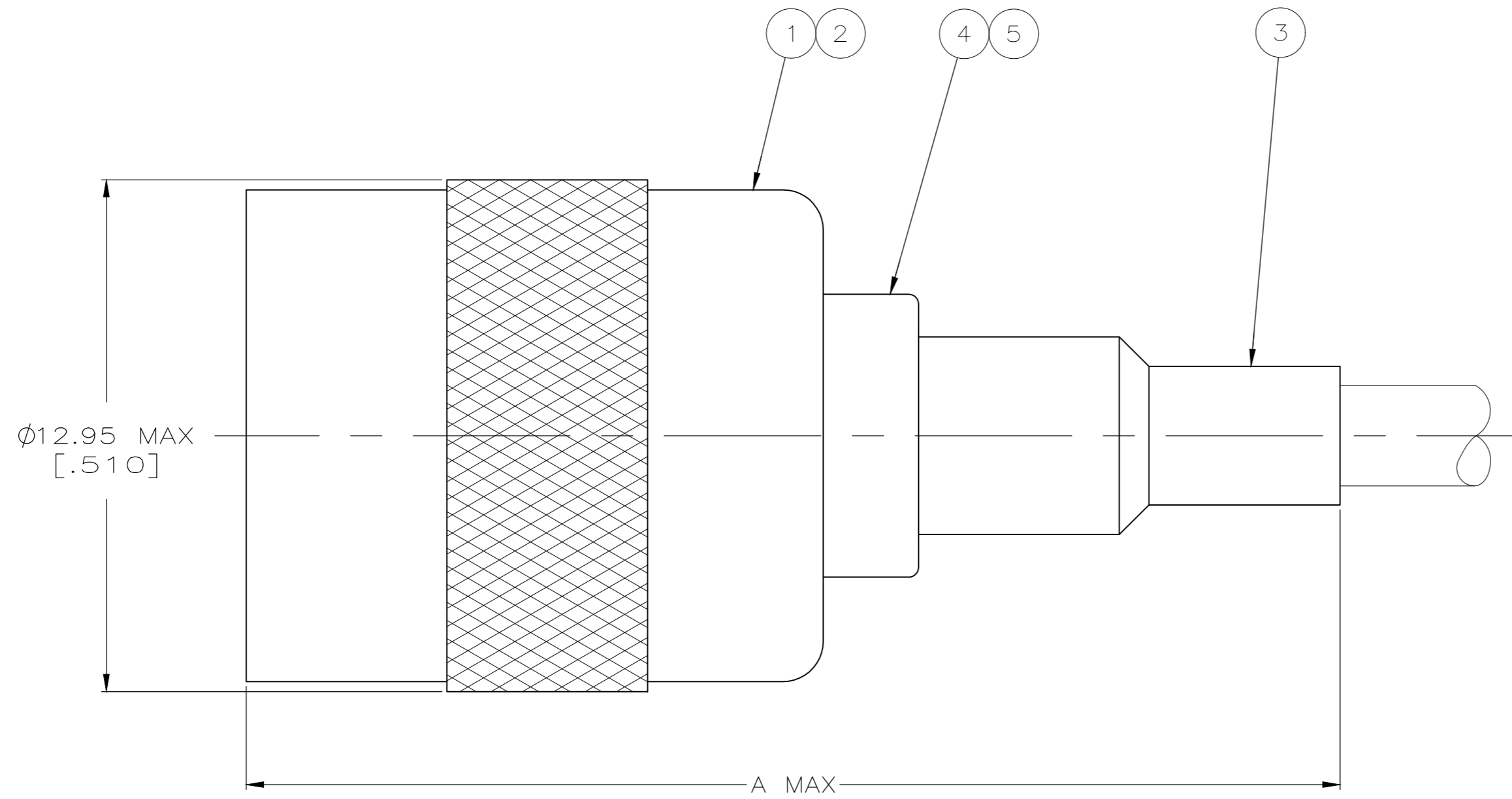

- 1. USE CRIMP TOOL 220190-1
- 2. USE INSTRUCTION SHEET 9540

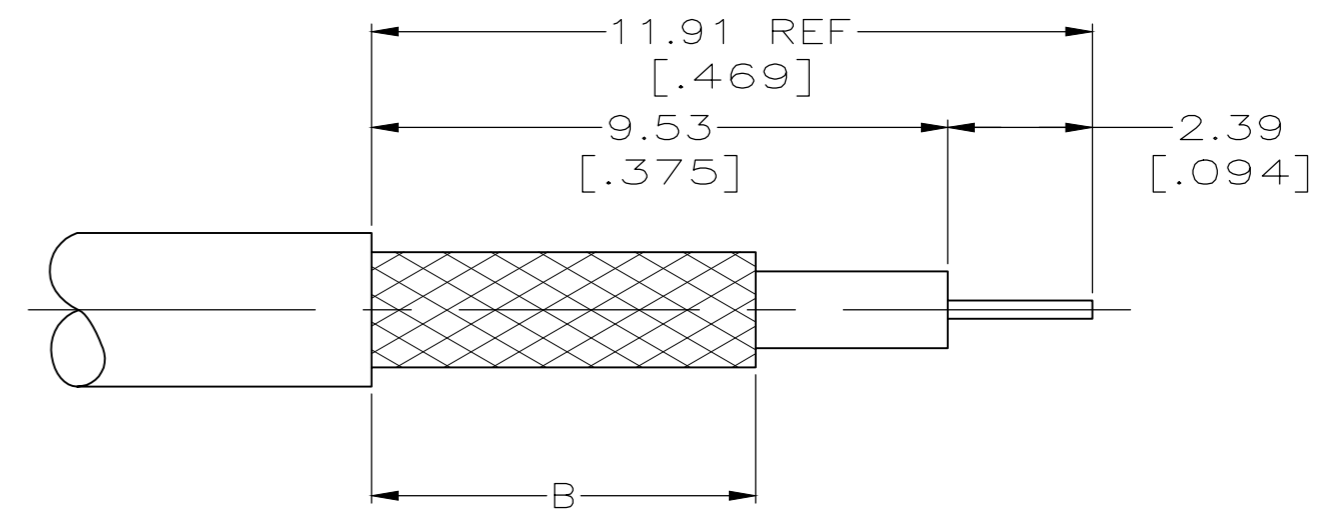

RECOMMENDED STRIP LENGTH

OBSOLETE	BELDEN 89248	6.35 [.250]	34.80 [1.370]	58086-1	-	-	9-50427-0	221182-8	221505-4	5221506-6
OBSOLETE	AT&T 735A	6.35 [.250]	29.46 [1.160]	58174-1	-	-	9-328666-2	221182-6	221505-3	5221506-5
OBSOLETE	RG-179/U, 179A, 179B, 187/U, 187A	6.35 [.250]	29.46 [1.160]	58304-1	227194-2	222001-2	9-328666-0	1-221182-2	221505-3	5221506-3
OBSOLETE	BELDEN 9231, 8281	9.53 [.375]	34.29 [1.350]	220189-7	-	-	9-50427-2	1-221182-0	221505-2	5221506-2
	FOR USE WITH CABLE	B	A	DIE SET	5 TUBING, PLASTIC QTY=1	4 TUBING QTY=1	3 FERRULE QTY=1	2 CONTACT QTY=1	1 PLUG ASSEMBLY QTY=1	PART NUMBER

THIS DRAWING IS A CONTROLLED DOCUMENT.

DIMENSIONS: mm [INCHES]	TOLERANCES UNLESS OTHERWISE SPECIFIED:	DWN J. HAVENER 24JAN2005	 TE Connectivity
	0 PLC ± -	CHK J. HAVENER 26JAN2005	
	1 PLC ± -	APVD J. LIPPERT 26JAN2005	
	2 PLC ± 0.41 [.016]	PRODUCT SPEC	
	3 PLC ± -	APPLICATION SPEC	NAME
	4 PLC ± -	FINISH	PLUG 75 OHM, COMMERCIAL TNC
MATERIAL	FINISH	WEIGHT 0.000000	SIZE A2
		CUSTOMER DRAWING	CAGE CODE 00779
			DRAWING NO 5221506
			RESTRICTED TO
			SCALE 8:1
			SHEET 1 of 1
			REV A