



# Optical XFP 10G

## Overview

Integra manufactures the highest quality XFP transceivers in the industry, designed to be 100% interoperable with all OEM platforms. We're the first optics manufacturer in the Western Hemisphere to invest in high-speed robots, allowing us to scale our operations to handle virtually any order, large or small, and ensure every transceiver is correctly coded and tested 100% of the time.

Simply search the requested OEM part number and add the suffix -IO. For example, Cisco Part # XFP-10G-MM-SR = Integra Part # XFP-10G-MM-SR-IO.

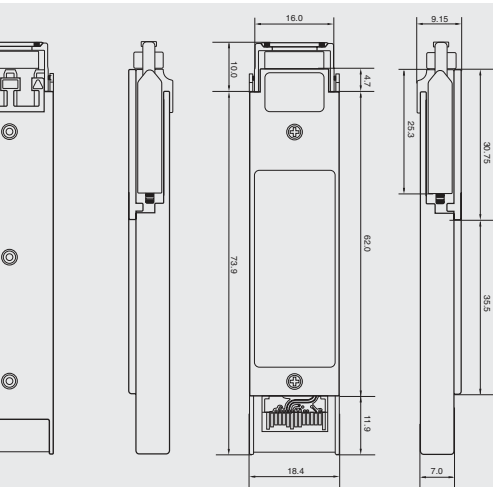

## Features

- ➔ Operating Data Rate up to 11.3Gbps
- ➔ Distance Ranging from 300m to 100km
- ➔ MMF or SMF Duplex LC Connector Interface
- ➔ Commercial, Extended & Industrial Temperatures Available
- ➔ Digital Diagnostics Monitoring
- ➔ XFP MSA Compliant

## Applications

- ➔ 10GBase-SR, 10GBase-LR, 10GBase-ER, 10GBase-ZR, 10Base-EZR
- ➔ Metro-Ethernet, Data Center, and Enterprise Networks
- ➔ SONET/SDH
- ➔ Multi-Rate Fibre Channel and CPRI
- ➔ OTN and Other Optical Links

## Detailed Specifications

Description	Wavelength (nm)	Distance (km)	Budget (dB)	TX Min/Max (dBm)	Rx Sensitivity (dBm)	Fiber Type
XFP 10GBase-SR	850	0.3	3.8	-7.3/-1	-11.1	MMF/LC
XFP 10GBase-LR	1310	10	8.5	-6/0	-14.5	SMF/LC
XFP 10GBase-ER	1310	40	16	0/4	-16	SMF/LC
XFP 10GBase-ER	1550	40	16	0/4	-16	SMF/LC
XFP 10GBase-ZR	1550	80	24	0/4	-24	SMF/LC
XFP 10GBase-EZR	1550	100	25	0/5	-25	SMF/LC

For more information on OEM support please go to [www.IntegraOptics.com](http://www.IntegraOptics.com)

## Did You Know?

You can ensure coding accuracy and eliminate time spent finding replacement optics when you choose Integra transceivers. Our Smart Coder allows technicians to reconfigure our transceivers for specific hardware right in the field.

## Our Mission

---

Our mission is to ensure that our customers turn up services faster, build out the fiber networks they need to be competitive, and keep them up and running.

## Our Process and Commitment to Uptime

---



Integra Optics is leading the way in uptime. We're innovating the transceiver manufacturing process for more reliable optics and increased availability, from product concept to customer service. We back all of our transceivers with a limited lifetime warranty, and we have designed our process to get the very best transceivers to our customers faster than ever before.

- ➔ **Designed for interoperability:** Integra brand transceivers designed and programmed to be 100% interoperable with OEM platform hardware and fully comply with OEM equipment warranties
- ➔ **Automated production:** Automated production process in our US facility, using the first high-speed robots in the Western Hemisphere for coding and testing transceivers
- ➔ **Accurate coding:** Every transceiver is correctly coded and tested 100% of the time, resulting in optics that are 33 times more reliable than both OEM and third party generics
- ➔ **On-demand availability:** We maintain the largest inventory of transceivers in the Western Hemisphere to fill transceiver orders in days rather than the weeks or months, and help customers manage their supply chains.
- ➔ **24-hour support:** Experienced customer support team, available 24-hours a day, for technical support and equipment orders
- ➔ **A responsive organization:** Unmatched customer service, next-day shipping and even private aircraft to respond to our customers' needs
- ➔ **Experienced engineers:** Vast industry experience to help troubleshoot problems, consult on network design solutions and help with turn up
- ➔ **ISO Certified:** We hold the ISO 9001:2008 Quality Management System Certification for our dedication to quality in every step of our processes

## Additional Information

---

For more information about XFP 10G please contact a sales representative at [sales@integraoptics.com](mailto:sales@integraoptics.com) or visit [integraoptics.com](http://integraoptics.com)