

FEATURES

- Efficiency >95%**
- Input voltage range: 2.7 V to 5.5 V**
- Output voltage range: 0.8 V to V_{IN}**
- Maximum output current: 1.5 A**
- Switching frequency: 1.2 MHz**
- Quiescent current: 20 μ A**
- Shutdown current: 0.1 μ A**
- Enable/shutdown logic input**
- Optimized for small ferrite core inductors**
- Optimized for tiny ceramic input and output capacitors**
- Programmable soft start with single capacitor**
- Programmable compensation for optimizing transient performance with a resistor and a capacitor**

GENERAL DESCRIPTION

The ADP2106 evaluation board is a complete step-down dc-to-dc converter solution using the ADP2106 step-down dc-to-dc converter. It provides a $\pm 1\%$ accurate ($\pm 3\%$ over all conditions) regulated output voltage with load currents up to 1.5 A. It comes in two versions: the ADP2106-1.8-EVAL with fixed output voltage of 1.8 V, and the ADP2106-EVAL with adjustable output voltage initially set to 2.5 V.

The ADP2106 is a synchronous, step-down dc-to-dc converter that uses a current-mode pulse width modulation (PWM) control scheme at medium-to-heavy load currents for high efficiency, but smoothly transitions to a pulse frequency modulation (PFM) scheme at light loads to conserve power. The power switch and synchronous rectifier are integrated for minimal external part count and high efficiency. The ADP2106 has been optimized for operation with small ferrite core inductors and tiny ceramic capacitors to deliver the maximum output power per square inch of the PCB board area.

For more details, see the [ADP2106](#) data sheet.

FUNCTIONAL BLOCK DIAGRAM

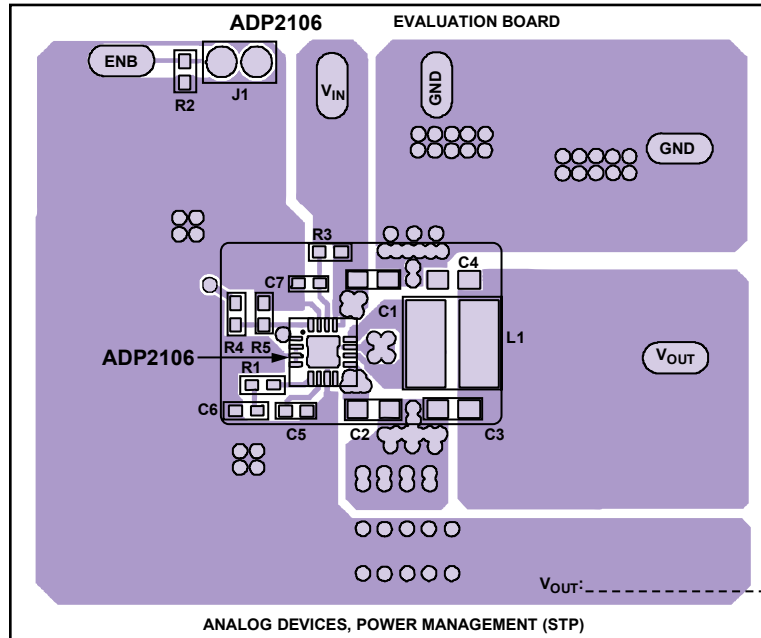

Figure 1.

Rev. 0

Evaluation boards are only intended for device evaluation and not for production purposes. Evaluation boards as supplied "as is" and without warranties of any kind, express, implied, or statutory including, but not limited to, any implied warranty of merchantability or fitness for a particular purpose. No license is granted by implication or otherwise under any patents or other intellectual property by application or use of evaluation boards. Information furnished by Analog Devices is believed to be accurate and reliable. However, no responsibility is assumed by Analog Devices for its use, nor for any infringements of patents or other rights of third parties that may result from its use. Analog Devices reserves the right to change devices or specifications at any time without notice. Trademarks and registered trademarks are the property of their respective owners. Evaluation boards are not authorized to be used in life support devices or systems.

TABLE OF CONTENTS

Features	1	Modifying the Evaluation Board	4
General Description	1	Measurement Setup	5
Functional Block Diagram	1	Typical Performance Characteristics	6
Revision History	2	Ordering Information	7
Using the Evaluation Board.....	3	Bill of Materials.....	7
Powering Up the Evaluation Board.....	3	Ordering Guide	9
Measuring Evaluation Board Performance	3	ESD Caution.....	9

REVISION HISTORY

1/07—Revision 0: Initial Version

USING THE EVALUATION BOARD

POWERING UP THE EVALUATION BOARD

The ADP2106 evaluation board is supplied fully assembled and tested. Before applying power to the evaluation board, follow the procedures outlined in this section.

Jumper J1

Before turning on the ADP2106 evaluation board, make sure that all the components are present, but that Jumper J1 is removed.

Input Power Source

Before connecting the power source to the ADP2106 evaluation board, make sure that it is turned off. If the input power source includes a current meter, use that meter to monitor the input current. Connect the positive terminal of the power source to the V_{IN} terminal on the evaluation board, and the negative terminal of the power source to the GND terminal of the evaluation board. If the power source does not include a current meter, connect a current meter in series with the input source voltage. Connect the positive lead (+) of the power source to the ammeter positive (+) connection, the negative lead (-) of the power source to the GND terminal on the evaluation board, and the negative lead (-) of the ammeter to the V_{IN} terminal on the board.

Output Load

Although the ADP2106 evaluation board can sustain the sudden connection of the load, it is possible to damage the load if it is not properly connected. Make sure that the board is turned off before connecting the load. If the load includes an ammeter, or if the current is not measured, connect the load directly to the evaluation board with the positive (+) load connection to the V_{OUT} terminal and the negative (-) load connection to the GND terminal. If an ammeter is used, connect it in series with the load; connect the positive (+) ammeter terminal to the evaluation board V_{OUT} terminal, the negative (-) ammeter terminal to the positive (+) load terminal, and the negative (-) load terminal to the evaluation board GND terminal. Once the load is connected, make sure that it is set to the proper current before powering the ADP2106 evaluation board.

Input and Output Voltmeters

Measure the input and output voltages with voltmeters. Make sure that the voltmeters are connected to the appropriate evaluation board terminals and not to the load or power source themselves. If the voltmeters are not connected directly to the evaluation board, the measured voltages are incorrect due to the voltage drop across the leads and/or connections between the evaluation board, the power source, and/or the load.

Connect the input voltage measuring voltmeter positive terminal (+) to the evaluation board V_{IN} terminal and the negative (-) terminal to the evaluation board GND terminal. Connect the output voltage measuring voltmeter positive (+) terminal to the evaluation board V_{OUT} terminal and the negative (-) terminal to the evaluation board GND terminal.

Turning On the Evaluation Board

Once the power source and load are connected to the ADP2106 evaluation board, it can be powered for operation. Slowly increase the input power source voltage until the input voltage exceeds the minimum input operating voltage of 2.7 V. Insert Jumper J1 and check to see if the output voltage rises to the regulated output voltage (1.8 V for the ADP2106-1.8-EVAL and 2.5 V for the ADP2106-EVAL). If the load is not already enabled, enable the load, and check that it is drawing the proper current and that the output voltage maintains voltage regulation.

MEASURING EVALUATION BOARD PERFORMANCE

Measuring Output Voltage Ripple

To observe the output voltage ripple, place an oscilloscope probe across the output capacitor (C3/C4) with the probe ground lead at the negative (-) capacitor terminal and the probe tip at the positive (+) capacitor terminal. Set the oscilloscope to ac, 20 mV/division, and 2 μ s/division time base.

In the PWM mode of operation, the output voltage ripple must be small (<20 mV), but in PFM mode, the output voltage ripple can be as large as 50 mV.

Measuring the Switching Waveform

To observe the switching waveform with an oscilloscope, place the oscilloscope probe tip at the end of the inductor that is connected to the LX pins with the probe ground at GND. Set the scope to dc, 2 V/division, and 2 μ s/division time base. The switching waveform should alternate between 0 V and the approximate input voltage.

Measuring Load Regulation

Load regulation must be tested by increasing the load at the output and looking at the change in output voltage. To minimize voltage drop, use short low resistance wires, especially for heavy loads.

Measuring Line Regulation

Vary the input voltage and examine the change in the output voltage.

Measuring Efficiency

The efficiency, η , is measured by comparing the input power with the output power.

$$\eta = \frac{V_{OUT} \times I_{OUT}}{V_{IN} \times I_{IN}}$$

Measure the input and output voltages as close as possible to the input and output capacitors to reduce the effect of IR drops.

Measuring Inductor Current

The inductor current can be measured by removing one end of the inductor from its pad and connecting a current loop in series with it. Then a current probe can be used to measure the current flowing through the current loop, as shown in Figure 2.

MODIFYING THE EVALUATION BOARD

The ADP2106 evaluation board is supplied fully assembled and tested for proper operation. It comes in two versions: the ADP2106-1.8-EVAL with fixed output voltage of 1.8 V and the ADP2106-EVAL with adjustable output voltage initially set to 2.5 V.

The two most common modifications that can be done to the evaluation boards are changing the output voltage and changing the load transient response.

Changing the Output Voltage

The ADP2106-EVAL output regulation voltage can be changed by altering its external components. The ADP2106-1.8-EVAL output regulation voltage is fixed at 1.8 V and cannot be changed.

The ADP2106-EVAL output regulation voltage is set by a resistive voltage divider consisting of Resistor R4 and Resistor R5. Resistor R4 corresponds to the R_{TOP} resistor in the [ADP2106](#) data sheet, and Resistor R5 corresponds to the R_{BOT} resistor in the ADP2106 data sheet. The output regulation voltage is determined by the equation

$$V_{OUT} = 0.8 \text{ V} \times \left[\frac{R_{TOP} + R_{BOT}}{R_{BOT}} \right]$$

where:

R_{TOP} is the value of the top resistor of the voltage divider (R4).
 R_{BOT} is the value of the bottom resistor of the voltage divider (R5).
 V_{OUT} is the output regulation voltage in volts.

To set the output regulation voltage to the desired value, first determine the value of the bottom resistor, R_{BOT} , by

$$R_{BOT} = \frac{V_{FB}}{I_{STRING}}$$

where:

$V_{FB} = 0.8 \text{ V}$, the internal reference.

I_{STRING} is the resistor divider string current (20 μA nominally)

Once R_{BOT} is determined, calculate the value of the top resistor, R_{TOP} , from

$$R_{TOP} = R_{BOT} \left[\frac{V_{OUT} - V_{FB}}{V_{FB}} \right]$$

For example, to set the output regulation voltage of ADP2106-EVAL to 2.0 V, calculate the value of Resistor R4 and Resistor R5 as shown below.

$$R5 = \frac{V_{FB}}{I_{STRING}} = \frac{0.8 \text{ V}}{20 \mu\text{A}} = 40 \text{ k}\Omega$$

$$R4 = R5 \times \left[\frac{V_{OUT} - V_{FB}}{V_{FB}} \right] = 40 \text{ k}\Omega \times \left[\frac{2 \text{ V} - 0.8 \text{ V}}{0.8 \text{ V}} \right] = 60 \text{ k}\Omega$$

Note that when the output voltage of ADP2106-EVAL is changed, the output capacitors (C3 and C4), inductor (L1), and compensation components (R1 and C6) are recalculated and changed according to the Application Information section in the ADP2106 data sheet to ensure stable operation.

Changing the Load Transient Response

The ADP2106 evaluation board load transient response can be altered by changing the output capacitors (C3 and C4) and the compensation components (R1 and C6) as explained in the Output Capacitor Selection and Loop Compensation sections of the ADP2106 data sheet. By default, the load transient response of both ADP2106 evaluation boards is set to 5% of the output voltage for a 1 A load transient.

Consider an example where the load transient response of the ADP2106-1.8-EVAL is changed to 10% of the output voltage for a 1 A load transient.

First, select the output capacitors (C3 and C4) based on the load transient response requirements. The desired load transient response is 10% overshoot for a 1 A load transient. For this condition, the % Overshoot for a 1 A Load Transient Response vs. Output Capacitor \times Output Voltage figure in the ADP2106 data sheet gives

$$\begin{aligned} \text{Output Capacitor} \times \text{Output Voltage} &= 25 \mu\text{C} \\ \Rightarrow \text{Output Capacitor} &= \frac{25 \mu\text{C}}{1.8 \text{ V}} \approx 14 \mu\text{F} \end{aligned}$$

Next, taking into account the loss of capacitance due to dc bias as shown in the % Drop-In Capacitance vs. DC Bias for Ceramic Capacitors figure in the ADP2106 data sheet, let C3 and C4 be two 10 μF X5R MLCC capacitors (GRM21BR61A106KE19L).

Finally, calculate the compensation resistor and compensation capacitor as follows:

$$\begin{aligned} R_{COMP} &= 0.8 \left(\frac{(2\pi)F_{CROSS}}{G_m G_{CS}} \right) \times \left(\frac{C_{OUT} V_{OUT}}{V_{REF}} \right) \\ &= 0.8 \left(\frac{(2\pi) \times 80 \text{ kHz}}{50 \mu\text{A/V} \times 2.8125 \text{ A/V}} \right) \times \left(\frac{14 \mu\text{F} \times 1.8 \text{ V}}{0.8 \text{ V}} \right) = 90 \text{ k}\Omega \\ C_{COMP} &= \frac{2}{\pi F_{CROSS} R_{COMP}} = \frac{2}{\pi \times 80 \text{ kHz} \times 90 \text{ k}\Omega} = 90 \text{ pF} \end{aligned}$$

Therefore, choose the compensation resistor to be 90 k Ω and the compensation capacitor to be 100 pF.

MEASUREMENT SETUP

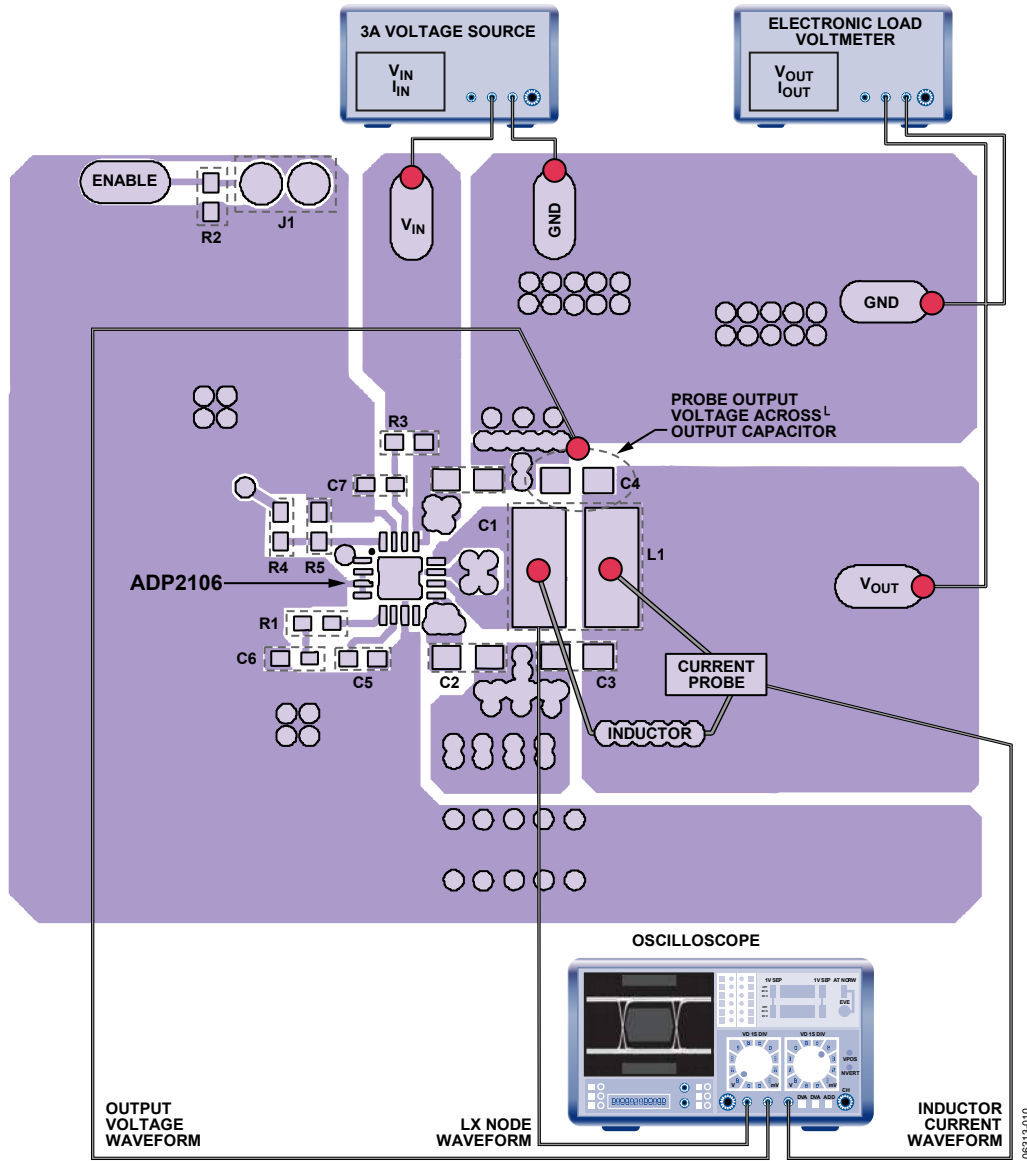

Figure 2. Typical Measurement Setup

TYPICAL PERFORMANCE CHARACTERISTICS

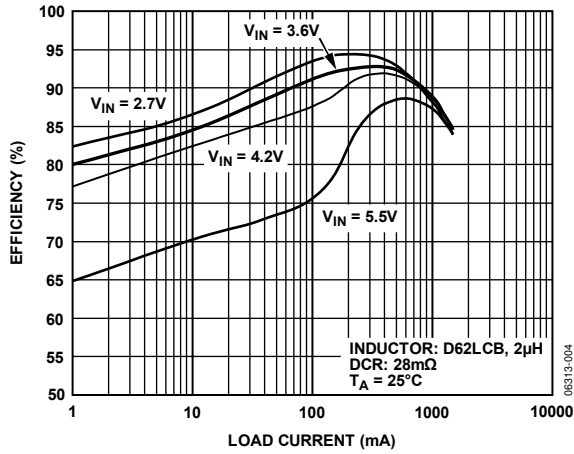

Figure 3. Efficiency—ADP2106-1.8-EVAL (1.8 V Output)

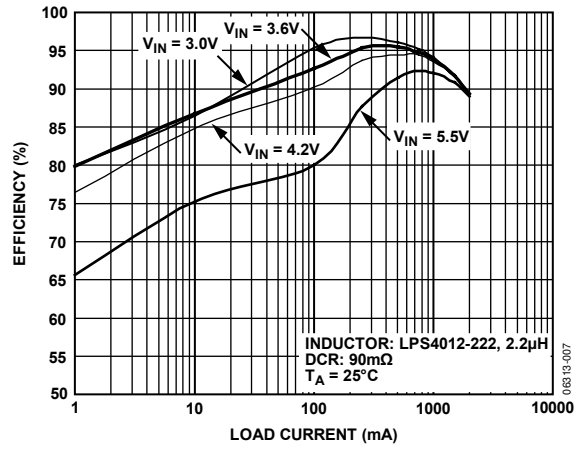

Figure 6. Efficiency—ADP2106-EVAL (2.5 V Output)

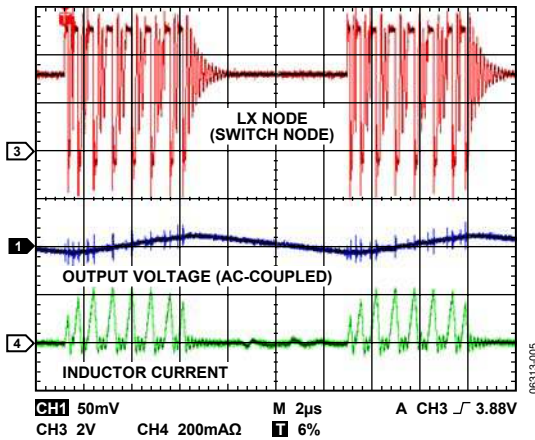

Figure 4. PFM Mode of Operation at Light Load (10 mA)

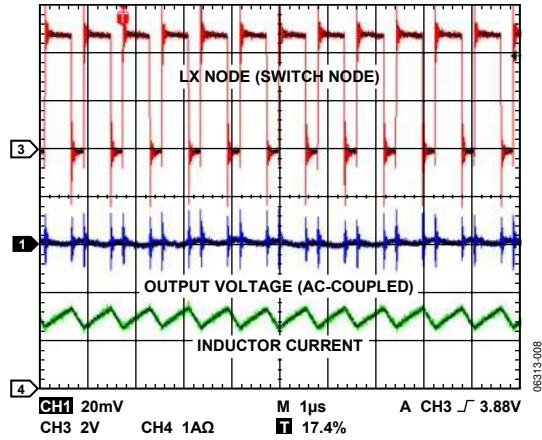

Figure 7. PWM Mode of Operation at Medium/Heavy Load (1 A)

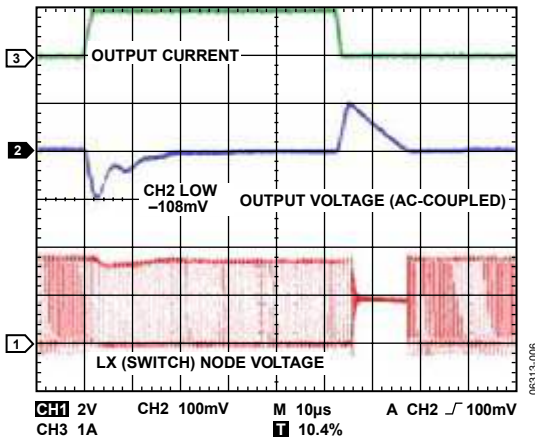

Figure 5. 1 A Load Transient Response for ADP2106-1.8-EVAL

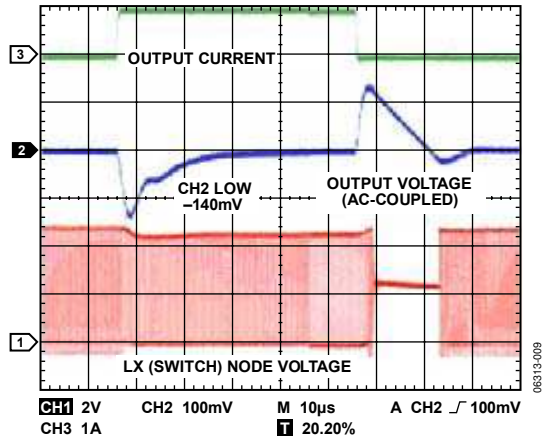

Figure 8. 1 A Load Transient Response for ADP2106-EVAL with V_{OUT} Set to 2.5 V

ORDERING INFORMATION

BILL OF MATERIALS

Table 1. Bill of Materials for ADP2106-1.8-EVAL with V_{OUT} Set to 2.5 V

Description	Reference Designator	Reference Name ¹	Qty.	Manufacturer	Part Number
Capacitor, MLCC, 4.7 μ F, 10 V, 0805, X5R, SMD	C1	C_{IN1}	1	Murata	GRM21BR61A475KA73L
Capacitor, MLCC, 10 μ F, 10 V, 0805, X5R, SMD	C2	C_{IN2}	1	Murata	GRM21BR61A106KE19L
Capacitor, MLCC, 22 μ F, 6.3 V, 0805, X5R, SMD	C3, C4	C_{OUT}	2	Murata	GRM21BR60J226ME39L
Capacitor, MLCC, 1 nF, 16 V, 0603, X7R, SMD	C5	C_{SS}	1	Vishay Vitramon or equivalent	VJ0603Y102KXJA
Capacitor, MLCC, 56 pF, 50 V, 0603, NPO	C6	C_{COMP}	1	Vishay Vitramon or equivalent	VJ0603Y560KXJA
Capacitor, MLCC, 0.1 μ F, 25 V, 0603, X7R, SMD	C7	IN (filter capacitor)	1	Vishay Vitramon or equivalent	VJ0603Y104KXXA
Resistor, 182 k Ω , 1%, 0603, SMD	R1	R_{COMP}	1	Vishay Dale or equivalent	CRCW06031823FRT1
Resistor, 100 k Ω , 1%, 0603, SMD	R2	EN (pull down)	1	Vishay Dale or equivalent	CRCW06031003FRT1
Resistor, 10 Ω , 1%, 0603, SMD	R3	IN (filter resistor)	1	Vishay Dale or equivalent	CRCW060310R0FRT1
Resistor, 0 Ω , 1%, 0603, SMD	R4		1	Vishay Dale or equivalent	CRCW06030000ZSSF
Bottom Resistor of Voltage Divider ²	R5				
Inductor 2.2 μ H, 3.9 mm x 3.9 mm x 1.1 mm	L1	L	1	Coilcraft®	LPS4012-222
1.8 V, 1.5 A Step Down DC-to-DC Converter	U1		1	Analog Devices, Inc.	ADP2106-1.8
Headers, 0.100, Single, Straight	V_{OUT} , V_{IN} , GND, GND, J1, EN		6	Sullins Electronics or equivalent	S1012-36-NDPTC36SAAN

¹ Refer to the Typical Applications Circuit for Fixed Output Voltage Options figure in the ADP2106 data sheet.

² Do not solder this component onto the board.

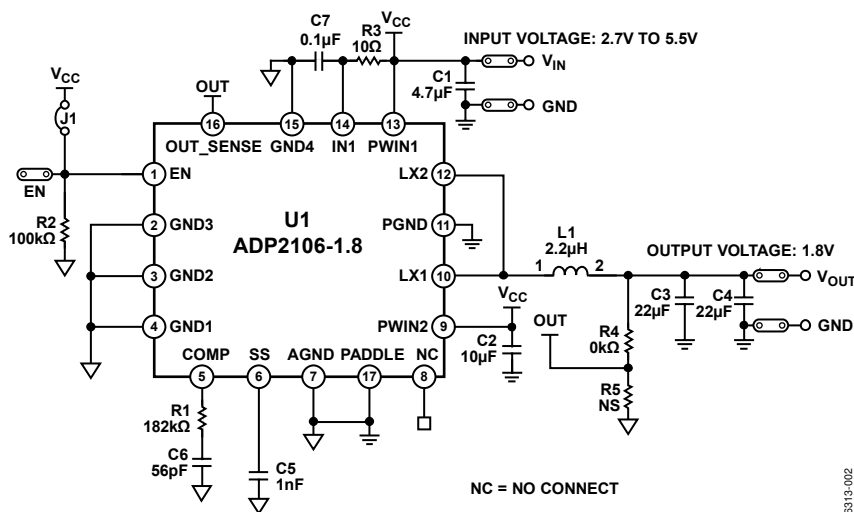

Figure 9. Evaluation Board Schematic of ADP2106-1.8-EVAL with $V_{OUT} = 1.8$ V

EVAL-ADP2106

Table 2. Bill of Materials for ADP2106-EVAL with V_{OUT} Set to 2.5 V

Description	Reference Designator	Reference Name ¹	Qty.	Manufacturer	Part Number
Capacitor, MLCC, 4.7 μ F, 10 V, 0805, X5R, SMD	C1	C_{IN1}	1	Murata	GRM21BR61A475KA73L
Capacitor, MLCC, 10 μ F, 10 V, 0805, X5R, SMD	C2	C_{IN2}	1	Murata	GRM21BR61A106KE19L
Capacitor, MLCC, 22 μ F, 6.3 V, 0805, X5R, SMD	C3	C_{OUT}	1	Murata	GRM21BR60J226ME39L
Capacitor, MLCC, 10 μ F, 10 V, 0805, X5R, SMD	C4	C_{OUT}	1	Murata	GRM21BR61A106KE19L
Capacitor, MLCC, 1 nF, 16 V, 0603, X7R, SMD	C5	C_{SS}	1	Vishay Vitramon or equivalent	VJ0603Y102KXJA
Capacitor, MLCC, 56 pF, 50 V, 0603, NPO	C6	C_{COMP}	1	Vishay Vitramon or equivalent	VJ0603Y560KXJA
Capacitor, MLCC, 0.1 μ F, 25 V, 0603, X7R, SMD	C7	IN (filter capacitor)	1	Vishay Vitramon or equivalent	VJ0603Y104KXXA
Resistor, 182 k Ω , 1%, 0603, SMD	R1	R_{COMP}	1	Vishay Dale or equivalent	CRCW06031823FRT1
Resistor, 100 k Ω , 1%, 0603, SMD	R2	EN (pull down)	1	Vishay Dale or equivalent	CRCW06031003FRT1
Resistor, 10 Ω , 1%, 0603, SMD	R3	IN (filter resistor)	1	Vishay Dale or equivalent	CRCW060310R0FRT1
Resistor, 87.6 k Ω , 0.5%, 0603, SMD	R4	R_{TOP}	1	Vishay Dale or equivalent	TNPW060387K6DHTA
Resistor, 41.2 k Ω , 0.1%, 0603, SMD	R5	R_{BOT}	1	Vishay Dale or equivalent	TNPW060341K2BEEN
Inductor 2.5 μ H, 5.2 mm x 5.2 mm x 1.4 mm	L1	L	1	Cooper Bussmann (Coiltronics)	SD14-2R5
1.5 A Step Down DC-to-DC Converter with Adjustable Output	U1		1	Analog Devices	ADP2106-ADJ
Headers, 0.100, Single, Straight	V_{OUT} , V_{IN} , GND, GND, J1, EN		6	Sullins Electronics or equivalent	S1012-36-NDPTC36SAAN

¹ Refer to the Typical Applications Circuit for Adjustable Output Voltage Option figure in the [ADP2106](#) data sheet.

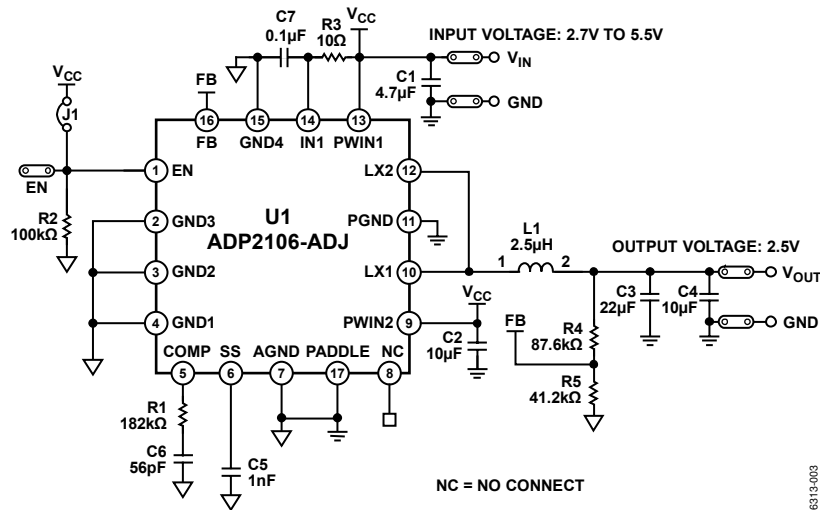

Figure 10. Evaluation Board Schematic for ADP2106-EVAL with Adjustable V_{OUT} Initially Set to 2.5 V

ORDERING GUIDE

Model	Description
ADP2106-1.8-EVAL	Evaluation board with fixed output voltage
ADP2106-EVAL	Evaluation board with adjustable output voltage

ESD CAUTION**ESD (electrostatic discharge) sensitive device.**

Charged devices and circuit boards can discharge without detection. Although this product features patented or proprietary protection circuitry, damage may occur on devices subjected to high energy ESD. Therefore, proper ESD precautions should be taken to avoid performance degradation or loss of functionality.

NOTES

NOTES

NOTES