

CONFIGURAZIONE POLARIZZAZIONI
POLARIZATION CONFIGURATION

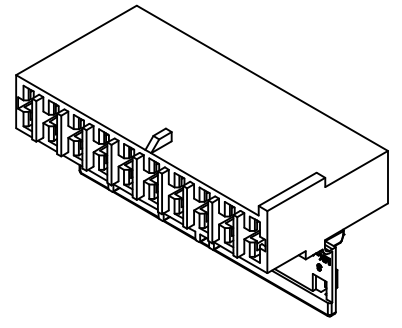
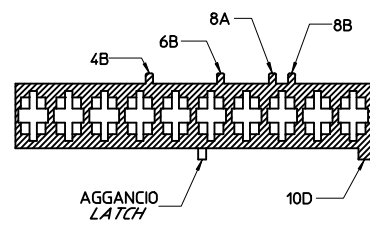

- NOTE:
- USATO CON TERMINALE 94518-0XXX E 94549-0XXX
 - SPECIFICA DI RIFERIMENTO PER IL CONNETTORE PS-94550-001
 - PER CARATTERISTICHE DI CRIMPATURA RIF. SD-94518-005 E SD-94549-001
 - FORZA DI DISACCOPIAMENTO CONNETTORE (TRAZIONANDO DAI CAVI SENZA AZIONARE L'AGGANCIAMENTO): 60 N MIN.
 - SPESSORE MINIMO PARETI CONNETTORE 0.40 mm.

SEZ: C-C

- NOTE:
- USED WITH TERMINALS 94518-0XXX AND 94549-0XXX
 - REFER TO PS-94550-001 FOR CONNECTOR SPECIFICATION
 - REFER TO SD-94518-005 FOR AND SD-94549-001 CRIMPING CHARACTERISTICS
 - CONNECTOR DISENGAGEMENT FORCE (PULLING BY THE WIRES, WITHOUT ACTUATING THE LATCH): 60 N MIN.
 - MINIMUM CONNECTOR WALL THICKNESS 0.40 mm.

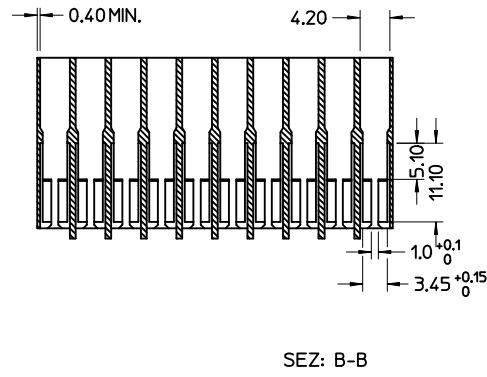

SEZ: B-B

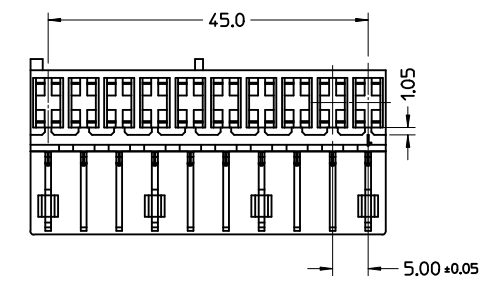
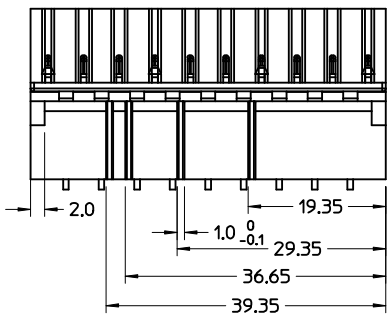
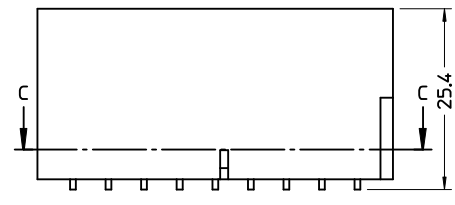
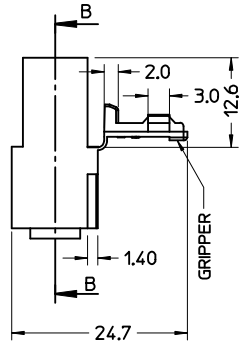

MATERIALE: NYLON 6.6 GWT 750°C SEC. IEC 60335-1
TEST METHOD IEC 60695-2-11 COLORE NATURALE
MATERIAL: NYLON 6.6 GWT 750°C SEC. IEC 60335-1
TEST METHOD IEC 60695-2-11 NATURAL
CONFEZIONE: Box da 1000 Pz.
PACKAGING: 1200 pcs in carton box

SPQ =1000 pz.

Std. Descr: 'HSG WITH RIGID LATCH 10CKT NATURAL COLOR'

EC NO: Z2008-0003 DRWIN:FGOTTARDI07/07/25 CHKD:LSANTES007/07/26 APPR:GZUIN 2007/07/26	QUALITY SYMBOLS	GENERAL TOLERANCES (UNLESS SPECIFIED)	SCALE 2:1	DESIGN UNITS METRIC	FIRST ANGLE PROJECTION	REVISE ON CAD ONLY
	▽ - 0	4 PLACES ± --- ± ---	mm INCH	DIMENSION STYLE MM ONLY	TITLE HSG 10 CKT WITH SEC.LOCK	
	▽ - 0	3 PLACES ± --- ± ---		DRAWN BY FGOTTARD 2006/05/25		
		2 PLACES ± 0.10 ± ---		CHECKED BY RSANDANO 2006/05/25		
	1 PLACE ± 0.2 ± ---	ANGULAR ± 2 °	APPROVED BY GZUIN 2006/05/25	MATERIAL NO. 94560-4010		DOCUMENT NO. SD-94560-001
		DRAFT WHERE APPLICABLE	THIS DRAWING CONTAINS INFORMATION THAT IS PROPRIETARY TO MOLEX INCORPORATED AND SHOULD NOT BE USED WITHOUT WRITTEN PERMISSION		SHEET NO. 1 OF 1	
		MUST REMAIN WITHIN DIMENSIONS			A2	

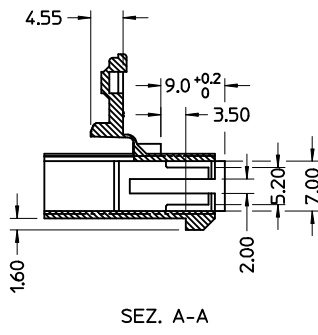
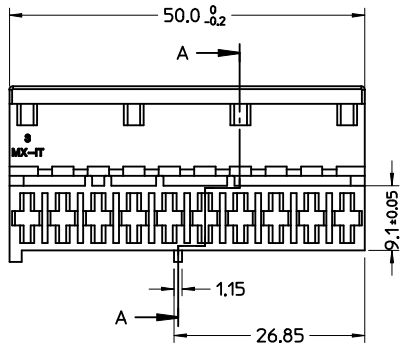

CONFIGURAZIONE POLARIZZAZIONI
POLARIZATION CONFIGURATION

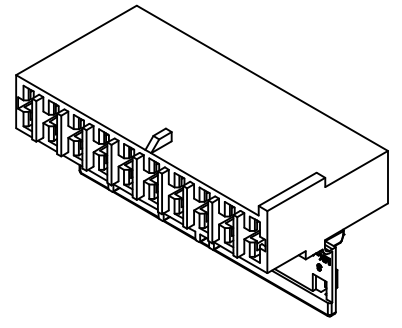
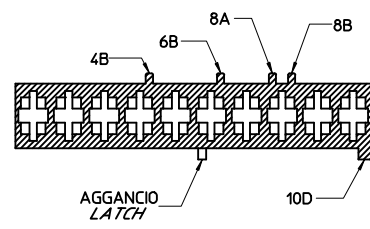

- NOTE:
- USATO CON TERMINALE 94518-0XXX E 94549-0XXX
 - SPECIFICA DI RIFERIMENTO PER IL CONNETTORE PS-94550-001
 - PER CARATTERISTICHE DI CRIMPATURA RIF. SD-94518-005 E SD-94549-001
 - FORZA DI DISACCOPIAMENTO CONNETTORE (TRAZIONANDO DAI CAVI SENZA AZIONARE L'AGGANCIAMENTO): 60 N MIN.
 - SPESSORE MINIMO PARETI CONNETTORE 0.40 mm.

SEZ: C-C

- NOTE:
- USED WITH TERMINALS 94518-0XXX AND 94549-0XXX
 - REFER TO PS-94550-001 FOR CONNECTOR SPECIFICATION
 - REFER TO SD-94518-005 FOR AND SD-94549-001 CRIMPING CHARACTERISTICS
 - CONNECTOR DISENGAGEMENT FORCE (PULLING BY THE WIRES, WITHOUT ACTUATING THE LATCH): 60 N MIN.
 - MINIMUM CONNECTOR WALL THICKNESS 0.40 mm.

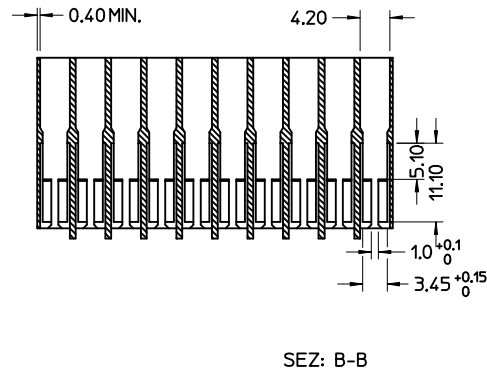

SEZ: B-B

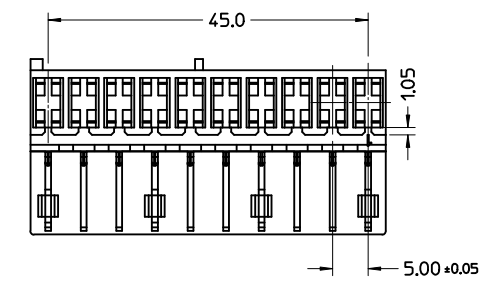
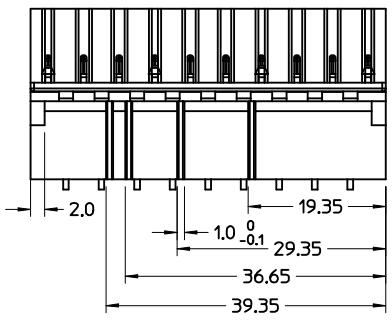
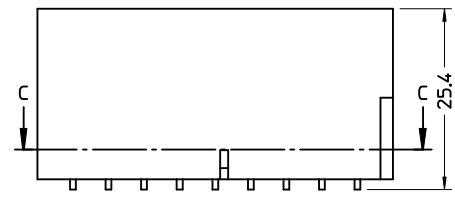
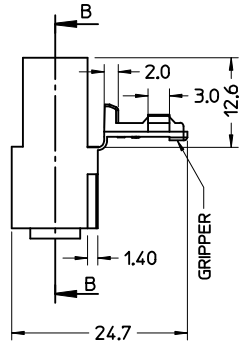

MATERIALE: NYLON 6.6 GWT 750°C SEC. IEC 60335-1
TEST METHOD IEC 60695-2-11 COLORE NATURALE
MATERIAL: NYLON 6.6 GWT 750°C SEC. IEC 60335-1
TEST METHOD IEC 60695-2-11 NATURAL
CONFEZIONE: Box da 1000 Pz.
PACKAGING: 1200 pcs in carton box

SPQ =1000 pz.

Std. Descr: 'HSG WITH RIGID LATCH 10CKT NATURAL COLOR'

IEC NO: Z2008-0003 DRWIN:FGOTTARDI07/07/25 CHKD:LSANTES007/07/26 APPR:GZUIN 2007/07/26	DESCRIPTION HSG WITH RIGID LATCH 10CKT NATURAL COLOR	QUALITY SYMBOLS	GENERAL TOLERANCES (UNLESS SPECIFIED)	SCALE 2:1	DESIGN UNITS METRIC	FIRST ANGLE PROJECTION	REVISE ON CAD ONLY
		▽ - 0 ▽ - 0	mm INCH 4 PLACES ± --- ± --- 3 PLACES ± --- ± --- 2 PLACES ± 0.10 ± --- 1 PLACE ± 0.2 ± ---	DIMENSION STYLE MM ONLY		TITLE HSG 10 CKT WITH SEC.LOCK	
		DRAFT WHERE APPLICABLE MUST REMAIN WITHIN DIMENSIONS	DRAWN BY FGOTTARD 2006/05/25 CHECKED BY RSANDANO 2006/05/25 APPROVED BY GZUIN 2006/05/25	MATERIAL NO. 94560-4010		DOCUMENT NO. SD-94560-001	SHEET NO. 1 OF 1
		THIS DRAWING CONTAINS INFORMATION THAT IS PROPRIETARY TO MOLEX INCORPORATED AND SHOULD NOT BE USED WITHOUT WRITTEN PERMISSION					