

This version (26 Jan 2018 10:40) was *approved* by RAnslow. The Previously approved version (26 Jan 2018 10:36) is available. 🇺🇸

## -Table of Contents

- EVAL-ADM2795EARDZ Arduino Shield
  - Connectors and Jumper Configurations
    - Joystick
    - Ultrasound
    - Terminal Block
  - Isolated Motor Control System using Arduino Form Factor Rapid Development Platforms
  - Schematic, Bill of Materials, Gerber Files and Layout Files
  - Change Log
  - Resources
  - Software

# EVAL-ADM2795EARDZ Arduino Shield

Use the EVAL-ADM2795EARDZ Arduino Shield with the widely available Arduino UNO to easily evaluate the ADM2795E 5 kV rms signal isolated RS-485 transceiver with Level 4 IEC EMC and 24 V supply fault protection.

The ADM2795E is an RS-485 transceiver that integrates IEC 61000-4-5 Level 4 surge protection, allowing up to  $\pm 4$  kV protection on the RS-485 bus pins (A and B). The device has IEC 61000-4-4 Level 4 EFT protection up to  $\pm 2$  kV and IEC 61000-4-2 Level 4 ESD protection on the bus pins, allowing this device to withstand up to  $\pm 15$  kV on the transceiver interface pins without latching up.



This Wiki guide provides hardware references and Arduino software for full integration of the EVAL-ADM2795EARDZ in a demonstration platform.

## Connectors and Jumper Configurations

The EVAL-ADM2795EARDZ features an RS-485 bus cable connector, an Arduino connector block, and some jumper blocks. The jumper blocks can be used to connect to external devices such as ultrasonic sensors (e.g. Ultrasonic HC-SR04 Distance Measuring Transducer), or joysticks (Arduino Compatible Analogue Joystick Controller). For the demonstration code and setup described in this Wiki guide only the Arduino connector block and RS-485 connector are used. The Joystick and Ultrasonic sensor jumper blocks are not supported with example software in this Wiki guide, however their general function is outlined below.



### Joystick

When the joystick mode is selected and the LED D4 is connected it will be turned off.

#### Configuration

#### Function



This connects 5V to pin 18 (D3) of the Arduino Uno and powers pins D0 to D7.

### Configuration

### Function



This connects pins 9 (A0) and 11 (A2) of the Arduino Uno



This connects pin 10 (A1) to GND of the Arduino Uno

### Ultrasound

An Ultrasonic HC-SR04 sensor can be connected to the EVAL-ADM2795EARDZ, and powered from an Arduino UNO.

### Configuration

### Function



This connects 5V to the pin 21 (D6) of the Arduino Uno and powers the D0 to D7 pins.



This connects pins 19 (D4) and 20 (D5) of the Arduino Uno.  
D4 is a LED that is used to switch between the ultrasonic and joystick functions. If the LED is on then the ultrasonic mode is enabled and if the LED is off then the joystick mode is enabled



This connects pin 22 (D7) to GND of the Arduino Uno.  
D7 is a button that toggles between turning on and off the LED at D4 that is used to toggle the two modes

### Terminal Block

### Configuration

### Function



This connects the ADM2795E RS-485 transceiver to the RS-485 differential bus cable. The 3-way terminal block provides A, B, and Ground wire connection points.

---

## Isolated Motor Control System using Arduino Form Factor Rapid Development Platforms

\\In this set-up the stimulus from an ultrasonic sensor at one end of the RS-485 bus controls a motor and gearing or fan assembly at the far end of the bus. The EVAL-ADICUP-360 Arduino form factor compatible ARM Cortex-M3 Development Platform accepts inputs from a standard ultrasonic sensor. The EVAL-ADICUP-360 outputs are used to control the EVAL-ADM2795EARDZ logic signals. The first EVAL-ADM2795EARDZ then transmits to a second EVAL-ADM2795EARDZ node over 10 meters of RS-485 Category 5e cable. On the far end of the bus, the second receiving EVAL-ADM2795EARDZ, EVAL-ADICUP-360, and Arduino Motor control shield and provide output to a standard industrial motor. Sample Arduino code for the transmitting and receiving RS-485 nodes is located at the end of this Wiki guide.

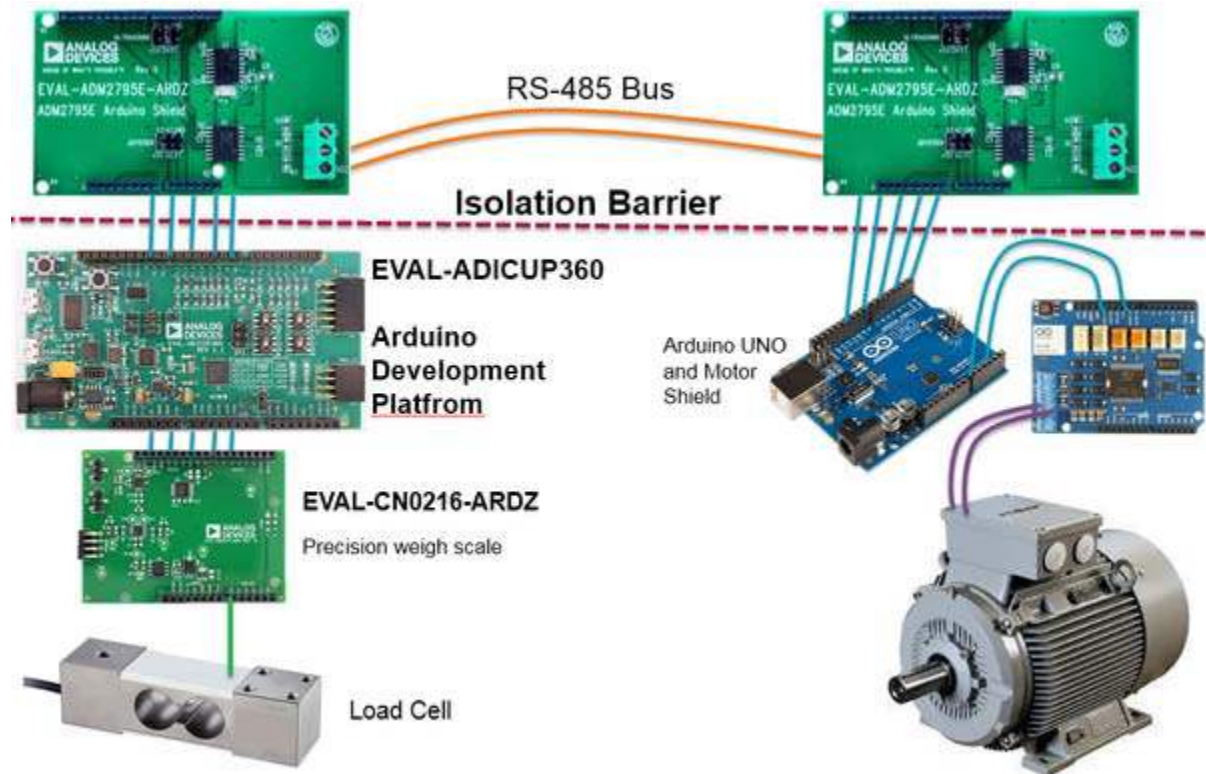



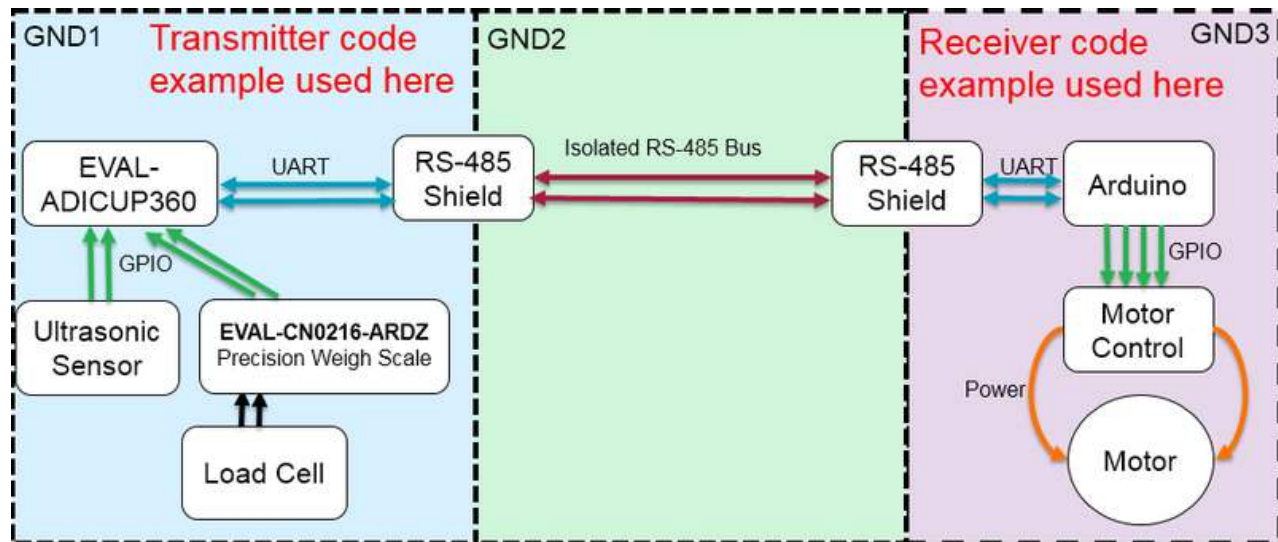

## Schematic, Bill of Materials, Gerber Files and Layout Files

- Schematic
- PCB Layout and Mounting Diagram
- Bill of Materials

## Change Log

- Initial Revision
- Added an example of how to use the ADM2795E with some code, pictures and a brief explanation

## Resources

\*Standard Evaluation Board User Guide: <http://www.analog.com/media/en/technical-documentation/user-guides/EVAL-ADM2795EEBZ-UG-997.pdf>

\*Data Sheet: <http://www.analog.com/media/en/technical-documentation/data-sheets/ADM2795E.pdf>

\*Application Note: <http://www.analog.com/media/en/technical-documentation/application-notes/AN-1398.pdf>

## Software

- Arduino Uno Example Code
  - Reciever and Transmitter sample code