

THIS DRAWING IS UNPUBLISHED. RELEASED FOR PUBLICATION
 © COPYRIGHT 2011 BY TYCO ELECTRONICS CORPORATION. ALL RIGHTS RESERVED.

LOC	DIST	REVISIONS					
DW		P	LTR	DESCRIPTION	DATE	DWN	APVD
		C		ECR-12-012115	26OCT'12	EL	WK

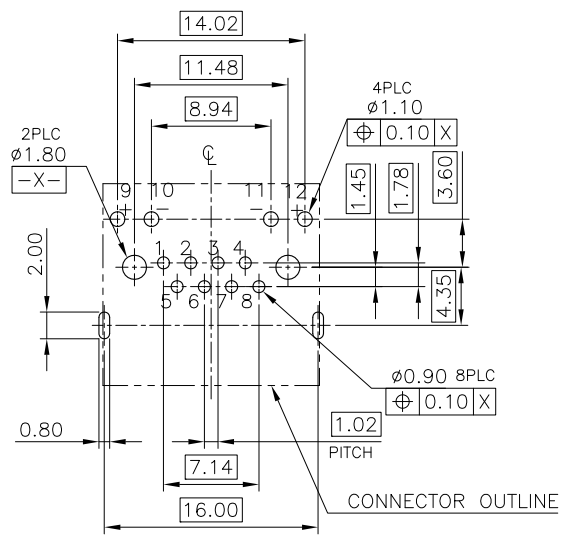
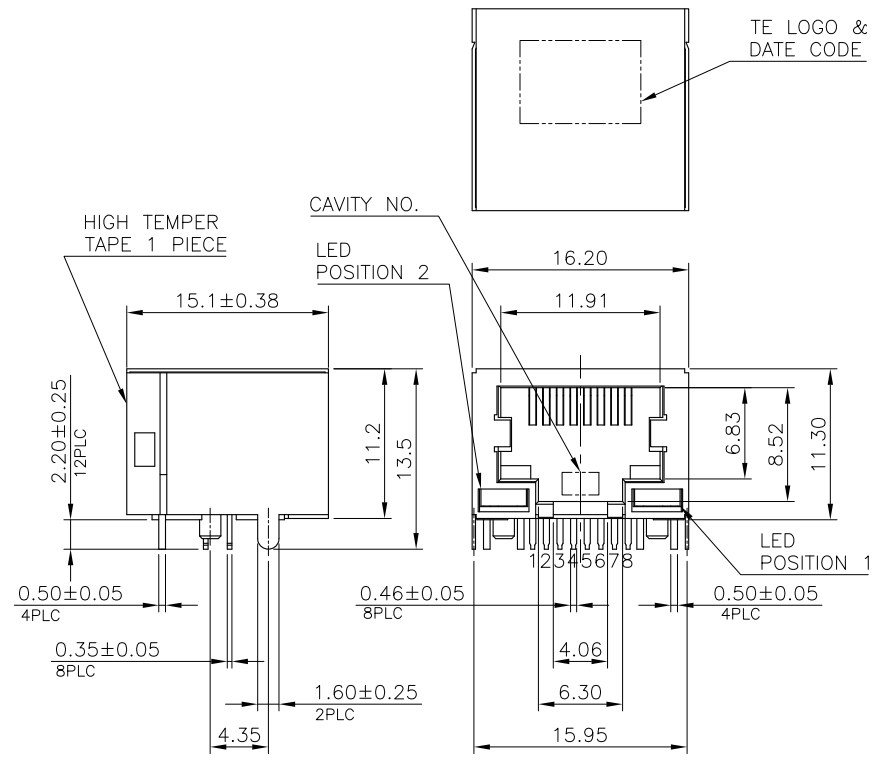

RECOMMENDED PCB LAYOUT
 RECOMMENDED PCB THICKNESS: 1.6mm
 TOLERANCE: ±0.05 (TOP VIEW)

NOTE:

- MATERIAL:
 HOUSING: PA9T WITH 30% GF, UL94 V-0, BLACK COLOR.
 CONTACTS: PHOSPHOR BRONZE.
 SHELL: BRASS.
- FINISH:
 CONTACTS: GOLD PLATED (SEE TABLE) ON CONTACT AREA, GOLD FLASH ON SOLDER TAIL, WITH ENTIRE CONTACT UNDERPLATED 1.27µm [50µ"] MIN. NICKEL.
 SHELL: 0.51µm [20µ"] MIN. NICKEL PLATED.
- REFLOW SOLDER CAPABLE TO 260°C PER TEC-109-201, CONDITION B.

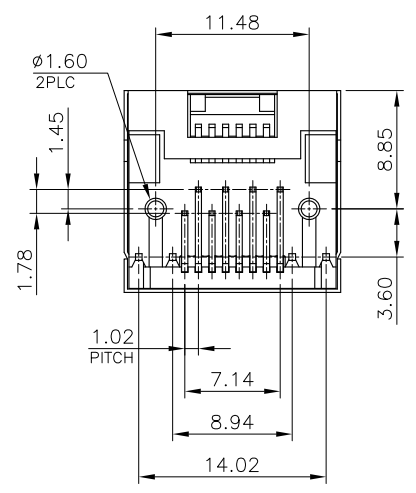
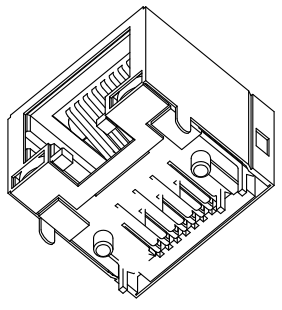
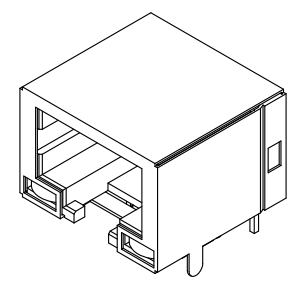

OBSOLETE	GREEN	YELLOW	1.27µm [50µ"]	1775452-4
			0.76µm [30µ"]	-1775452-3-
			0.38µm [15µ"]	-1775452-2-
			0.15µm [6µ"]	-1775452-1-
POSITION 2		POSITION 1	MIN. GOLD THICKNESS	PART NUMBER
INDICATOR COLOR				

THIS DRAWING IS A CONTROLLED DOCUMENT.		DWN	O. HU	30OCT2006	TE Connectivity
DIMENSIONS: mm		CHK	S. HOU	30OCT2006	
TOLERANCES UNLESS OTHERWISE SPECIFIED:		APVD	W.J. KE	30OCT2006	
0 PLC ± - 1 PLC ± 0.3 2 PLC ± 0.2 3 PLC ± 0.15 4 PLC ± - ± 3°		PRODUCT SPEC	108-57535		
MATERIAL	SEE NOTE	APPLICATION SPEC	NAME		MODULAR JACK, RJ45, REVERSE VERSION
FINISH	SEE NOTE	WEIGHT	4.5 GRAMS	SIZE	A3
		CUSTOMER DRAWING	CAGE CODE	00779	DRAWING NO
		SCALE	C=1775452		RESTRICTED TO
		SHEET	1 OF 2		REV
					C

THIS DRAWING IS UNPUBLISHED. RELEASED FOR PUBLICATION
 © COPYRIGHT 2011 BY TYCO ELECTRONICS CORPORATION. ALL RIGHTS RESERVED.

LOC DW	DIST	REVISIONS			
P	LTR	DESCRIPTION	DATE	DWN	APVD
		SEE SHEET 1.			

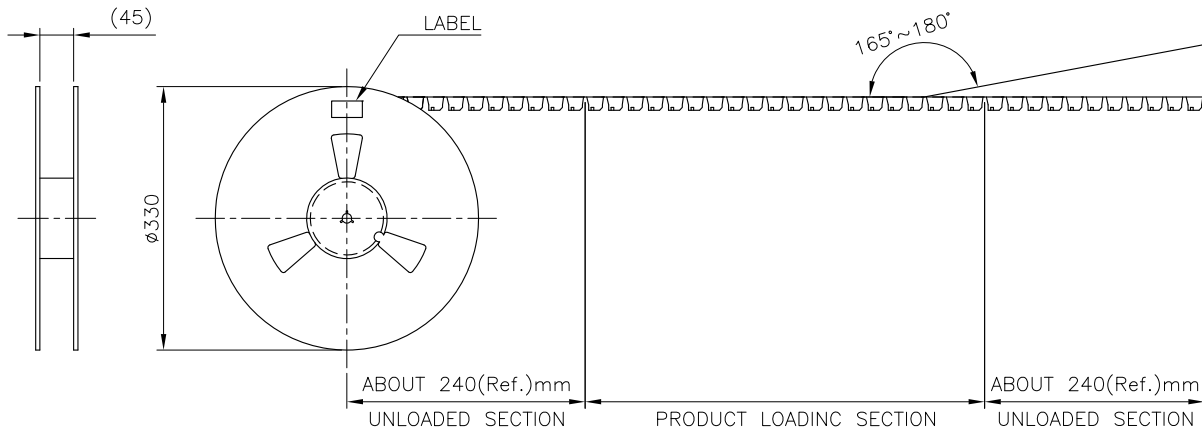

- NOTE:
- PACKAGING MATERIAL:
 - COVER TAPE: COMPOSITE OF POLYETHYLENE TEREPHTHALATE (PET)
 - CARRIER: POLYSTYRENE (PS)
 - CARRIER REEL: POLYSTYRENE
 - BAG: PET
 - BOX: CORRUGATED FIBER.
 - EACH BAG SHALL BE INCLUDED:
 - *DESICCANT
 - PEELING STRENGTH: 0.1~1.3N(1~130 GRAMS) FOR 12~56mm WIDE CARRIER TAPES
 - PEELING SPEED: 300mm/MINUTES.

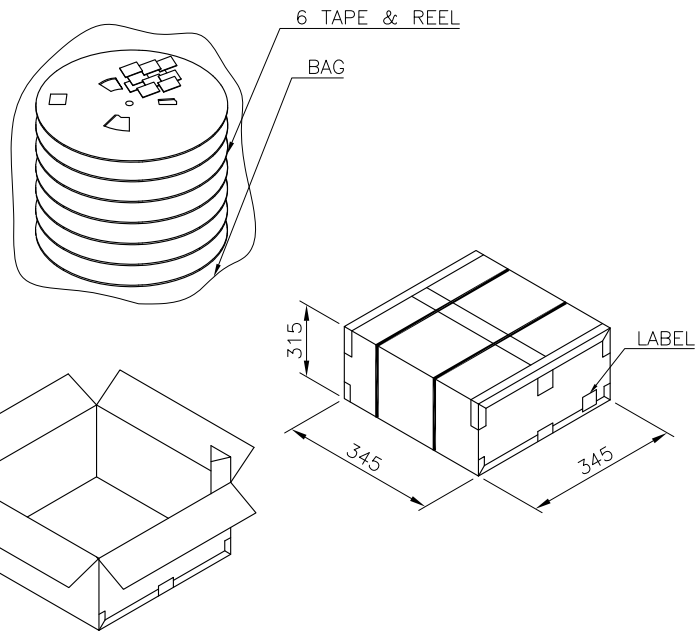
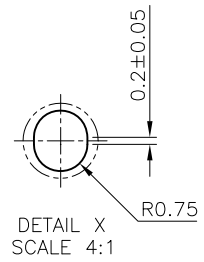
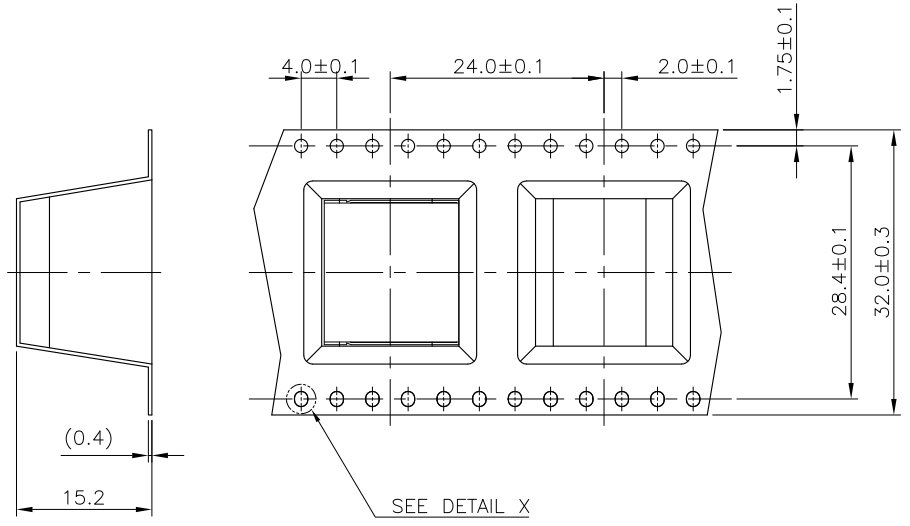

8.30KG	4.57KG	180	6	1080
GROSS WEIGHT	NET WEIGHT	PCS/ REEL	REEL/ BOX	PCS/ BOX

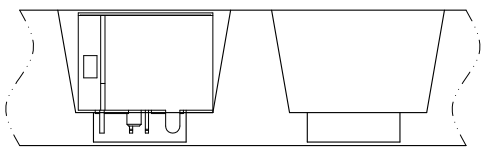

THIS DRAWING IS A CONTROLLED DOCUMENT.		DWN	TE Connectivity		
DIMENSIONS: mm		CHK	NAME		
TOLERANCES UNLESS OTHERWISE SPECIFIED:		APVD	MODULAR JACK, RJ45, REVERSE VERSION		
0 PLC ±		PRODUCT SPEC	SIZE	CAGE CODE	DRAWING NO
1 PLC ±0.3		APPLICATION SPEC	A3	00779	C=1775452
2 PLC ±0.2		WEIGHT	RESTRICTED TO		
3 PLC ±0.15		CUSTOMER DRAWING	SCALE	SHEET	REV
4 PLC ±				2 of 2	C
ANGLES ± 3'					
FINISH					