

**1-Mbit (128K × 8/64K × 16) nvSRAM with Real Time Clock**

**Features**

- 1-Mbit nonvolatile static random access memory (nvSRAM)
  - 25 ns and 45 ns access times
  - Internally organized as 128K × 8 (CY14B101KA) or 64K × 16 (CY14B101MA)
  - Hands off automatic STORE on power-down with only a small capacitor
  - STORE to QuantumTrap nonvolatile elements is initiated by software, hardware, or AutoStore on power-down
  - RECALL to SRAM initiated on power-up or by software
- High reliability
  - Infinite Read, Write, and RECALL cycles
  - 1 million STORE cycles to QuantumTrap
  - 20 year data retention
- Real time clock (RTC)
  - Full featured real time clock
  - Watchdog timer
  - Clock alarm with programmable interrupts
  - Capacitor or battery backup for RTC
  - Backup current of 0.35 μA (Typ)

- Industry standard configurations
  - Single 3 V +20%, -10% operation
  - Industrial temperature
- Packages
  - 44-/54-pin thin small outline package (TSOP) Type II
  - 48-pin shrink small outline package (SSOP)
- Pb-free and restriction of hazardous substances (RoHS) compliant

**Functional Description**

The Cypress CY14B101KA/CY14B101MA combines a 1-Mbit nvSRAM with a full featured real time clock in a monolithic integrated circuit. The embedded nonvolatile elements incorporate QuantumTrap technology producing the world's most reliable nonvolatile memory. The SRAM is read and written an infinite number of times, while independent nonvolatile data resides in the nonvolatile elements.

The real time clock function provides an accurate clock with leap year tracking and a programmable, high accuracy oscillator. The alarm function is programmable for periodic minutes, hours, days, or months alarms. There is also a programmable watchdog timer for process control.

For a complete list of related documentation, click [here](#).

**Logic Block Diagram<sup>[1, 2, 3]</sup>**

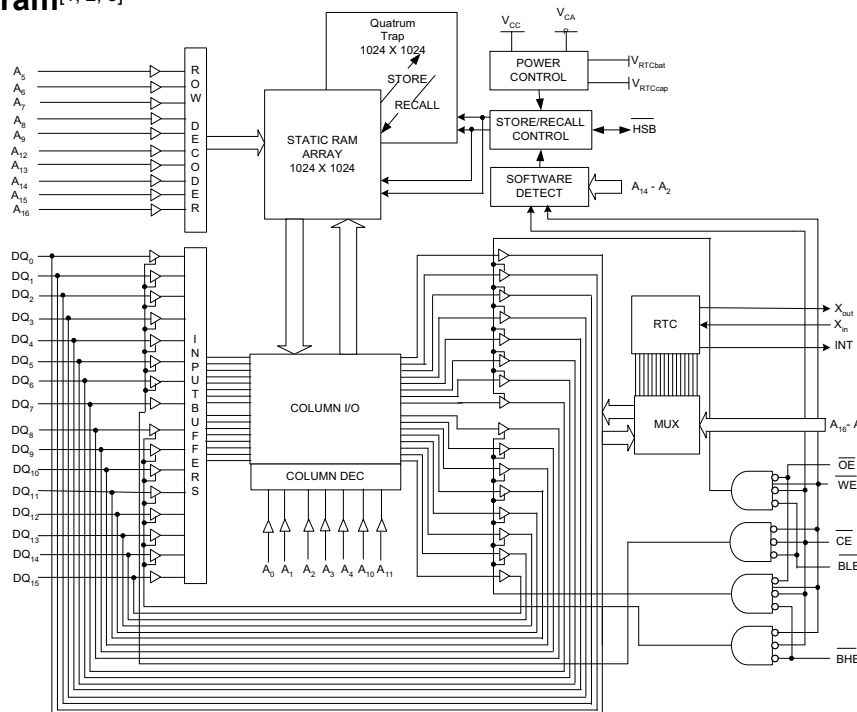

**Notes**

1. Address A<sub>0</sub>–A<sub>16</sub> for × 8 configuration and Address A<sub>0</sub>–A<sub>15</sub> for × 16 configuration.
2. Data DQ<sub>0</sub>–DQ<sub>7</sub> for × 8 configuration and Data DQ<sub>0</sub>–DQ<sub>15</sub> for × 16 configuration.
3. BHE and BLE are applicable for × 16 configuration only.

## Contents

<b>Pinouts</b> .....	<b>3</b>	<b>Data Retention and Endurance</b> .....	<b>19</b>
<b>Pin Definitions</b> .....	<b>4</b>	<b>Capacitance</b> .....	<b>19</b>
<b>Device Operation</b> .....	<b>5</b>	<b>Thermal Resistance</b> .....	<b>19</b>
SRAM Read .....	5	<b>AC Test Loads</b> .....	<b>20</b>
SRAM Write .....	5	<b>AC Test Conditions</b> .....	<b>20</b>
AutoStore Operation .....	5	<b>RTC Characteristics</b> .....	<b>20</b>
Hardware STORE (HSB) Operation .....	5	<b>AC Switching Characteristics</b> .....	<b>21</b>
Hardware RECALL (Power-Up) .....	6	SRAM Read Cycle .....	21
Software STORE .....	6	SRAM Write Cycle .....	21
Software RECALL .....	6	<b>Switching Waveforms</b> .....	<b>22</b>
Preventing AutoStore .....	8	<b>AutoStore/Power-Up RECALL</b> .....	<b>25</b>
Data Protection .....	8	<b>Switching Waveforms</b> .....	<b>25</b>
<b>Real Time Clock Operation</b> .....	<b>8</b>	<b>Software Controlled STORE/RECALL Cycle</b> .....	<b>26</b>
nvTIME Operation .....	8	<b>Switching Waveforms</b> .....	<b>26</b>
Clock Operations .....	8	<b>Hardware STORE Cycle</b> .....	<b>27</b>
Reading the Clock .....	8	<b>Switching Waveforms</b> .....	<b>27</b>
Setting the Clock .....	8	<b>Truth Table for SRAM Operations</b> .....	<b>28</b>
Backup Power .....	8	<b>Truth Table for SRAM Operations</b> .....	<b>28</b>
Stopping and Starting the Oscillator .....	9	<b>HSB must remain HIGH for SRAM operations.</b> .....	<b>28</b>
Calibrating the Clock .....	9	<b>Ordering Information</b> .....	<b>29</b>
Alarm .....	9	<b>Package Diagrams</b> .....	<b>30</b>
Watchdog Timer .....	10	<b>Acronyms</b> .....	<b>33</b>
Power Monitor .....	10	<b>Document Conventions</b> .....	<b>33</b>
Interrupts .....	10	Units of Measure .....	33
Flags Register .....	11	<b>Document History Page</b> .....	<b>34</b>
RTC External Components .....	12	<b>Sales, Solutions, and Legal Information</b> .....	<b>37</b>
<b>PCB Design Considerations for RTC</b> .....	<b>13</b>	Worldwide Sales and Design Support .....	37
Layout requirements .....	13	Products .....	37
<b>Maximum Ratings</b> .....	<b>18</b>	PSoC® Solutions .....	37
<b>Operating Range</b> .....	<b>18</b>	Cypress Developer Community .....	37
<b>DC Electrical Characteristics</b> .....	<b>18</b>	Technical Support .....	37

**Pinouts**

**Figure 1. Pin Diagram – 44-pin, 54-pin TSOP II, and 48-pin SSOP**

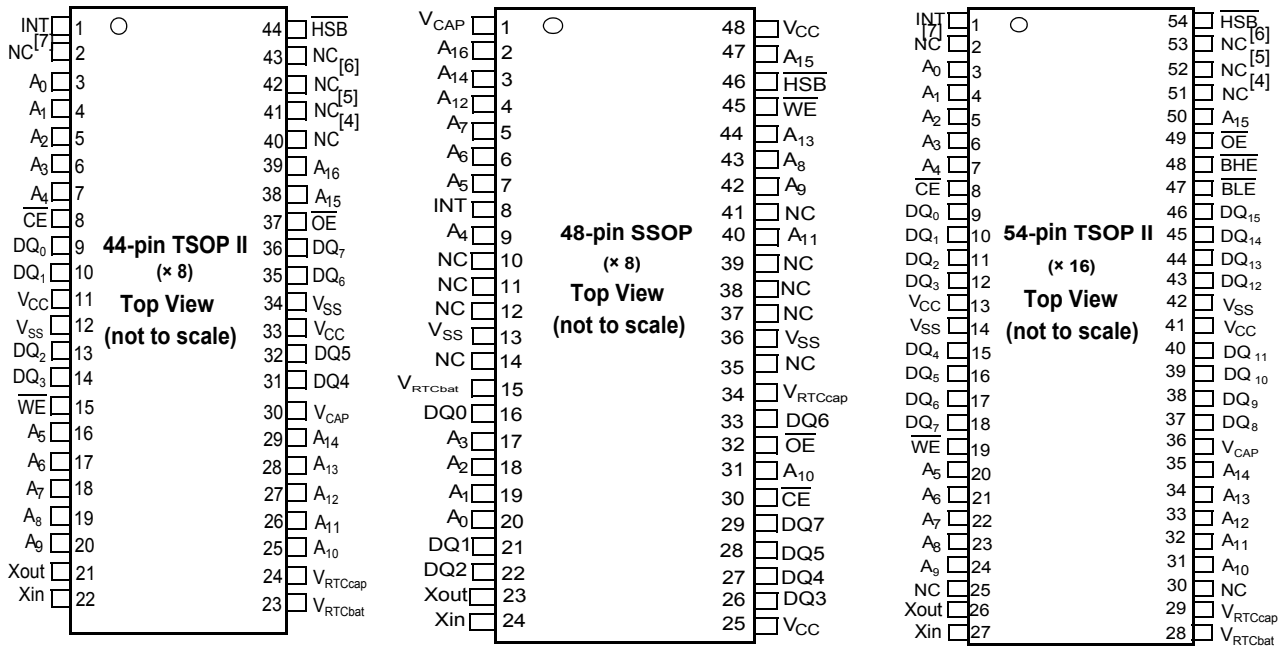

**Notes**

4. Address expansion for 2-Mbit. NC pin not connected to die.
5. Address expansion for 4-Mbit. NC pin not connected to die.
6. Address expansion for 8-Mbit. NC pin not connected to die.
7. Address expansion for 16-Mbit. NC pin not connected to die.

## Pin Definitions

Pin Name	I/O Type	Description
A <sub>0</sub> –A <sub>16</sub>	Input	Address inputs. Used to select one of the 131,072 Bytes of the nvSRAM for × 8 configuration.
A <sub>0</sub> –A <sub>15</sub>		Address inputs. Used to select one of the 65,536 Words of the nvSRAM for × 16 configuration.
DQ <sub>0</sub> –DQ <sub>7</sub>	Input/Output	Bidirectional data I/O Lines for × 8 configuration. Used as input or output lines depending on operation.
DQ <sub>0</sub> –DQ <sub>15</sub>		Bidirectional data I/O Lines for × 16 configuration. Used as input or output lines depending on operation.
NC	No connect	No connects. This pin is not connected to the die.
WE	Input	Write Enable input, Active LOW. When the chip is enabled and $\overline{WE}$ is LOW, data on the I/O pins is written to the specific address location.
CE	Input	Chip Enable input, Active LOW. When LOW, selects the chip. When HIGH, deselects the chip.
OE	Input	Output Enable, Active LOW. The active LOW $\overline{OE}$ input enables the data output buffers during read cycles. Deasserting $\overline{OE}$ HIGH causes the I/O pins to tristate.
BHE	Input	Byte High Enable, Active LOW. Controls DQ <sub>15</sub> –DQ <sub>8</sub> .
BLE	Input	Byte Low Enable, Active LOW. Controls DQ <sub>7</sub> –DQ <sub>0</sub> .
X <sub>out</sub> <sup>[8]</sup>	Output	Crystal connection. Drives crystal on start up.
X <sub>in</sub> <sup>[8]</sup>	Input	Crystal connection. For 32.768 kHz crystal.
V <sub>RTCcap</sub> <sup>[8]</sup>	Power supply	Capacitor supplied backup RTC supply voltage. Left unconnected if V <sub>RTCbat</sub> is used.
V <sub>RTCbat</sub> <sup>[8]</sup>	Power supply	Battery supplied backup RTC supply voltage. Left unconnected if V <sub>RTCcap</sub> is used.
INT <sup>[8]</sup>	Output	Interrupt output. Programmable to respond to the clock alarm, the watchdog timer, and the power monitor. Also programmable to either active HIGH (push or pull) or LOW (open drain).
V <sub>SS</sub>	Ground	Ground for the device. Must be connected to the ground of the system.
V <sub>CC</sub>	Power supply	Power supply inputs to the device. 3.0 V +20%, –10%
HSB	Input/Output	Hardware STORE Busy (HSB) Output: Indicates busy status of nvSRAM when LOW. After each Hardware and Software STORE operation, HSB is driven HIGH for a short time (t <sub>HHD</sub> ) with standard output high current and then a weak internal pull-up resistor keeps this pin HIGH (external pull-up resistor connection optional). Input: Hardware STORE implemented by pulling this pin LOW externally.
V <sub>CAP</sub>	Power supply	AutoStore capacitor. Supplies power to the nvSRAM during power loss to store data from SRAM to nonvolatile elements.

**Note**

8. Left unconnected if RTC feature is not used.

## Device Operation

The CY14B101KA/CY14B101MA nvSRAM is made up of two functional components paired in the same physical cell. These are a SRAM memory cell and a nonvolatile QuantumTrap cell. The SRAM memory cell operates as a standard fast static RAM. Data in the SRAM is transferred to the nonvolatile cell (the STORE operation), or from the nonvolatile cell to the SRAM (the RECALL operation). Using this unique architecture, all cells are stored and recalled in parallel. During the STORE and RECALL operations SRAM read and write operations are inhibited. The CY14B101KA/CY14B101MA supports infinite reads and writes similar to a typical SRAM. In addition, it provides infinite RECALL operations from the nonvolatile cells and up to 1 million STORE operations. See [Truth Table for SRAM Operations on page 28](#) for a complete description of read and write modes.

### SRAM Read

The CY14B101KA/CY14B101MA performs a read cycle whenever  $\overline{CE}$  and  $\overline{OE}$  are LOW, and  $\overline{WE}$  and  $\overline{HSB}$  are HIGH. The address specified on pins  $A_{0-16}$  or  $A_{0-15}$  determines which of the 131,072 data bytes or 65,536 words of 16 bits each are accessed. Byte enables ( $\overline{BHE}$ ,  $\overline{BLE}$ ) determine which bytes are enabled to the output, in the case of 16-bit words. When the read is initiated by an address transition, the outputs are valid after a delay of  $t_{AA}$  (read cycle #1). If the read is initiated by  $\overline{CE}$  or  $\overline{OE}$ , the outputs are valid at  $t_{ACE}$  or at  $t_{DOE}$ , whichever is later (read cycle #2). The data output repeatedly responds to address changes within the  $t_{AA}$  access time without the need for transitions on any control input pins. This remains valid until another address change or until  $\overline{CE}$  or  $\overline{OE}$  is brought HIGH, or  $\overline{WE}$  or  $\overline{HSB}$  is brought LOW.

### SRAM Write

A write cycle is performed when  $\overline{CE}$  and  $\overline{WE}$  are LOW and  $\overline{HSB}$  is HIGH. The address inputs must be stable before entering the write cycle and must remain stable until  $\overline{CE}$  or  $\overline{WE}$  goes HIGH at the end of the cycle. The data on the common I/O pins  $IO_{0-7}$  are written into the memory if it is valid  $t_{SD}$  before the end of a  $\overline{WE}$ -controlled write, or before the end of a  $\overline{CE}$ -controlled write. The Byte Enable inputs ( $\overline{BHE}$ ,  $\overline{BLE}$ ) determine which bytes are written, in the case of 16-bit words. It is recommended that  $\overline{OE}$  be kept HIGH during the entire write cycle to avoid data bus contention on common I/O lines. If  $\overline{OE}$  is left LOW, internal circuitry turns off the output buffers  $t_{HZWE}$  after  $\overline{WE}$  goes LOW.

### AutoStore Operation

The CY14B101KA/CY14B101MA stores data to the nvSRAM using one of three storage operations. These three operations are: Hardware STORE, activated by the  $\overline{HSB}$ ; Software STORE, activated by an address sequence; AutoStore, on device power-down. The AutoStore operation is a unique feature of QuantumTrap technology and is enabled by default on the CY14B101KA/CY14B101MA.

During a normal operation, the device draws current from  $V_{CC}$  to charge a capacitor connected to the  $V_{CAP}$  pin. This stored charge is used by the chip to perform a single STORE operation. If the voltage on the  $V_{CC}$  pin drops below  $V_{SWITCH}$ , the part

automatically disconnects the  $V_{CAP}$  pin from  $V_{CC}$ . A STORE operation is initiated with power provided by the  $V_{CAP}$  capacitor.

**Note** If the capacitor is not connected to  $V_{CAP}$  pin, AutoStore must be disabled using the soft sequence specified in [Preventing AutoStore on page 8](#). In case AutoStore is enabled without a capacitor on  $V_{CAP}$  pin, the device attempts an AutoStore operation without sufficient charge to complete the Store. This corrupts the data stored in nvSRAM.

**Figure 2. AutoStore Mode**

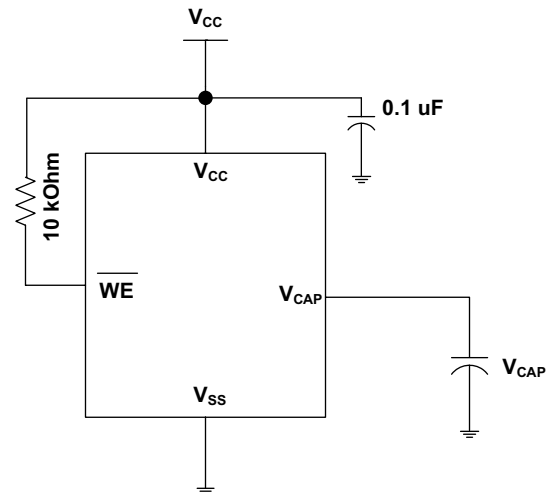

Figure 2 shows the proper connection of the storage capacitor ( $V_{CAP}$ ) for automatic STORE operation. See [DC Electrical Characteristics on page 18](#) for the size of the  $V_{CAP}$ . The voltage on the  $V_{CAP}$  pin is driven to  $V_{CC}$  by a regulator on the chip. A pull-up should be placed on  $\overline{WE}$  to hold it inactive during power-up. This pull-up is only effective if the  $\overline{WE}$  signal is tristate during power-up. Many MPUs tristate their controls on power-up. This should be verified when using the pull-up. When the nvSRAM comes out of power-on-RECALL, the MPU must be active or the  $\overline{WE}$  held inactive until the MPU comes out of reset.

To reduce unnecessary nonvolatile stores, AutoStore and Hardware STORE operations are ignored unless at least one write operation has taken place since the most recent STORE or RECALL cycle. Software initiated STORE cycles are performed regardless of whether a write operation has taken place.

### Hardware STORE ( $\overline{HSB}$ ) Operation

The CY14B101KA/CY14B101MA provides the  $\overline{HSB}$  pin to control and acknowledge the STORE operations. The  $\overline{HSB}$  pin is used to request a Hardware STORE cycle. When the  $\overline{HSB}$  pin is driven LOW, the CY14B101KA/CY14B101MA conditionally initiates a STORE operation after  $t_{DELAY}$ . An actual STORE cycle begins only if a write to the SRAM has taken place since the last STORE or RECALL cycle. The  $\overline{HSB}$  pin also acts as an open drain driver (internal 100 k $\Omega$  weak pull-up resistor) that is internally driven LOW to indicate a busy condition when the STORE (initiated by any means) is in progress.

**Note** After each Hardware and Software STORE operation  $\overline{HSB}$  is driven HIGH for a short time ( $t_{HHHD}$ ) with standard output high current and then remains HIGH by internal 100 k $\Omega$  pull-up resistor.

SRAM write operations that are in progress when  $\overline{\text{HSB}}$  is driven LOW by any means are given time ( $t_{\text{DELAY}}$ ) to complete before the STORE operation is initiated. However, any SRAM write cycles requested after  $\overline{\text{HSB}}$  goes LOW are inhibited until  $\overline{\text{HSB}}$  returns HIGH. In case the write latch is not set,  $\overline{\text{HSB}}$  is not driven LOW by the CY14B101KA/CY14B101MA. But any SRAM read and write cycles are inhibited until  $\overline{\text{HSB}}$  is returned HIGH by MPU or other external source.

During any STORE operation, regardless of how it is initiated, the CY14B101KA/CY14B101MA continues to drive the  $\overline{\text{HSB}}$  pin LOW, releasing it only when the STORE is complete. Upon completion of the STORE operation, the nvSRAM memory access is inhibited for  $t_{\text{LZHSB}}$  time after  $\overline{\text{HSB}}$  pin returns HIGH. Leave the  $\overline{\text{HSB}}$  unconnected if it is not used.

### Hardware RECALL (Power-Up)

During power-up or after any low power condition ( $V_{\text{CC}} < V_{\text{SWITCH}}$ ), an internal RECALL request is latched. When  $V_{\text{CC}}$  again exceeds the  $V_{\text{SWITCH}}$  on power-up, a RECALL cycle is automatically initiated and takes  $t_{\text{HRECALL}}$  to complete. During this time, the  $\overline{\text{HSB}}$  pin is driven LOW by the  $\overline{\text{HSB}}$  driver and all reads and writes to nvSRAM are inhibited.

### Software STORE

Data is transferred from the SRAM to the nonvolatile memory by a software address sequence. The CY14B101KA/CY14B101MA Software STORE cycle is initiated by executing sequential  $\overline{\text{CE}}$  or  $\overline{\text{OE}}$  controlled read cycles from six specific address locations in exact order. During the STORE cycle, an erase of the previous nonvolatile data is first performed, followed by a program of the nonvolatile elements. After a STORE cycle is initiated, further input and output are disabled until the cycle is completed.

Because a sequence of reads from specific addresses is used for STORE initiation, it is important that no other read or write accesses intervene in the sequence, or the sequence is aborted and no STORE or RECALL takes place.

To initiate the Software STORE cycle, the following read sequence must be performed:

1. Read address 0x4E38 Valid READ
2. Read address 0xB1C7 Valid READ
3. Read address 0x83E0 Valid READ
4. Read address 0x7C1F Valid READ
5. Read address 0x703F Valid READ
6. Read address 0x8FC0 Initiate STORE cycle

The software sequence may be clocked with  $\overline{\text{CE}}$  controlled reads or  $\overline{\text{OE}}$  controlled reads, with  $\overline{\text{WE}}$  kept HIGH for all the six READ sequences. After the sixth address in the sequence is entered, the STORE cycle commences and the chip is disabled.  $\overline{\text{HSB}}$  is driven LOW. After the  $t_{\text{STORE}}$  cycle time is fulfilled, the SRAM is activated again for the read and write operation.

### Software RECALL

Data is transferred from the nonvolatile memory to the SRAM by a software address sequence. A Software RECALL cycle is initiated with a sequence of read operations in a manner similar to the Software STORE initiation. To initiate the RECALL cycle, the following sequence of  $\overline{\text{CE}}$  or  $\overline{\text{OE}}$  controlled read operations must be performed:

1. Read address 0x4E38 Valid READ
2. Read address 0xB1C7 Valid READ
3. Read address 0x83E0 Valid READ
4. Read address 0x7C1F Valid READ
5. Read address 0x703F Valid READ
6. Read address 0x4C63 Initiate RECALL cycle

Internally, RECALL is a two step procedure. First, the SRAM data is cleared. Next, the nonvolatile information is transferred into the SRAM cells. After the  $t_{\text{RECALL}}$  cycle time, the SRAM is again ready for read and write operations. The RECALL operation does not alter the data in the nonvolatile elements.

**Table 1. Mode Selection**

CE	WE	OE	BHE, BLE <sup>[9]</sup>	A <sub>15</sub> -A <sub>0</sub> <sup>[10]</sup>	Mode	I/O	Power
H	X	X	X	X	Not selected	Output high Z	Standby
L	H	L	L	X	Read SRAM	Output data	Active
L	L	X	L	X	Write SRAM	Input data	Active
L	H	L	X	0x4E38 0xB1C7 0x83E0 0x7C1F 0x703F 0x8B45	Read SRAM Read SRAM Read SRAM Read SRAM Read SRAM AutoStore Disable	Output data Output data Output data Output data Output data Output data	Active <sup>[11]</sup>
L	H	L	X	0x4E38 0xB1C7 0x83E0 0x7C1F 0x703F 0x4B46	Read SRAM Read SRAM Read SRAM Read SRAM Read SRAM AutoStore Enable	Output data Output data Output data Output data Output data Output data	Active <sup>[11]</sup>
L	H	L	X	0x4E38 0xB1C7 0x83E0 0x7C1F 0x703F 0x8FC0	Read SRAM Read SRAM Read SRAM Read SRAM Read SRAM Nonvolatile STORE	Output data Output data Output data Output data Output data Output high Z	Active I <sub>CC2</sub> <sup>[11]</sup>
L	H	L	X	0x4E38 0xB1C7 0x83E0 0x7C1F 0x703F 0x4C63	Read SRAM Read SRAM Read SRAM Read SRAM Read SRAM Nonvolatile RECALL	Output data Output data Output data Output data Output data Output high Z	Active <sup>[11]</sup>

**Notes**

9. BHE and BLE are applicable for × 16 configuration only.

10. While there are 17 address lines on the CY14B101KA (16 address lines on the CY14B101MA), only the 13 address lines (A<sub>14</sub>-A<sub>2</sub>) are used to control software modes. The remaining address lines are don't care.

11. The six consecutive address locations must be in the order listed. WE must be HIGH during all six cycles to enable a nonvolatile cycle.

## Preventing AutoStore

The AutoStore function is disabled by initiating an AutoStore disable sequence. A sequence of read operations is performed in a manner similar to the Software STORE initiation. To initiate the AutoStore disable sequence, the following sequence of  $\overline{CE}$  or  $\overline{OE}$  controlled read operations must be performed:

1. Read address 0x4E38 Valid READ
2. Read address 0xB1C7 Valid READ
3. Read address 0x83E0 Valid READ
4. Read address 0x7C1F Valid READ
5. Read address 0x703F Valid READ
6. Read address 0x8B45 AutoStore Disable

The AutoStore is re-enabled by initiating an AutoStore enable sequence. A sequence of read operations is performed in a manner similar to the Software RECALL initiation.

To initiate the AutoStore enable sequence, the following sequence of  $\overline{CE}$  or  $\overline{OE}$  controlled read operations must be performed:

1. Read address 0x4E38 Valid READ
2. Read address 0xB1C7 Valid READ
3. Read address 0x83E0 Valid READ
4. Read address 0x7C1F Valid READ
5. Read address 0x703F Valid READ
6. Read address 0x4B46 AutoStore Enable

If the AutoStore function is disabled or re-enabled, a manual STORE operation (Hardware or Software) issued to save the AutoStore state through subsequent power-down cycles. The part comes from the factory with AutoStore enabled and 0x00 written in all cells.

## Data Protection

The CY14B101KA/CY14B101MA protects data from corruption during low voltage conditions by inhibiting all externally initiated STORE and write operations. The low voltage condition is detected when  $V_{CC}$  is less than  $V_{SWITCH}$ . If the CY14B101KA/CY14B101MA is in a write mode (both  $\overline{CE}$  and  $\overline{WE}$  are LOW) at power-up, after a RECALL or STORE, the write is inhibited until the SRAM is enabled after  $t_{LZHSB}$  (HSB to output active). This protects against inadvertent writes during power-up or brown out conditions.

## Real Time Clock Operation

### nvTIME Operation

The CY14B101KA/CY14B101MA offers internal registers that contain clock, alarm, watchdog, interrupt, and control functions. RTC registers use the last 16 address locations of the SRAM. Internal double buffering of the clock and timer information registers prevents accessing transitional internal clock data during a read or write operation. Double buffering also circumvents disrupting normal timing counts or the clock accuracy of the internal clock when accessing clock data. Clock and alarm registers store data in BCD format.

RTC functionality is described with respect to CY14B101KA in the following sections. The same description applies to CY14B101MA, except for the RTC register addresses. The RTC

register addresses for CY14B101KA range from 0x1FFF0 to 0x1FFFF, while those for CY14B101MA range from 0x0FFF0 to 0x0FFFF. See Table 3 on page 14 and Table 4 on page 15 for a detailed Register Map description.

## Clock Operations

The clock registers maintain time up to 9,999 years in one-second increments. The time can be set to any calendar time and the clock automatically keeps track of days of the week and month, leap years, and century transitions. There are eight registers dedicated to the clock functions, which are used to set time with a write cycle and to read time with a read cycle. These registers contain the time of day in BCD format. Bits defined as '0' are currently not used and are reserved for future use by Cypress.

## Reading the Clock

The double buffered RTC register structure reduces the chance of reading incorrect data from the clock. Internal updates to the CY14B101KA time keeping registers are stopped when the read bit 'R' (in the flags register at 0x1FFF0) is set to '1' before reading clock data to prevent reading of data in transition. Stopping the register updates does not affect clock accuracy.

When a read sequence of RTC device is initiated, the update of the user timekeeping registers stops and does not restart until a '0' is written to the read bit 'R' (in the flags register at 0x1FFF0). After the end of read sequence, all the RTC registers are simultaneously updated within 20 ms.

## Setting the Clock

A write access to the RTC device stops updates to the time keeping registers and enables the time to be set when the write bit 'W' (in the flags register at 0x1FFF0) is set to '1'. The correct day, date, and time is then written into the registers and must be in 24 hour BCD format. The time written is referred to as the "Base Time". This value is stored in nonvolatile registers and used in the calculation of the current time. When the write bit 'W' is cleared by writing '0' to it, the values of timekeeping registers are transferred to the actual clock counters after which the clock resumes normal operation.

If the time written to the timekeeping registers is not in the correct BCD format, each invalid nibble of the RTC registers continue counting to 0xF before rolling over to 0x0 after which RTC resumes normal operation.

**Note** After 'W' bit is set to '0', values written into the timekeeping, alarm, calibration, and interrupt registers are transferred to the RTC time keeping counters in  $t_{RTCD}$  time. These counter values must be saved to nonvolatile memory either by initiating a Software/Hardware STORE or AutoStore operation. While working in AutoStore disabled mode, perform a STORE operation after  $t_{RTCD}$  time while writing into the RTC registers for the modifications to be correctly recorded.

## Backup Power

The RTC in the CY14B101KA is intended for permanently powered operation. The  $V_{RTCcap}$  or  $V_{RTCbat}$  pin is connected depending on whether a capacitor or battery is chosen for the application. When the primary power,  $V_{CC}$ , fails and drops below  $V_{SWITCH}$  the device switches to the backup power supply.



The clock oscillator uses very little current, which maximizes the backup time available from the backup source. Regardless of the clock operation with the primary source removed, the data stored in the nvSRAM is secure, having been stored in the nonvolatile elements when power was lost.

During backup operation, the CY14B101KA consumes a 0.35  $\mu$ A (Typ) at room temperature. The user must choose capacitor or battery values according to the application.

**Note:** If a battery is applied to  $V_{RTCbat}$  pin prior to  $V_{CC}$ , the chip will draw high  $I_{BAK}$  current. This occurs even if the oscillator is disabled. In order to maximize battery life,  $V_{CC}$  must be applied before a battery is applied to  $V_{RTCbat}$  pin.

Backup time values based on maximum current specifications are shown in the following Table 2. Nominal backup times are approximately two times longer.

**Table 2. RTC Backup Time**

Capacitor Value	Backup Time
0.1 F	72 hours
0.47 F	14 days
1.0 F	30 days

Using a capacitor has the obvious advantage of recharging the backup source each time the system is powered up. If a battery is used, a 3 V lithium is recommended and the CY14B101KA sources current only from the battery when the primary power is removed. However, the battery is not recharged at any time by the CY14B101KA. The battery capacity must be chosen for total anticipated cumulative down time required over the life of the system.

### Stopping and Starting the Oscillator

The OSCEN bit in the calibration register at 0x1FFF8 controls the enable and disable of the oscillator. This bit is nonvolatile and is shipped to customers in the “enabled” (set to ‘0’) state. To preserve the battery life when the system is in storage, OSCEN must be set to ‘1’. This turns off the oscillator circuit, extending the battery life. If the OSCEN bit goes from disabled to enabled, it takes approximately one second (two seconds maximum) for the oscillator to start.

While system power is off, if the voltage on the backup supply ( $V_{RTCcap}$  or  $V_{RTCbat}$ ) falls below their respective minimum level, the oscillator may fail. The CY14B101KA has the ability to detect oscillator failure when system power is restored. This is recorded in the Oscillator Fail Flag (OSCF) of the flags register at the address 0x1FFF0. When the device is powered on ( $V_{CC}$  goes above  $V_{SWITCH}$ ) the OSCEN bit is checked for the ‘enabled’ status. If the OSCEN bit is enabled and the oscillator is not active within the first 5 ms, the OSCF bit is set to ‘1’. The system must check for this condition and then write ‘0’ to clear the flag.

Note that in addition to setting the OSCF flag bit, the time registers are reset to the ‘Base Time’, which is the value last written to the timekeeping registers. The control or calibration registers and the OSCEN bit are not affected by the ‘oscillator failed’ condition.

The value of OSCF must be reset to ‘0’ when the time registers are written for the first time. This initializes the state of this bit

which may have become set when the system was first powered on.

To reset OSCF, set the write bit ‘W’ (in the flags register at 0x1FFF0) to a ‘1’ to enable writes to the flags register. Write a ‘0’ to the OSCF bit and then reset the write bit to ‘0’ to disable writes.

### Calibrating the Clock

The RTC is driven by a quartz controlled crystal with a nominal frequency of 32.768 kHz. Clock accuracy depends on the quality of the crystal and calibration. The crystals available in market typically have an error of  $\pm 20$  ppm to  $\pm 35$  ppm. However, CY14B101KA employs a calibration circuit that improves the accuracy to  $\pm 1/-2$  ppm at 25 °C. This implies an error of +2.5 seconds to -5 seconds per month.

The calibration circuit adds or subtracts counts from the oscillator divider circuit to achieve this accuracy. The number of pulses that are suppressed (subtracted, negative calibration) or split (added, positive calibration) depends upon the value loaded into the five calibration bits found in Calibration register at 0x1FFF8. The calibration bits occupy the five lower order bits in the Calibration register. These bits are set to represent any value between ‘0’ and 31 in binary form. Bit D5 is a sign bit, where a ‘1’ indicates positive calibration and a ‘0’ indicates negative calibration. Adding counts speeds the clock up and subtracting counts slows the clock down. If a binary ‘1’ is loaded into the register, it corresponds to an adjustment of 4.068 or -2.034 ppm offset in oscillator error, depending on the sign.

Calibration occurs within a 64-minute cycle. The first 62 minutes in the cycle may, once every minute, have one second shortened by 128 or lengthened by 256 oscillator cycles. If a binary ‘1’ is loaded into the register, only the first two minutes of the 64-minute cycle are modified. If a binary 6 is loaded, the first 12 are affected, and so on. Therefore, each calibration step has the effect of adding 512 or subtracting 256 oscillator cycles for every 125,829,120 actual oscillator cycles, that is, 4.068 or -2.034 ppm of adjustment per calibration step in the Calibration register.

To determine the required calibration, the CAL bit in the flags register (0x1FFF0) must be set to ‘1’. This causes the INT pin to toggle at a nominal frequency of 512 Hz. Any deviation measured from the 512 Hz indicates the degree and direction of the required correction. For example, a reading of 512.01024 Hz indicates a +20 ppm error. Hence, a decimal value of -10 (001010b) must be loaded into the Calibration register to offset this error.

**Note** Setting or changing the Calibration register does not affect the test output frequency.

To set or clear CAL, set the write bit ‘W’ (in the flags register at 0x1FFF0) to ‘1’ to enable writes to the flags register. Write a value to CAL, and then reset the write bit to ‘0’ to disable writes.

### Alarm

The alarm function compares user programmed values of alarm time and date (stored in the registers 0x1FFF1-5) with the corresponding time of day and date values. When a match occurs, the alarm internal flag (AF) is set and an interrupt is generated on INT pin if Alarm Interrupt Enable (AIE) bit is set.

There are four alarm match fields – date, hours, minutes, and seconds. Each of these fields has a match bit that is used to

determine if the field is used in the alarm match logic. Setting the match bit to '0' indicates that the corresponding field is used in the match process. Depending on the match bits, the alarm occurs as specifically as once a month or as frequently as once every minute. Selecting none of the match bits (all 1s) indicates that no match is required and therefore, alarm is disabled. Selecting all match bits (all 0s) causes an exact time and date match.

There are two ways to detect an alarm event: by reading the AF flag or monitoring the INT pin. The AF flag in the flags register at 0x1FFF0 indicates that a date or time match has occurred. The AF bit is set to '1' when a match occurs. Reading the flags register clears the alarm flag bit (and all others). A hardware interrupt pin may also be used to detect an alarm event.

To set, clear or enable an alarm, set the 'W' bit (in flags register – 0x1FFF0) to '1' to enable writes to Alarm Registers. After writing the alarm value, clear the 'W' bit back to '0' for the changes to take effect.

**Note** CY14B101KA requires the alarm match bit for seconds (bit 'D7' in Alarm-Seconds register 0x1FFF2) to be set to '0' for proper operation of Alarm Flag and Interrupt.

### Watchdog Timer

The watchdog timer is a free running down counter that uses the 32 Hz clock (31.25 ms) derived from the crystal oscillator. The oscillator must be running for the watchdog to function. It begins counting down from the value loaded in the watchdog timer register.

The timer consists of a loadable register and a free running counter. On power-up, the watchdog time out value in register 0x1FFF7 is loaded into the counter load register. Counting begins on power-up and restarts from the loadable value any time the watchdog strobe (WDS) bit is set to '1'. The counter is compared to the terminal value of '0'. If the counter reaches this value, it causes an internal flag and an optional interrupt output. You can prevent the time out interrupt by setting WDS bit to '1' prior to the counter reaching '0'. This causes the counter to reload with the watchdog time out value and to be restarted. As long as the user sets the WDS bit prior to the counter reaching the terminal value, the interrupt and WDT flag never occur.

New time out values are written by setting the watchdog write bit to '0'. When the WDW is '0', new writes to the watchdog time out value bits D5–D0 are enabled to modify the time out value. When WDW is '1', writes to bits D5–D0 are ignored. The WDW function enables a user to set the WDS bit without concern that the watchdog timer value is modified. A logical diagram of the watchdog timer is shown in [Figure 3](#). Note that setting the watchdog time out value to '0' disables the watchdog function.

The output of the watchdog timer is the flag bit WDF that is set if the watchdog is allowed to time out. If the watchdog interrupt enable (WIE) bit in the interrupt register is set, a hardware interrupt on INT pin is also generated on watchdog timeout. The flag and the hardware interrupt are both cleared when the user reads the flags registers.

Figure 3. Watchdog Timer Block Diagram

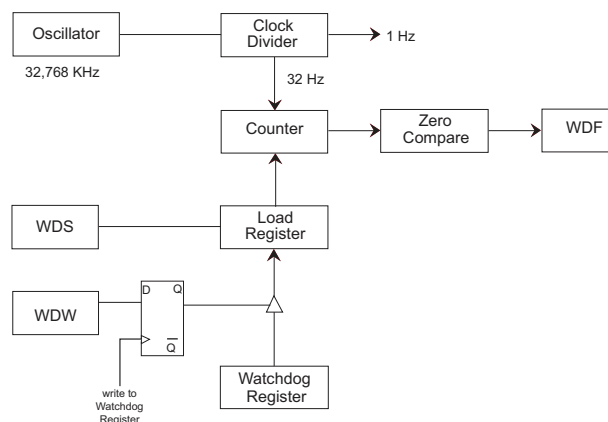

### Power Monitor

The CY14B101KA provides a power management scheme with power fail interrupt capability. It also controls the internal switch to backup power for the clock and protects the memory from low  $V_{CC}$  access. The power monitor is based on an internal bandgap reference circuit that compares the  $V_{CC}$  voltage to  $V_{SWITCH}$  threshold.

As described in the [AutoStore Operation on page 5](#), when  $V_{SWITCH}$  is reached as  $V_{CC}$  decays from power loss, a data STORE operation is initiated from SRAM to the nonvolatile elements, securing the last SRAM data state. Power is also switched from  $V_{CC}$  to the backup supply (battery or capacitor) to operate the RTC oscillator.

When operating from the backup source, read and write operations to nvSRAM are inhibited and the RTC functions are not available to the user. The RTC clock continues to operate in the background. The updated RTC time keeping registers data are available to the user after  $V_{CC}$  is restored to the device (see [AutoStore/Power-Up RECALL on page 25](#)).

### Interrupts

The CY14B101KA has flags register, interrupt register, and interrupt logic that can signal interrupt to the microcontroller. There are three potential sources for interrupt: watchdog timer, power monitor, and alarm timer. Each of these can be individually enabled to drive the INT pin by appropriate setting in the Interrupt register (0x1FFF6). In addition, each has an associated flag bit in the flags register (0x1FFF0) that the host processor uses to determine the cause of the interrupt. The INT pin driver has two bits that specify its behavior when an interrupt occurs.

An interrupt is raised only if both a flag is raised by one of the three sources and the respective interrupt enable bit in interrupts register is enabled (set to '1'). After an interrupt source is active, two programmable bits, H/L and P/L, determine the behavior of the output pin driver on INT pin. These two bits are located in the interrupt register and can be used to drive level or pulse mode output from the INT pin. In pulse mode, the pulse width is internally fixed at approximately 200 ms. This mode is intended to reset a host microcontroller. In the level mode, the pin goes to its active polarity until the flags register is read by the user. This

mode is used as an interrupt to a host microcontroller. The control bits are summarized in the following section.

Interrupts are only generated while working on normal power and are not triggered when system is running in backup power mode.

**Note** CY14B101KA generates valid interrupts only after the Power-up RECALL sequence is completed. All events on INT pin must be ignored for  $t_{HRECALL}$  duration after power-up.

### Interrupt Register

**Watchdog Interrupt Enable (WIE).** When set to '1', the watchdog timer drives the INT pin and an internal flag when a watchdog time out occurs. When WIE is set to '0', the watchdog timer only affects the WDF flag in Flags register .

**Alarm Interrupt Enable (AIE).** When set to '1', the alarm match drives the INT pin and an internal flag. When AIE is set to '0', the alarm match only affects the AF flag in Flags register .

**Power Fail Interrupt Enable (PFE).** When set to '1', the power fail monitor drives the pin and an internal flag. When PFE is set to '0', the power fail monitor only affects the PF flag in flags register.

**High/Low (H/L).** When set to a '1', the INT pin is active HIGH and the driver mode is push pull. The INT pin drives HIGH only when  $V_{CC}$  is greater than  $V_{SWITCH}$ . When set to a '0', the INT pin is active LOW and the drive mode is open drain. The INT pin

must be pulled up to  $V_{CC}$  by a 10 k resistor while using the interrupt in active LOW mode.

**Pulse/Level (P/L).** When set to a '1' and an interrupt occurs, the INT pin is driven for approximately 200 ms. When P/L is set to a '0', the INT pin is driven HIGH or LOW (determined by H/L) until the flags register is read.

When an enabled interrupt source activates the INT pin, an external host reads the flags registers to determine the cause. All flags are cleared when the register is read. If the INT pin is programmed for level mode, then the condition clears and the INT pin returns to its inactive state. If the pin is programmed for pulse mode, then reading the flag also clears the flag and the pin. The pulse does not complete its specified duration if the flags register is read. If the INT pin is used as a host reset, then the flags register is not read during a reset.

### Flags Register

The flags register has three flag bits: WDF, AF, and PF, which can be used to generate an interrupt. These flags are set by the watchdog timeout, alarm match, or power fail monitor respectively. The processor can either poll this register or enable interrupts to be informed when a flag is set. These flags are automatically reset when the register is read. The flags register is automatically loaded with the value 0x00 on power-up (except for the OSCF bit; see [Stopping and Starting the Oscillator on page 9](#)).

**Figure 4. Interrupt Block Diagram**

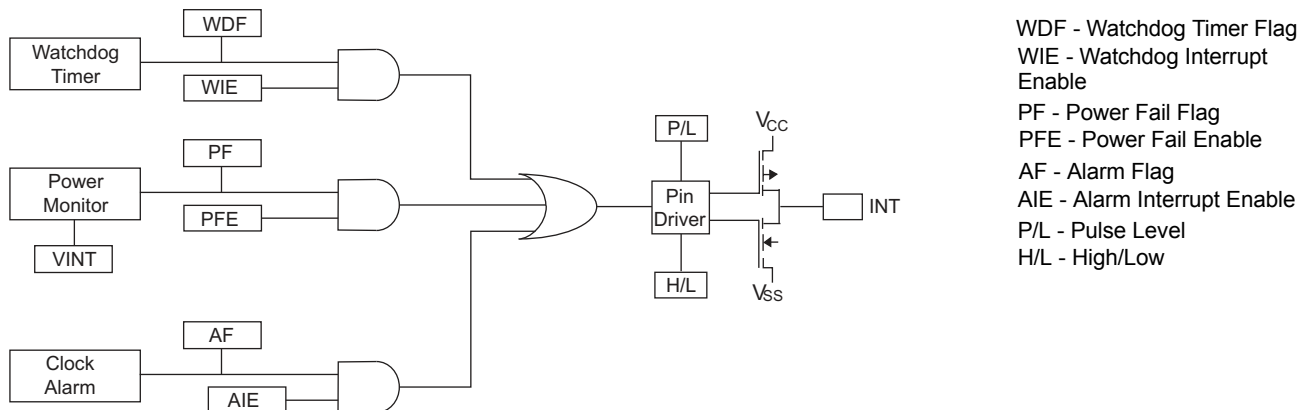

### RTC External Components

The RTC requires connecting an external 32.768 kHz crystal and  $C_1$ ,  $C_2$  load capacitance as shown in the Figure 5. The figure shows the recommended RTC external component values. The

load capacitances  $C_1$  and  $C_2$  are inclusive of parasitic of the printed circuit board (PCB). The PCB parasitic includes the capacitance due to land pattern of crystal pads/pins,  $X_{in}/X_{out}$  pads and copper traces connecting crystal and device pins.

**Figure 5. RTC Recommended Component Configuration** [12]

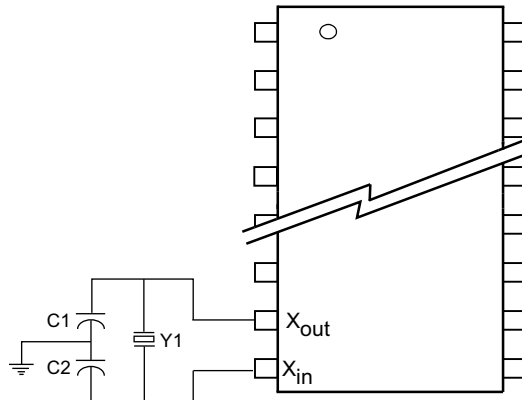

#### Recommended Values

$Y_1 = 32.768 \text{ kHz (12.5 pF)}$

$C_1 = 10 \text{ pF}$

$C_2 = 67 \text{ pF}$

**Note:** The recommended values for  $C_1$  and  $C_2$  include board trace capacitance.

#### Note

12. For nonvolatile static random access memory (nvSRAM) real time clock (RTC) design guidelines and best practices, see application note [AN61546](#).

## PCB Design Considerations for RTC

RTC crystal oscillator is a low current circuit with high impedance nodes on their crystal pins. Due to lower timekeeping current of RTC, the crystal connections are very sensitive to noise on the board. Hence it is necessary to isolate the RTC circuit from other signals on the board.

It is also critical to minimize the stray capacitance on the PCB. Stray capacitances add to the overall crystal load capacitance and therefore cause oscillation frequency errors. Proper bypassing and careful layout are required to achieve the optimum RTC performance.

### Layout requirements

The board layout must adhere to (but not limited to) the following guidelines during routing RTC circuitry. Following these guidelines help you achieve optimum performance from the RTC design.

- It is important to place the crystal as close as possible to the  $X_{in}$  and  $X_{out}$  pins. Keep the trace lengths between the crystal and RTC equal in length and as short as possible to reduce the probability of noise coupling by reducing the length of the antenna.

- Keep  $X_{in}$  and  $X_{out}$  trace width lesser than 8 mils. Wider trace width leads to larger trace capacitance. The larger these bond pads and traces are, the more likely it is that noise can couple from adjacent signals.
- Shield the  $X_{in}$  and  $X_{out}$  signals by providing a guard ring around the crystal circuitry. This guard ring prevents noise coupling from neighboring signals.
- Take care while routing any other high speed signal in the vicinity of RTC traces. The more the crystal is isolated from other signals on the board, the less likely it is that noise is coupled into the crystal. Maintain a minimum of 200 mil separation between the  $X_{in}$ ,  $X_{out}$  traces and any other high speed signal on the board.
- No signals should run underneath crystal components on the same PCB layer.

Create an isolated solid copper plane on adjacent PCB layer and underneath the crystal circuitry to prevent unwanted noise coupled from traces routed on the other signal layers of the PCB. The local plane should be separated by at least 40 mils from the neighboring plane on the same PCB layer. The solid plane should be in the vicinity of RTC components only and its perimeter should be kept equal to the guard ring perimeter. [Figure 6](#) shows the recommended layout for RTC circuit.

Figure 6. Recommended Layout for RTC

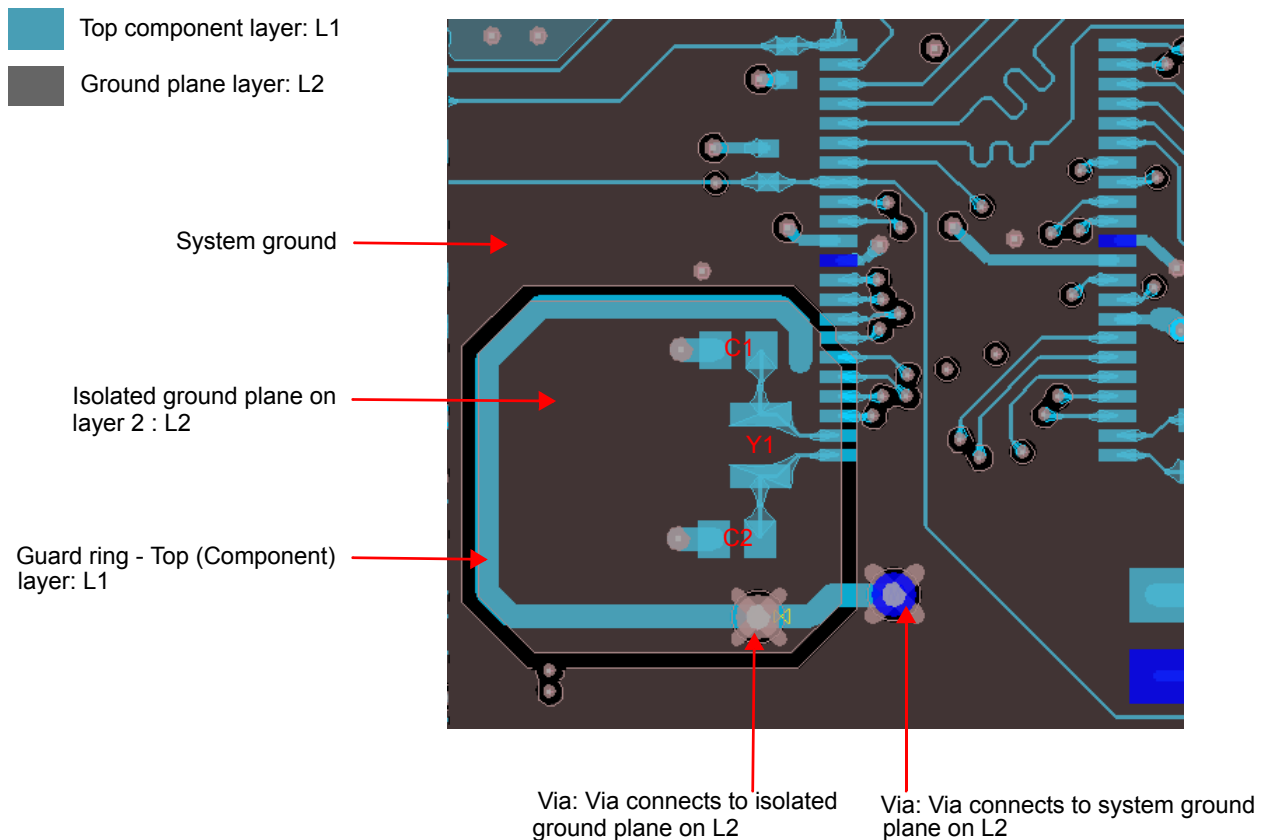

**Table 3. RTC Register Map** <sup>[13, 14, 15]</sup>

Register		BCD Format Data <sup>[14]</sup>								Function/Range
CY14B101KA	CY14B101MA	D7	D6	D5	D4	D3	D2	D1	D0	
0x1FFFF	0x0FFFF	10s years				Years				Years: 00–99
0x1FFFE	0x0FFFE	0	0	0	10s months	Months				Months: 01–12
0x1FFFD	0x0FFFD	0	0	10s day of month		Day of month				Day of month: 01–31
0x1FFFC	0x0FFFC	0	0	0	0	0	Day of week			Day of week: 01–07
0x1FFFB	0x0FFFB	0	0	10s hours		Hours				Hours: 00–23
0x1FFFA	0x0FFFA	0	10s minutes			Minutes				Minutes: 00–59
0x1FFF9	0x0FFF9	0	10s seconds			Seconds				Seconds: 00–59
0x1FFF8	0x0FFF8	OSCEN (0)	0	Cal sign (0)	Calibration (00000)					Calibration values <sup>[16]</sup>
0x1FFF7	0x0FFF7	WDS (0)	WDW (0)	WDT (000000)						Watchdog <sup>[16]</sup>
0x1FFF6	0x0FFF6	WIE (0)	AIE (0)	PFE (0)	0	H/L (1)	P/L (0)	0	0	Interrupts <sup>[16]</sup>
0x1FFF5	0x0FFF5	M (1)	0	10s alarm date		Alarm day				Alarm, day of month: 01–31
0x1FFF4	0x0FFF4	M (1)	0	10s alarm hours		Alarm hours				Alarm, hours: 00–23
0x1FFF3	0x0FFF3	M (1)	10s alarm minutes			Alarm minutes				Alarm, minutes: 00–59
0x1FFF2	0x0FFF2	M (1)	10s alarm seconds			Alarm, seconds				Alarm, seconds: 00–59
0x1FFF1	0x0FFF1	10s centuries				Centuries				Centuries: 00–99
0x1FFF0	0x0FFF0	WDF	AF	PF	OSCF <sup>[17]</sup>	0	CAL (0)	W (0)	R (0)	Flags <sup>[16]</sup>

**Notes**

13. Upper byte D15–D8 (CY14B101MA) of RTC registers are reserved for future use.  
 14. The unused bits of RTC registers are reserved for future use and should be set to '0'.  
 15. (.) designates values shipped from the factory.  
 16. This is a binary value, not a BCD value.  
 17. When user resets OSCF flag bit, the flags register will be updated after  $t_{RTCp}$  time.

**Table 4. Register Map Detail**

Register		Description							
CY14B101KA	CY14B101MA								
0x1FFFF	0x0FFFF	<b>Time Keeping - Years</b>							
		D7	D6	D5	D4	D3	D2	D1	D0
		10s years				Years			
		Contains the lower two BCD digits of the year. Lower nibble (four bits) contains the value for years; upper nibble (four bits) contains the value for 10s of years. Each nibble operates from 0 to 9. The range for the register is 0–99.							
0x1FFFE	0x0FFFE	<b>Time Keeping - Months</b>							
		D7	D6	D5	D4	D3	D2	D1	D0
		0	0	0	10s month	Months			
		Contains the BCD digits of the month. Lower nibble (four bits) contains the lower digit and operates from 0 to 9; upper nibble (one bit) contains the upper digit and operates from 0 to 1. The range for the register is 1–12.							
0x1FFFD	0x0FFFD	<b>Time Keeping - Date</b>							
		D7	D6	D5	D4	D3	D2	D1	D0
		0	0	10s day of month		Day of month			
		Contains the BCD digits for the date of the month. Lower nibble (four bits) contains the lower digit and operates from 0 to 9; upper nibble (two bits) contains the 10s digit and operates from 0 to 3. The range for the register is 1–31. Leap years are automatically adjusted for.							
0x1FFFC	0x0FFFC	<b>Time Keeping - Day</b>							
		D7	D6	D5	D4	D3	D2	D1	D0
		0	0	0	0	0	Day of week		
		Lower nibble (three bits) contains a value that correlates to day of the week. Day of the week is a ring counter that counts from 1 to 7 then returns to 1. The user must assign meaning to the day value, because the day is not integrated with the date.							
0x1FFFB	0x0FFFB	<b>Time Keeping - Hours</b>							
		D7	D6	D5	D4	D3	D2	D1	D0
		0	0	10s hours		Hours			
		Contains the BCD value of hours in 24 hour format. Lower nibble (four bits) contains the lower digit and operates from 0 to 9; upper nibble (two bits) contains the upper digit and operates from 0 to 2. The range for the register is 0–23.							
0x1FFFA	0x0FFFA	<b>Time Keeping - Minutes</b>							
		D7	D6	D5	D4	D3	D2	D1	D0
		0	10s minutes			Minutes			
		Contains the BCD value of minutes. Lower nibble (four bits) contains the lower digit and operates from 0 to 9; upper nibble (three bits) contains the upper minutes digit and operates from 0 to 5. The range for the register is 0–59.							
0x1FFF9	0x0FFF9	<b>Time Keeping - Seconds</b>							
		D7	D6	D5	D4	D3	D2	D1	D0
		0	10s seconds			Seconds			
		Contains the BCD value of seconds. Lower nibble (four bits) contains the lower digit and operates from 0 to 9; upper nibble (three bits) contains the upper digit and operates from 0 to 5. The range for the register is 0–59.							

**Table 4. Register Map Detail** (continued)

Register		Description							
CY14B101KA	CY14B101MA								
0x1FFF8	0x0FFF8	<b>Calibration/Control</b>							
		D7	D6	D5	D4	D3	D2	D1	D0
		OSCEN	0	Calibration sign	Calibration				
OSCEN		Oscillator enable. When set to '1', the oscillator is stopped. When set to '0', the oscillator runs. Disabling the oscillator saves battery or capacitor power during storage.							
Calibration Sign		Determines if the calibration adjustment is applied as an addition (1) to or as a subtraction (0) from the time-base.							
Calibration		These five bits control the calibration of the clock.							
0x1FFF7	0x0FFF7	<b>WatchDog Timer</b>							
		D7	D6	D5	D4	D3	D2	D1	D0
		WDS	WDW	WDT					
WDS		Watchdog strobe. Setting this bit to '1' reloads and restarts the watchdog timer. Setting the bit to '0' has no effect. The bit is cleared automatically after the watchdog timer is reset. The WDS bit is write only. Reading it always returns a 0.							
WDW		Watchdog write enable. Setting this bit to 1 disables any WRITE to the watchdog timeout value (D5–D0). This allows the user to set the watchdog strobe bit without disturbing the timeout value. Setting this bit to '0' allows bits D5–D0 to be written to the watchdog register when the next write cycle is complete. This function is explained in more detail in <a href="#">Watchdog Timer on page 10</a> .							
WDT		Watchdog timeout selection. The watchdog timer interval is selected by the 6-bit value in this register. It represents a multiplier of the 32 Hz count (31.25 ms). The range of timeout value is 31.25 ms (a setting of 1) to 2 seconds (setting of 3 Fh). Setting the watchdog timer register to 0 disables the timer. These bits can be written only if the WDW bit was set to 0 on a previous cycle.							
0x1FFF6	0x0FFF6	<b>Interrupt Status/Control</b>							
		D7	D6	D5	D4	D3	D2	D1	D0
		WIE	AIE	PFE	0	H/L	P/L	0	0
WIE		Watchdog interrupt enable. When set to '1' and a watchdog timeout occurs, the watchdog timer drives the INT pin and the WDF flag. When set to '0', the watchdog timeout affects only the WDF flag.							
AIE		Alarm interrupt enable. When set to '1', the alarm match drives the INT pin and the AF flag. When set to '0', the alarm match only affects the AF flag.							
PFE		Power fail enable. When set to '1', the power fail monitor drives the INT pin and the PF flag. When set to '0', the power fail monitor affects only the PF flag.							
0		Reserved for future use							
H/L		High/Low. When set to '1', the INT pin is driven active HIGH. When set to '0', the INT pin is open drain, active LOW.							
P/L		Pulse/Level. When set to '1', the INT pin is driven active (determined by H/L) by an interrupt source for approximately 200 ms. When set to '0', the INT pin is driven to an active level (as set by H/L) until the flags register is read.							
0x1FFF5	0x0FFF5	<b>Alarm - Day</b>							
		D7	D6	D5	D4	D3	D2	D1	D0
		M	0	10s alarm date			Alarm date		
		Contains the alarm value for the date of the month and the mask bit to select or deselect the date value.							
M		Match. When this bit is set to '0', the date value is used in the alarm match. Setting this bit to '1' causes the match circuit to ignore the date value.							



**Table 4. Register Map Detail** (continued)

Register		Description							
CY14B101KA	CY14B101MA								
0x1FFF4	0x0FFF4	<b>Alarm - Hours</b>							
		D7	D6	D5	D4	D3	D2	D1	D0
		M	0	10s alarm hours			Alarm hours		
		Contains the alarm value for the hours and the mask bit to select or deselect the hours value.							
M		Match. When this bit is set to '0', the hours value is used in the alarm match. Setting this bit to '1' causes the match circuit to ignore the hours value.							
0x1FFF3	0x0FFF3	<b>Alarm - Minutes</b>							
		D7	D6	D5	D4	D3	D2	D1	D0
		M	10s alarm minutes			Alarm minutes			
		Contains the alarm value for the minutes and the mask bit to select or deselect the minutes value.							
M		Match. When this bit is set to '0', the minutes value is used in the alarm match. Setting this bit to '1' causes the match circuit to ignore the minutes value.							
0x1FFF2	0x0FFF2	<b>Alarm - Seconds</b>							
		D7	D6	D5	D4	D3	D2	D1	D0
		M	10s alarm seconds			Alarm seconds			
		Contains the alarm value for the seconds and the mask bit to select or deselect the seconds' value.							
M		Match. When this bit is set to '0', the seconds value is used in the alarm match. Setting this bit to '1' causes the match circuit to ignore the seconds value.							
0x1FFF1	0x0FFF1	<b>Time Keeping - Centuries</b>							
		D7	D6	D5	D4	D3	D2	D1	D0
		10s centuries				Centuries			
		Contains the BCD value of centuries. Lower nibble contains the lower digit and operates from 0 to 9; upper nibble contains the upper digit and operates from 0 to 9. The range for the register is 0–99 centuries.							
0x1FFF0	0x0FFF0	<b>Flags</b>							
		D7	D6	D5	D4	D3	D2	D1	D0
		WDF	AF	PF	OSCF	0	CAL	W	R
WDF		Watchdog timer flag. This read only bit is set to '1' when the watchdog timer is allowed to reach 0 without being reset by the user. It is cleared to 0 when the flags register is read or on power-up.							
AF		Alarm flag. This read only bit is set to '1' when the time and date match the values stored in the alarm registers with the match bits = 0. It is cleared when the flags register is read or on power-up.							
PF		Power fail flag. This read only bit is set to '1' when power falls below the power fail threshold $V_{SWITCH}$ . It is cleared to 0 when the flags register is read or on power-up.							
OSCF		Oscillator fail flag. Set to '1' on power-up if the oscillator is enabled and not running in the first 5 ms of operation. This indicates that RTC backup power failed and clock value is no longer valid. This bit survives the power cycle and is never cleared internally by the chip. The user must check for this condition and write '0' to clear this flag. When user resets OSCF flag bit, the bit will be updated after $t_{RTCp}$ time.							
CAL		Calibration mode. When set to '1', a 512 Hz square wave is output on the INT pin. When set to '0', the INT pin resumes normal operation. This bit defaults to '0' (disabled) on power-up.							
W		Write enable: Setting the 'W' bit to '1' freezes updates of the RTC registers. The user can then write to RTC registers, alarm registers, calibration register, interrupt register and flags register. Setting the 'W' bit to '0' causes the contents of the RTC registers to be transferred to the time keeping counters if the time has changed. This transfer process takes $t_{RTCp}$ time to complete. This bit defaults to 0 on power-up.							
R		Read enable: Setting 'R' bit to '1', stops clock updates to user RTC registers so that clock updates are not seen during the reading process. Set 'R' bit to '0' to resume clock updates to the holding register. Setting this bit does not require 'W' bit to be set to '1'. This bit defaults to 0 on power-up.							

## Maximum Ratings

Exceeding maximum ratings may impair the useful life of the device. These user guidelines are not tested.

Storage temperature	-65 °C to +150 °C
Maximum accumulated storage time	
At 150 °C ambient temperature	1000 h
At 85 °C ambient temperature	20 Years
Maximum junction temperature	150 °C
Supply voltage on V <sub>CC</sub> relative to V <sub>SS</sub>	-0.5 V to 4.1 V
Voltage applied to outputs in High Z state	-0.5 V to V <sub>CC</sub> + 0.5 V
Input voltage	-0.5 V to V <sub>CC</sub> + 0.5 V

Transient voltage (< 20 ns) on any pin to ground potential	-2.0 V to V <sub>CC</sub> + 2.0 V
Package power dissipation capability (T <sub>A</sub> = 25 °C)	1.0 W
Surface mount Pb soldering temperature (3 seconds)	+260 °C
DC output current (1 output at a time, 1s duration)	15 mA
Static discharge voltage (per MIL-STD-883, Method 3015)	> 2001 V
Latch up current	> 200 mA

## Operating Range

Range	Ambient Temperature	V <sub>CC</sub>
Industrial	-40 °C to +85 °C	2.7 V to 3.6 V

## DC Electrical Characteristics

Over the [Operating Range](#)

Parameter	Description	Test Conditions	Min	Typ <sup>[18]</sup>	Max	Unit
V <sub>CC</sub>	Power supply voltage		2.7	3.0	3.6	V
I <sub>CC1</sub>	Average V <sub>CC</sub> current	t <sub>RC</sub> = 25 ns t <sub>RC</sub> = 45 ns Values obtained without output loads (I <sub>OUT</sub> = 0 mA)	-	-	70 52	mA mA
I <sub>CC2</sub>	Average V <sub>CC</sub> current during STORE	All inputs don't care, V <sub>CC</sub> = Max. Average current for duration t <sub>STORE</sub>	-	-	10	mA
I <sub>CC3</sub> <sup>[18]</sup>	Average V <sub>CC</sub> current at t <sub>RC</sub> = 200 ns, V <sub>CC(Typ)</sub> , 25 °C	All inputs cycling at CMOS levels. Values obtained without output loads (I <sub>OUT</sub> = 0 mA).	-	35	-	mA
I <sub>CC4</sub>	Average V <sub>CAP</sub> current during AutoStore cycle	All inputs don't care. Average current for duration t <sub>STORE</sub>	-	-	5	mA
I <sub>SB</sub>	V <sub>CC</sub> standby current	$\overline{CE} \geq (V_{CC} - 0.2 V)$ . $V_{IN} \leq 0.2 V$ or $\geq (V_{CC} - 0.2 V)$ . W bit set to '0'. Standby current level after nonvolatile cycle is complete. Inputs are static. f = 0 MHz.	-	-	5	mA
I <sub>IX</sub> <sup>[19]</sup>	Input leakage current (except HSB)	V <sub>CC</sub> = Max, V <sub>SS</sub> ≤ V <sub>IN</sub> ≤ V <sub>CC</sub>	-1	-	+1	μA
	Input leakage current (for HSB)	V <sub>CC</sub> = Max, V <sub>SS</sub> ≤ V <sub>IN</sub> ≤ V <sub>CC</sub>	-100	-	+1	μA
I <sub>OZ</sub>	Off state output leakage current	V <sub>CC</sub> = Max, V <sub>SS</sub> ≤ V <sub>OUT</sub> ≤ V <sub>CC</sub> . $\overline{CE}$ or $\overline{OE} \geq V_{IH}$ or $\overline{BHE}/\overline{BLE} \geq V_{IH}$ or $\overline{WE} \leq V_{IL}$	-1	-	+1	μA
V <sub>IH</sub>	Input HIGH voltage		2.0	-	V <sub>CC</sub> + 0.5	V
V <sub>IL</sub>	Input LOW voltage		V <sub>SS</sub> - 0.5	-	0.8	V
V <sub>OH</sub>	Output HIGH voltage	I <sub>OUT</sub> = -2 mA	2.4	-	-	V
V <sub>OL</sub>	Output LOW voltage	I <sub>OUT</sub> = 4 mA	-	-	0.4	V

### Notes

18. Typical values are at 25 °C, V<sub>CC</sub> = V<sub>CC(Typ)</sub>. Not 100% tested.

19. The HSB pin has I<sub>OUT</sub> = -2 μA for V<sub>OH</sub> of 2.4 V when both active HIGH and low drivers are disabled. When they are enabled standard V<sub>OH</sub> and V<sub>OL</sub> are valid. This parameter is characterized but not tested.

## DC Electrical Characteristics (continued)

Over the [Operating Range](#)

Parameter	Description	Test Conditions	Min	Typ <sup>[18]</sup>	Max	Unit
$V_{CAP}^{[20]}$	Storage capacitor	Between $V_{CAP}$ pin and $V_{SS}$	61	68	180	$\mu\text{F}$
$V_{VCAP}^{[21, 22]}$	Maximum voltage driven on $V_{CAP}$ pin by the device	$V_{CC} = \text{Max}$	–	–	$V_{CC}$	V

## Data Retention and Endurance

Over the [Operating Range](#)

Parameter	Description	Min	Unit
$\text{DATA}_R$	Data retention	20	Years
$\text{NV}_C$	Nonvolatile STORE operations	1,000	K

## Capacitance

Parameter <sup>[22]</sup>	Description	Test Conditions	Max	Unit
$C_{IN}$	Input capacitance (except $\overline{\text{BHE}}$ , $\overline{\text{BLE}}$ and $\overline{\text{HSB}}$ )	$T_A = 25^\circ\text{C}$ , $f = 1\text{ MHz}$ , $V_{CC} = V_{CC(\text{Typ})}$	7	pF
	Input capacitance (for $\overline{\text{BHE}}$ , $\overline{\text{BLE}}$ and $\overline{\text{HSB}}$ )		8	pF
$C_{OUT}$	Output capacitance (except $\overline{\text{HSB}}$ )		7	pF
	Output capacitance (for $\overline{\text{HSB}}$ )		8	pF

## Thermal Resistance

Parameter <sup>[22]</sup>	Description	Test Conditions	48-pin SSOP	44-pin TSOP II	54-pin TSOP II	Unit
$\Theta_{JA}$	Thermal resistance (junction to ambient)	Test conditions follow standard test methods and procedures for measuring thermal impedance, in accordance with EIA/JESD51.	37.47	41.74	36.4	$^\circ\text{C/W}$
$\Theta_{JC}$	Thermal resistance (junction to case)		24.71	11.90	10.13	$^\circ\text{C/W}$

### Notes

20. Min  $V_{CAP}$  value guarantees that there is a sufficient charge available to complete a successful AutoStore operation. Max  $V_{CAP}$  value guarantees that the capacitor on  $V_{CAP}$  is charged to a minimum voltage during a Power-Up RECALL cycle so that an immediate power-down cycle can complete a successful AutoStore. Therefore it is always recommended to use a capacitor within the specified min and max limits. See application note [AN43593](#) for more details on  $V_{CAP}$  options.
21. Maximum voltage on  $V_{CAP}$  pin ( $V_{VCAP}$ ) is provided for guidance when choosing the  $V_{CAP}$  capacitor. The voltage rating of the  $V_{CAP}$  capacitor across the operating temperature range should be higher than the  $V_{VCAP}$  voltage.
22. These parameters are guaranteed by design and are not tested.

## AC Test Loads

Figure 7. AC Test Loads

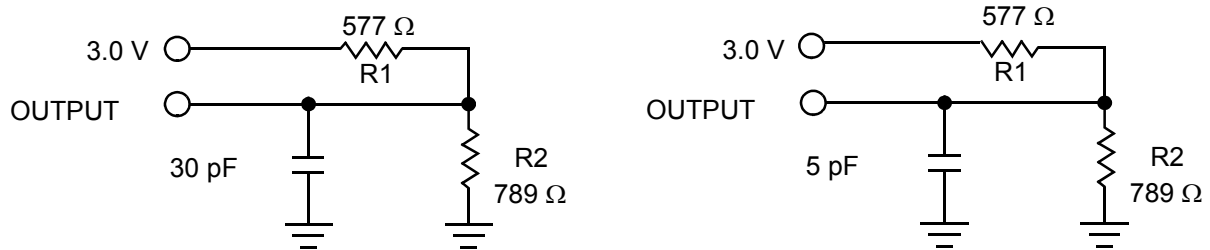

## AC Test Conditions

Input pulse levels ..... 0 V to 3 V  
 Input rise and fall times (10%–90%) ..... ≤ 3 ns  
 Input and output timing reference levels ..... 1.5 V

## RTC Characteristics

Over the [Operating Range](#)

Parameter	Description	Min	Typ <sup>[23]</sup>	Max	Units	
$V_{RTCbat}$	RTC battery pin voltage	1.8	3.0	3.6	V	
$I_{BAK}^{[24]}$	RTC backup current (Refer <a href="#">Figure 5</a> for the recommended external components for RTC)	$T_A$ (Min)	–	–	0.35	μA
		25 °C	–	0.35	–	μA
		$T_A$ (Max)	–	–	0.5	μA
$V_{RTCcap}^{[25]}$	RTC capacitor pin voltage	$T_A$ (Min)	1.6	–	3.6	V
		25 °C	1.5	3.0	3.6	V
		$T_A$ (Max)	1.4	–	3.6	V
$t_{OCS}$	RTC oscillator time to start	–	1	2	sec	
$t_{RTCp}$	RTC processing time from end of 'W' bit set to '0'	–	–	350	μs	
$R_{BKCHG}$	RTC backup capacitor charge current-limiting resistor	350	–	850	Ω	

### Notes

23. These parameters are guaranteed by design and are not tested.

24. From either  $V_{RTCcap}$  or  $V_{RTCbat}$ .

25. If  $V_{RTCcap} > 0.5$  V or if no capacitor is connected to  $V_{RTCcap}$  pin, the oscillator starts in  $t_{OCS}$  time. If a backup capacitor is connected and  $V_{RTCcap} < 0.5$  V, the capacitor must be allowed to charge to 0.5 V for oscillator to start.

## AC Switching Characteristics

Over the [Operating Range](#)

Parameters <sup>[26]</sup>		Description	25 ns		45 ns		Unit
Cypress Parameter	Alt Parameter		Min	Max	Min	Max	
<b>SRAM Read Cycle</b>							
$t_{ACE}$	$t_{ACS}$	Chip enable access time	–	25	–	45	ns
$t_{RC}^{[27]}$	$t_{RC}$	Read cycle time	25	–	45	–	ns
$t_{AA}^{[28]}$	$t_{AA}$	Address access time	–	25	–	45	ns
$t_{DOE}$	$t_{OE}$	Output enable to data valid	–	12	–	20	ns
$t_{OHA}^{[28]}$	$t_{OH}$	Output hold after address change	3	–	3	–	ns
$t_{LZCE}^{[29, 30]}$	$t_{LZ}$	Chip enable to output active	3	–	3	–	ns
$t_{HZCE}^{[29, 30]}$	$t_{HZ}$	Chip disable to output inactive	–	10	–	15	ns
$t_{LZOE}^{[29, 30]}$	$t_{OLZ}$	Output enable to output active	0	–	0	–	ns
$t_{HZOE}^{[29, 30]}$	$t_{OHZ}$	Output disable to output inactive	–	10	–	15	ns
$t_{PU}^{[29]}$	$t_{PA}$	Chip enable to power active	0	–	0	–	ns
$t_{PD}^{[29]}$	$t_{PS}$	Chip disable to power standby	–	25	–	45	ns
$t_{DBE}$	–	Byte enable to data valid	–	12	–	20	ns
$t_{LZBE}^{[29]}$	–	Byte enable to output active	0	–	0	–	ns
$t_{HZBE}^{[29]}$	–	Byte disable to output inactive	–	10	–	15	ns
<b>SRAM Write Cycle</b>							
$t_{WC}$	$t_{WC}$	Write cycle time	25	–	45	–	ns
$t_{PWE}$	$t_{WP}$	Write pulse width	20	–	30	–	ns
$t_{SCE}$	$t_{CW}$	Chip enable to end of write	20	–	30	–	ns
$t_{SD}$	$t_{DW}$	Data setup to end of write	10	–	15	–	ns
$t_{HD}$	$t_{DH}$	Data hold after end of write	0	–	0	–	ns
$t_{AW}$	$t_{AW}$	Address setup to end of write	20	–	30	–	ns
$t_{SA}$	$t_{AS}$	Address setup to start of write	0	–	0	–	ns
$t_{HA}$	$t_{WR}$	Address hold after end of write	0	–	0	–	ns
$t_{HZWE}^{[29, 30, 31]}$	$t_{WZ}$	Write enable to output disable	–	10	–	15	ns
$t_{LZWE}^{[29, 30]}$	$t_{OW}$	Output active after end of write	3	–	3	–	ns
$t_{BW}$	–	Byte enable to end of write	20	–	30	–	ns

### Notes

26. Test conditions assume signal transition time of 3 ns or less, timing reference levels of  $V_{CC}/2$ , input pulse levels of 0 to  $V_{CC(typ)}$ , and output loading of the specified  $I_{OL}/I_{OH}$  and load capacitance shown in [Figure 7 on page 20](#).

27. WE must be HIGH during SRAM read cycles.

28. Device is continuously selected with  $\overline{CE}$ ,  $\overline{OE}$ , and  $\overline{BHE}/\overline{BLE}$  LOW.

29. These parameters are guaranteed by design and are not tested.

30. Measured  $\pm 200$  mV from steady state output voltage.

31. If WE is low when  $\overline{CE}$  goes low, the outputs remain in the high impedance state.

## Switching Waveforms

Figure 8. SRAM Read Cycle No. 1 (Address Controlled) [32, 33, 34]

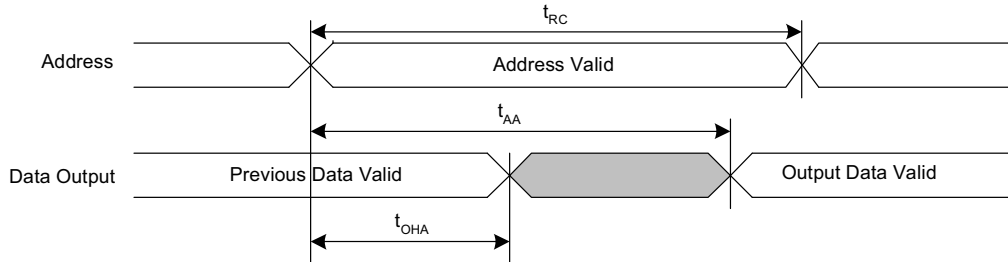
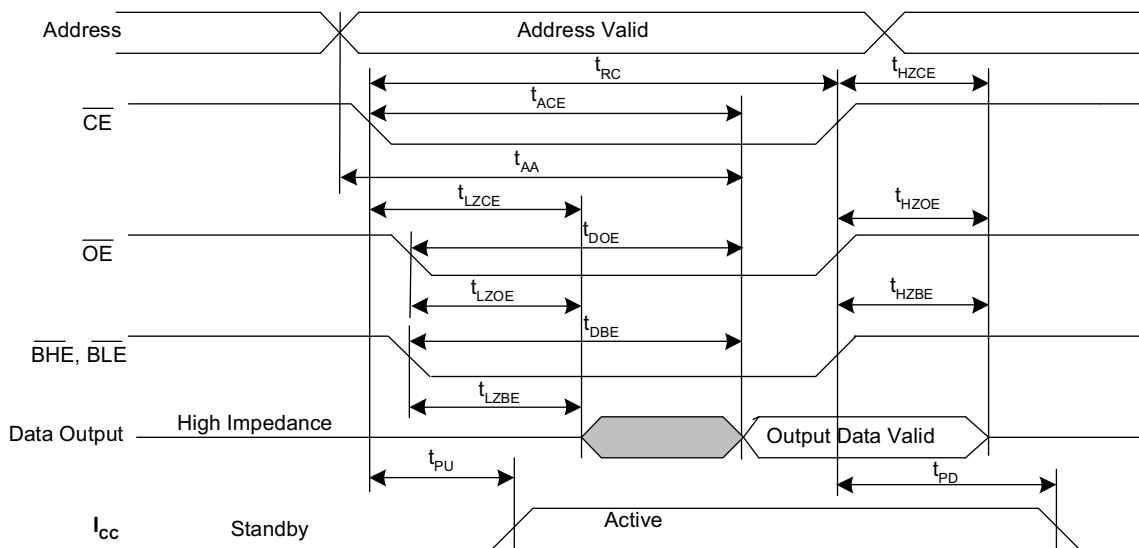

Figure 9. SRAM Read Cycle No. 2 ( $\overline{CE}$  and  $\overline{OE}$  Controlled) [32, 34, 35]



### Notes

- 32.  $\overline{WE}$  must be HIGH during SRAM read cycles.
- 33. Device is continuously selected with  $\overline{CE}$ ,  $\overline{OE}$ , and  $\overline{BHE}/\overline{BLE}$  LOW.
- 34.  $\overline{HSB}$  must remain HIGH during Read and Write cycles.
- 35.  $\overline{BHE}$  and  $\overline{BLE}$  are applicable for  $\times 16$  configuration only.

Switching Waveforms (continued)

Figure 10. SRAM Write Cycle No. 1 ( $\overline{WE}$  Controlled) [36, 37, 38, 39]

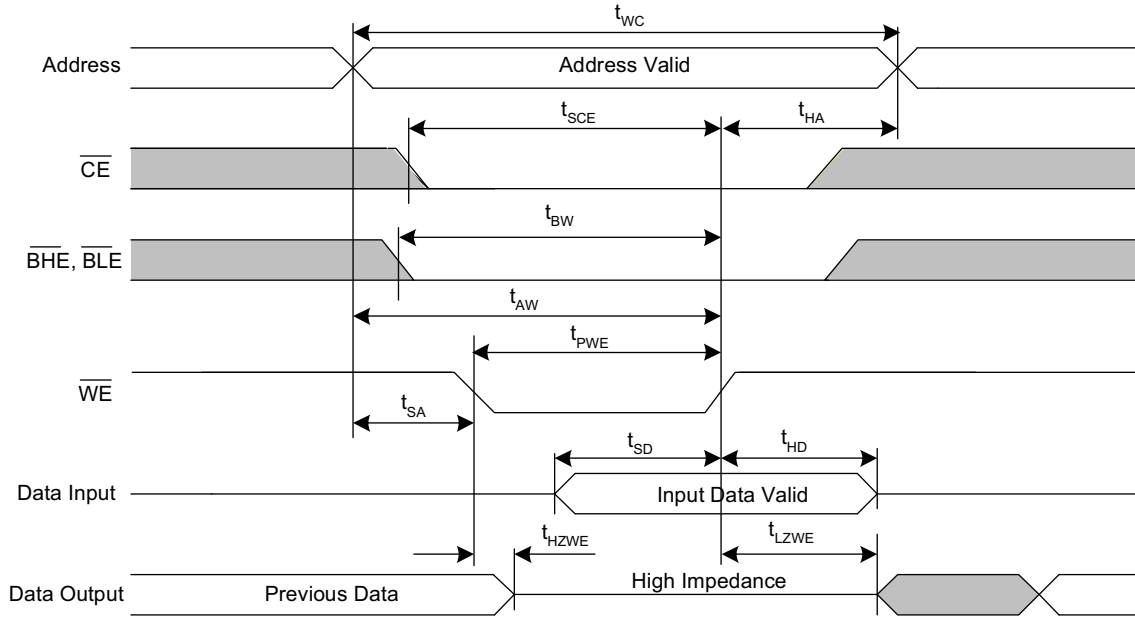
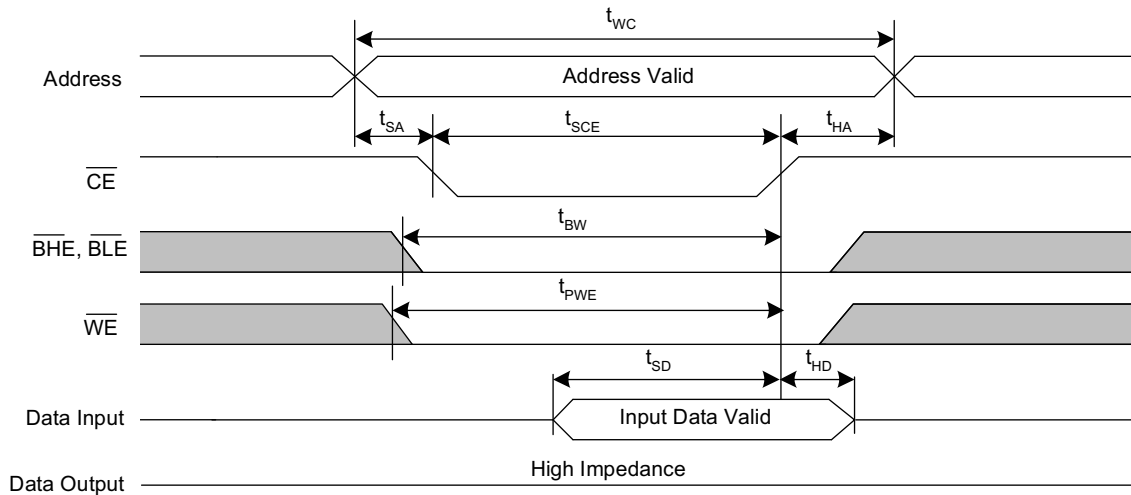

Figure 11. SRAM Write Cycle No. 2 ( $\overline{CE}$  Controlled) [36, 37, 38, 39]



Notes

- 36.  $\overline{BHE}$  and  $\overline{BLE}$  are applicable for  $\times 16$  configuration only.
- 37.  $\overline{HSB}$  must remain HIGH during read and write cycles.
- 38. If  $\overline{WE}$  is LOW when  $\overline{CE}$  goes LOW, the outputs remain in the high impedance state.
- 39.  $\overline{CE}$  or  $\overline{WE}$  must be  $\geq V_{IH}$  during address transitions.

Switching Waveforms (continued)

Figure 12. SRAM Write Cycle #3 ( $\overline{\text{BHE}}$  and  $\overline{\text{BLE}}$  Controlled) [40, 41, 42, 43, 44]

(Not applicable for RTC register writes)

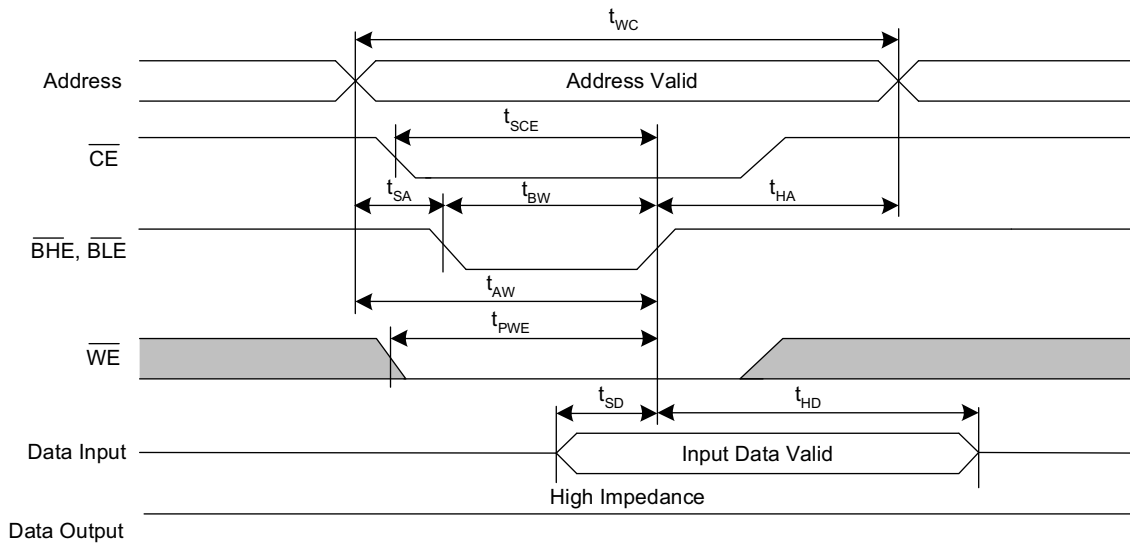

Notes

40. If  $\overline{\text{WE}}$  is LOW when  $\overline{\text{CE}}$  goes LOW, the outputs remain in the high impedance state.
41.  $\overline{\text{HSB}}$  must remain HIGH during read and write cycles.
42.  $\overline{\text{CE}}$  or  $\overline{\text{WE}}$  must be  $\geq V_{\text{IH}}$  during address transitions.
43. While there are 19 address lines on the CY14B101KA (18 address lines on the CY14B101MA), only 13 address lines ( $A_{14}$ – $A_2$ ) are used to control software modes. The remaining address lines are don't care.
44. Only  $\overline{\text{CE}}$  and  $\overline{\text{WE}}$  controlled writes to RTC registers are allowed.  $\overline{\text{BLE}}$  pin must be held LOW before  $\overline{\text{CE}}$  or  $\overline{\text{WE}}$  pin goes LOW for writes to RTC register.



## AutoStore/Power-Up RECALL

Over the [Operating Range](#)

Parameter	Description	CY14B101KA/CY14B101MA		Unit
		Min	Max	
$t_{HRECALL}$ [45]	Power-Up RECALL duration	–	20	ms
$t_{STORE}$ [46]	STORE cycle duration	–	8	ms
$t_{DELAY}$ [47]	Time allowed to complete SRAM write cycle	–	25	ns
$V_{SWITCH}$	Low voltage trigger level	–	2.65	V
$t_{VCCRRISE}$ [48]	$V_{CC}$ rise time	150	–	$\mu$ s
$V_{HDIS}$ [48]	$\overline{HSB}$ output disable voltage	–	1.9	V
$t_{LZHSB}$ [48]	$\overline{HSB}$ to output active time	–	5	$\mu$ s
$t_{HHHD}$ [48]	$\overline{HSB}$ high active time	–	500	ns

## Switching Waveforms

Figure 13. AutoStore or Power-Up RECALL [49]

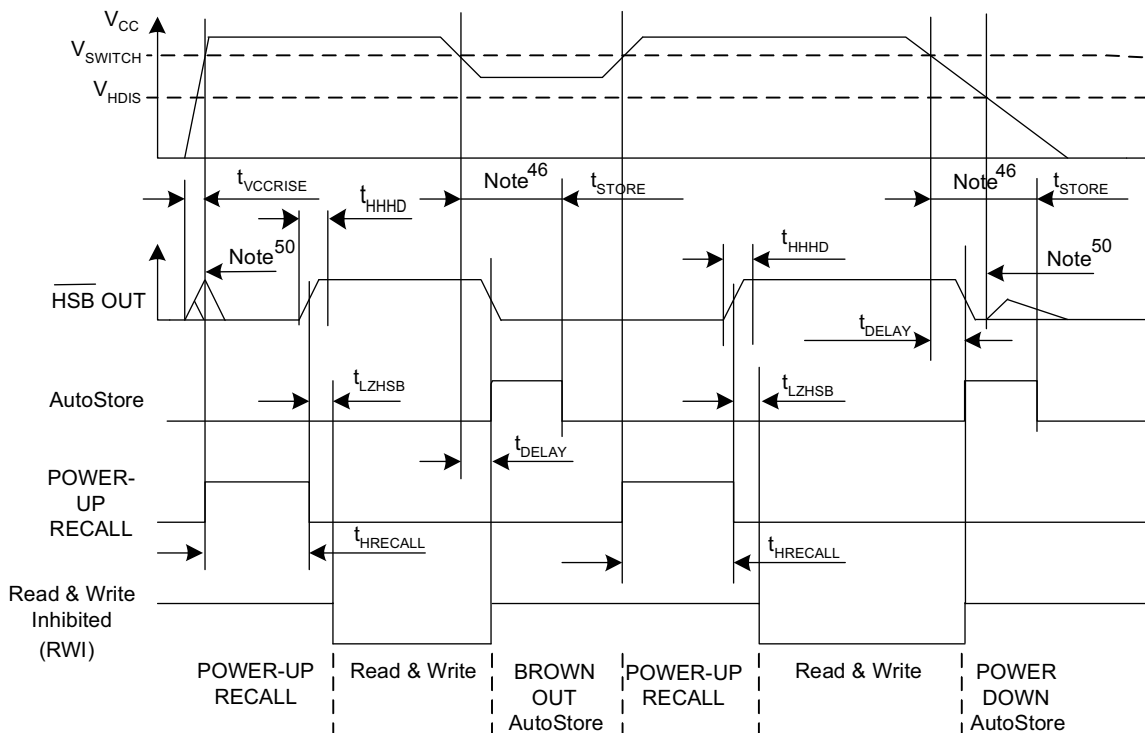

### Notes

- 45.  $t_{HRECALL}$  starts from the time  $V_{CC}$  rises above  $V_{SWITCH}$ .
- 46. If an SRAM write has not taken place since the last nonvolatile cycle, no AutoStore or Hardware STORE takes place.
- 47. On a Hardware STORE and AutoStore initiation, SRAM write operation continues to be enabled for time  $t_{DELAY}$ .
- 48. These parameters are guaranteed by design and are not tested.
- 49. Read and Write cycles are ignored during STORE, RECALL, and while  $V_{CC}$  is below  $V_{SWITCH}$ .
- 50. During power-up and power-down, HSB glitches when HSB pin is pulled up through an external resistor.

## Software Controlled STORE/RECALL Cycle

Over the [Operating Range](#)

Parameter [51, 52]	Description	25 ns		45 ns		Unit
		Min	Max	Min	Max	
$t_{RC}$	STORE/RECALL initiation cycle time	25	–	45	–	ns
$t_{SA}$	Address setup time	0	–	0	–	ns
$t_{CW}$	Clock pulse width	20	–	30	–	ns
$t_{HA}$	Address hold time	0	–	0	–	ns
$t_{RECALL}$	RECALL duration	–	200	–	200	$\mu$ s
$t_{SS}$ [53, 54]	Soft sequence processing time	–	100	–	100	$\mu$ s

## Switching Waveforms

Figure 14.  $\overline{CE}$  &  $\overline{OE}$  Controlled Software STORE/RECALL Cycle [52]

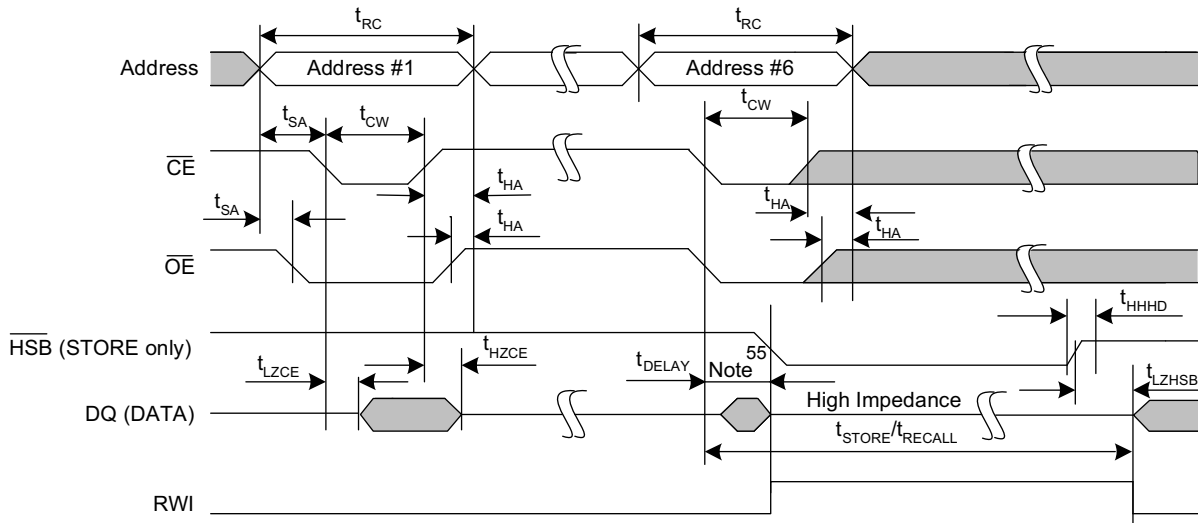
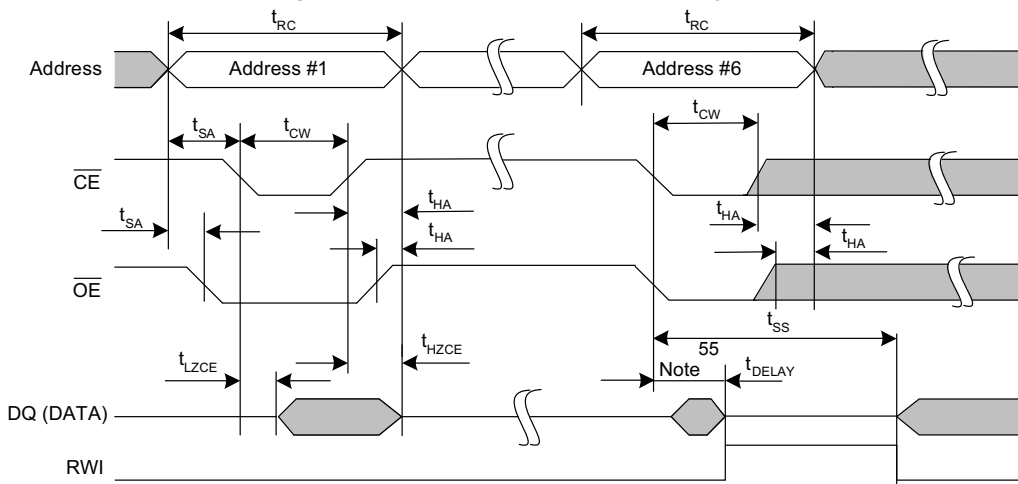

Figure 15. AutoStore Enable/Disable Cycle [52]



### Notes

51. The software sequence is clocked with  $\overline{CE}$  controlled or  $\overline{OE}$  controlled reads.
52. The six consecutive addresses must be read in the order listed in [Table 1 on page 7](#).  $\overline{WE}$  must be HIGH during all six consecutive cycles.
53. This is the amount of time it takes to take action on a soft sequence command.  $V_{CC}$  power must remain HIGH to effectively register command.
54. Commands such as STORE and RECALL lock out I/O until operation is complete which further increases this time. See the specific command.
55. DQ output data at the sixth read may be invalid since the output is disabled at  $t_{DELAY}$  time.

## Hardware STORE Cycle

Over the [Operating Range](#)

Parameter	Description	CY14B101KA/CY14B101MA		Unit
		Min	Max	
$t_{DHSB}$	HSB to output active time when write latch not set	–	25	ns
$t_{PHSB}$	Hardware STORE pulse width	15	–	ns

## Switching Waveforms

Figure 16. Hardware STORE Cycle <sup>[56]</sup>

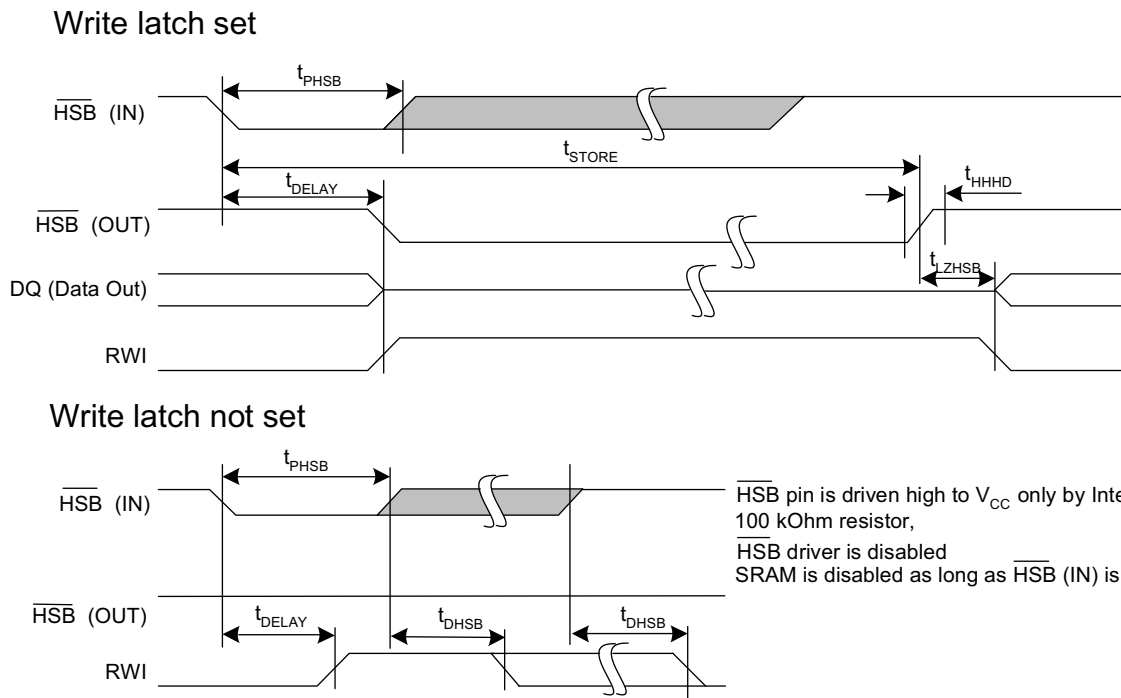
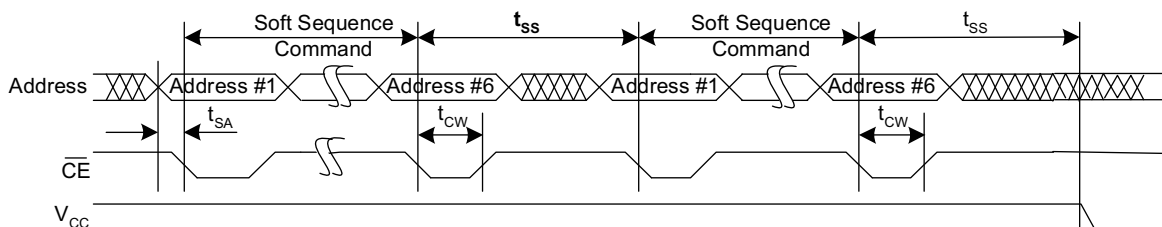

Figure 17. Soft Sequence Processing <sup>[57, 58]</sup>



### Notes

- 56. If an SRAM write has not taken place since the last nonvolatile cycle, no AutoStore or Hardware STORE takes place.
- 57. This is the amount of time it takes to take action on a soft sequence command.  $V_{CC}$  power must remain HIGH to effectively register command.
- 58. Commands such as STORE and RECALL lock out I/O until operation is complete which further increases this time. See the specific command.

## Truth Table for SRAM Operations

$\overline{\text{HSB}}$  must remain HIGH for SRAM operations.

**Table 5. Truth Table for × 8 Configuration**

$\overline{\text{CE}}$	$\overline{\text{WE}}$	$\overline{\text{OE}}$	Inputs/Outputs <sup>[59]</sup>	Mode	Power
H	X	X	High Z	Deselect/Power-down	Standby
L	H	L	Data out (DQ <sub>0</sub> –DQ <sub>7</sub> )	Read	Active
L	H	H	High Z	Output disabled	Active
L	L	X	Data in (DQ <sub>0</sub> –DQ <sub>7</sub> )	Write	Active

## Truth Table for SRAM Operations

$\overline{\text{HSB}}$  must remain HIGH for SRAM operations.

**Table 6. Truth Table for × 16 Configuration**

$\overline{\text{CE}}$	$\overline{\text{WE}}$	$\overline{\text{OE}}$	$\overline{\text{BHE}}$ <sup>[60]</sup>	$\overline{\text{BLE}}$ <sup>[60]</sup>	Inputs/Outputs <sup>[59]</sup>	Mode	Power
H	X	X	X	X	High Z	Deselect/Power-down	Standby
L	X	X	H	H	High Z	Output disabled	Active
L	H	L	L	L	Data out (DQ <sub>0</sub> –DQ <sub>15</sub> )	Read	Active
L	H	L	H	L	Data out (DQ <sub>0</sub> –DQ <sub>7</sub> ) DQ <sub>8</sub> –DQ <sub>15</sub> in High Z	Read	Active
L	H	L	L	H	Data out (DQ <sub>8</sub> –DQ <sub>15</sub> ) DQ <sub>0</sub> –DQ <sub>7</sub> in High Z	Read	Active
L	H	H	L	L	High Z	Output disabled	Active
L	H	H	H	L	High Z	Output disabled	Active
L	H	H	L	H	High Z	Output disabled	Active
L	L	X	L	L	Data in (DQ <sub>0</sub> –DQ <sub>15</sub> )	Write	Active
L	L	X	H	L	Data in (DQ <sub>0</sub> –DQ <sub>7</sub> ) DQ <sub>8</sub> –DQ <sub>15</sub> in High Z	Write	Active
L	L	X	L	H	Data in (DQ <sub>8</sub> –DQ <sub>15</sub> ) DQ <sub>0</sub> –DQ <sub>7</sub> in High Z	Write	Active

### Notes

59. Data DQ<sub>0</sub>–DQ<sub>7</sub> for × 8 configuration and Data DQ<sub>0</sub>–DQ<sub>15</sub> for × 16 configuration.

60. BHE and BLE are applicable for × 16 configuration only.

## Ordering Information

Cypress offers other versions of this type of product in many different configurations and features. The below table contains only the list of parts that are currently available. For a complete listing of all options, visit the Cypress website at [www.cypress.com](http://www.cypress.com) and see the product summary page at <http://www.cypress.com/products> or contact your local sales representative. Cypress maintains a worldwide network of offices, solution centers, manufacturer's representatives and distributors. To find the office closest to you, visit us at <http://www.cypress.com/go/datasheet/offices>.

Speed (ns)	Ordering Code	Package Diagram	Package Type	Operating Range
25	CY14B101KA-ZS25XIT	51-85087	44-pin TSOP II	Industrial
	CY14B101KA-ZS25XI	51-85087	44-pin TSOP II	
	CY14B101KA-SP25XIT	51-85061	48-pin SSOP	
	CY14B101KA-SP25XI	51-85061	48-pin SSOP	
45	CY14B101KA-ZS45XIT	51-85087	44-pin TSOP II	
	CY14B101KA-ZS45XI	51-85087	44-pin TSOP II	
	CY14B101KA-SP45XIT	51-85061	48-pin SSOP	
	CY14B101KA-SP45XI	51-85061	48-pin SSOP	

All the above parts are Pb-free.

## Ordering Code Definitions

### CY 14 B 101 K A - ZS 25 X I T

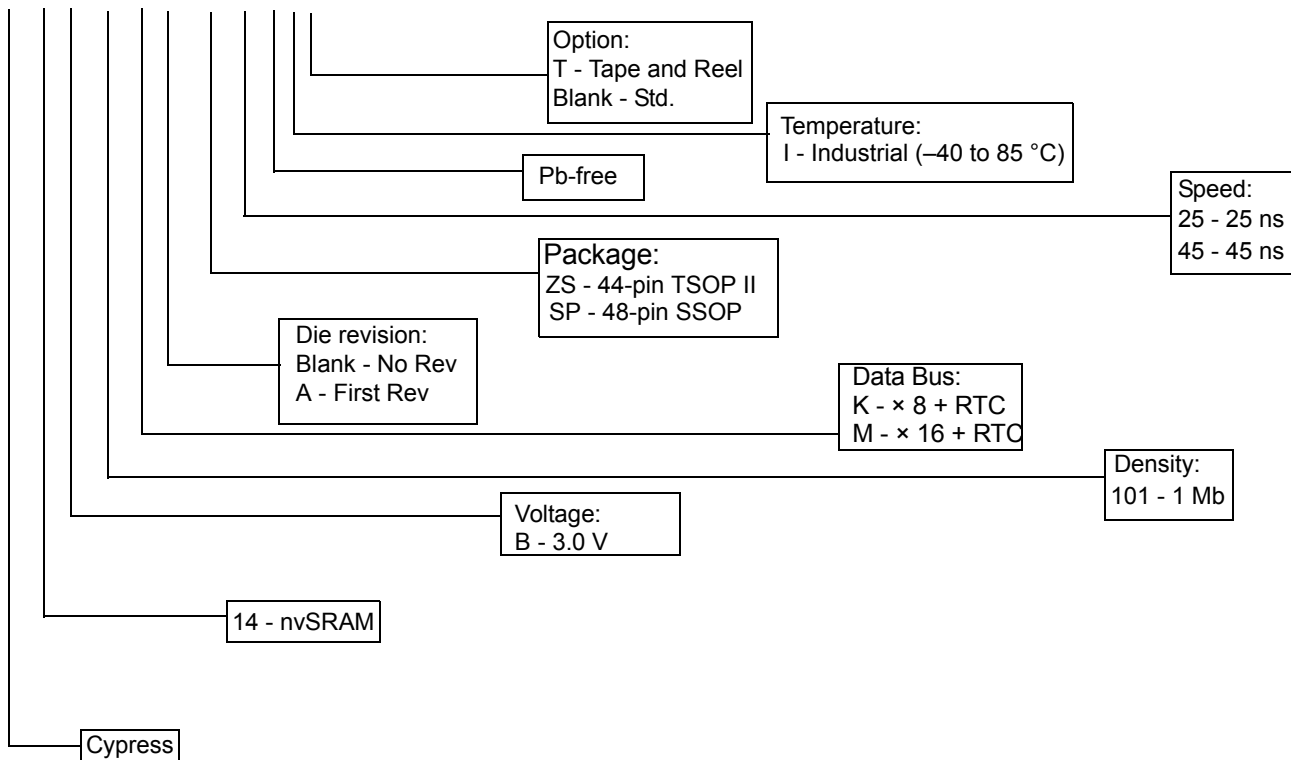

**Package Diagrams**

**Figure 18. 44-pin TSOP II Package Outline, 51-85087**

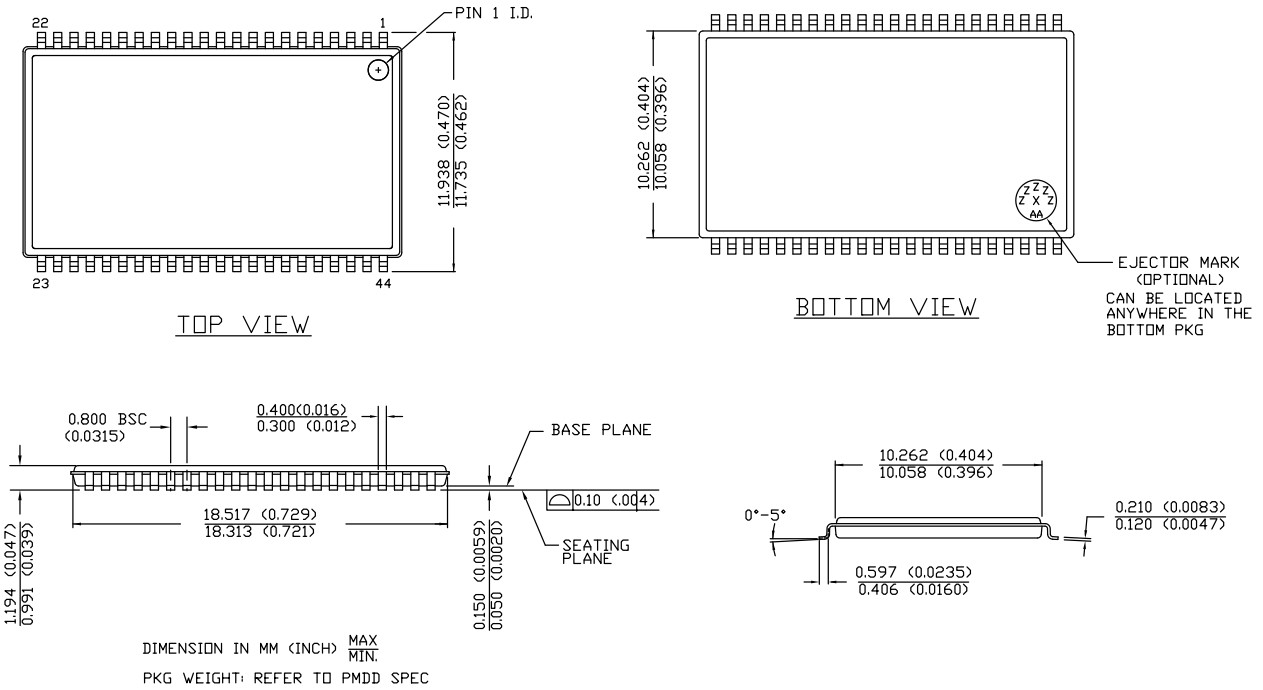

51-85087 \*E

**Package Diagrams** (continued)

**Figure 19. 54-pin TSOP II (22.4 × 11.84 × 1.0 mm) Package Outline, 51-85160**

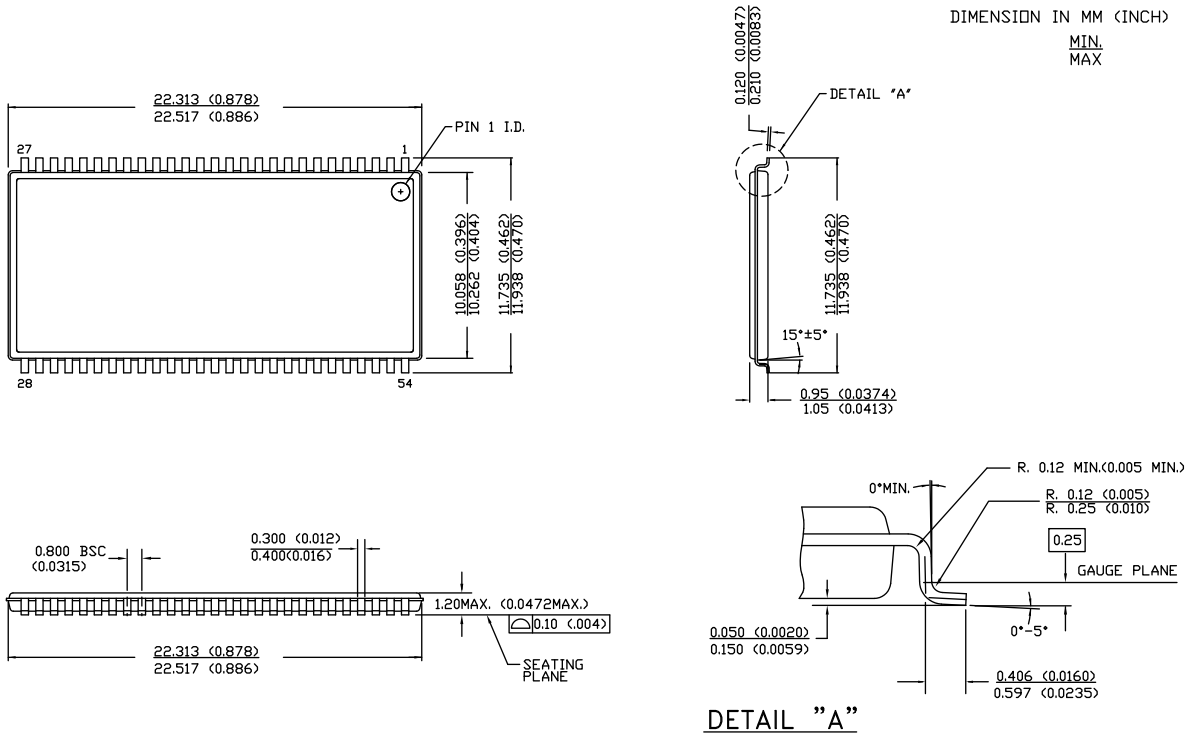

51-85160 \*E

**Package Diagrams** (continued)

**Figure 20. 48-pin SSOP (300 Mils) Package Outline, 51-85061**

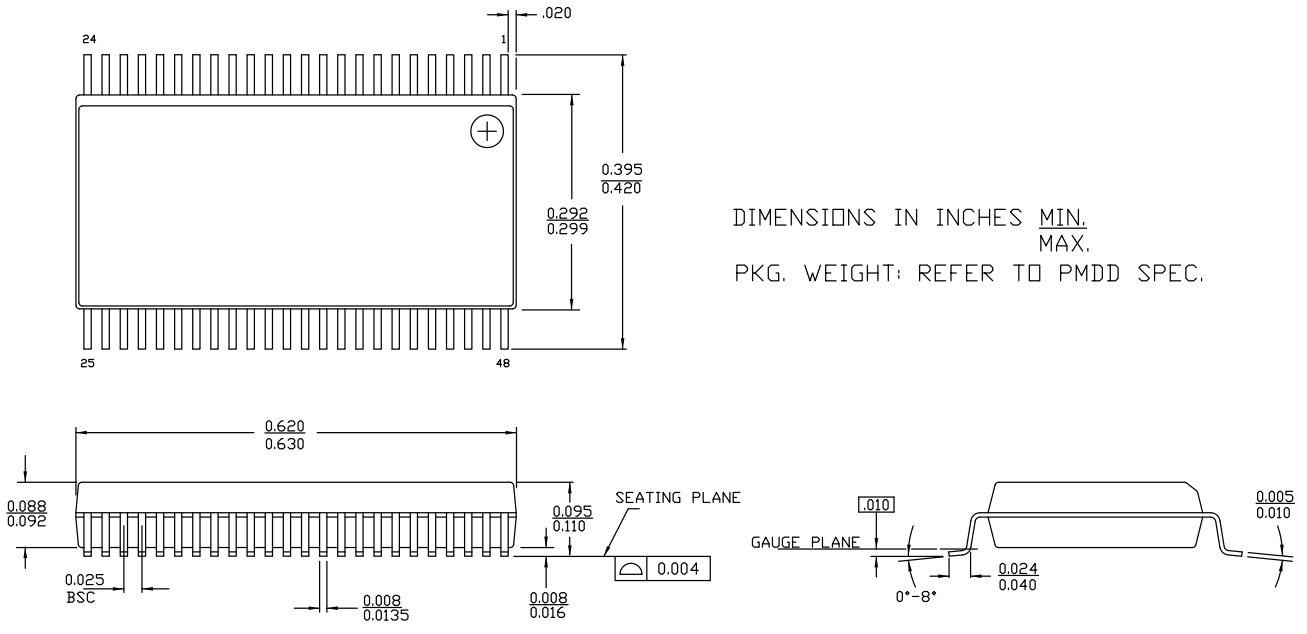

DIMENSIONS IN INCHES MIN.  
MAX.  
 PKG. WEIGHT: REFER TO PMDD SPEC.

51-85061 \*F



## Acronyms

Acronym	Description
BCD	binary coded decimal
$\overline{\text{BHE}}$	byte high enable
$\overline{\text{BLE}}$	byte low enable
$\overline{\text{CE}}$	chip enable
CMOS	complementary metal oxide semiconductor
EIA	electronic industries alliance
$\overline{\text{HSB}}$	hardware store busy
I/O	input/output
nvSRAM	nonvolatile static random access memory
$\overline{\text{OE}}$	output enable
RoHS	restriction of hazardous substances
RWI	read and write inhibited
RTC	real time clock
SRAM	static random access memory
SSOP	shrink small outline package
TSOP	thin small outline package
WE	write enable

## Document Conventions

### Units of Measure

Symbol	Unit of Measure
°C	Degrees Celsius
F	farads
Hz	hertz
kbit	1024 bits
kHz	kilohertz
k $\Omega$	kilohms
MHz	megahertz
$\mu\text{A}$	microamperes
$\mu\text{F}$	microfarads
$\mu\text{s}$	microseconds
mA	milliamperes
ms	milliseconds
ns	nanoseconds
$\Omega$	ohms
%	percent
pF	picofarads
ppm	parts per million
V	volts
W	watts

**Document History Page**

Document Title: CY14B101KA/CY14B101MA, 1-Mbit (128K × 8/64K × 16) nvSRAM with Real Time Clock				
Document Number: 001-42880				
Rev.	ECN No.	Submission Date	Orig. of Change	Description of Change
**	2050747	See ECN	UNC / PYRS	New data sheet.
*A	2607447	11/18/2008	GVCH / AESA	<p>Removed 15 ns access speed, updated "Features", added CY14B101MA (x16) part, changed title to "CY14B101KA/CY14B101MA, 1-Mbit (128K x 8/64K x 16) nvSRAM with Real-Time-Clock".</p> <p>Added 54-pin TSOP II package related information, updated Logic block diagram, added footnote <u>1</u> and <u>2</u>.</p> <p>Pin definition: Updated WE, HSB and NC pin description.</p> <p>Page 4: Updated SRAM READ, SRAM WRITE, Autostore operation description, Page 4: Updated Software store and software recall description</p> <p>Updated Figure 2, Page 4: Updated Hardware store operation and Hardware RECALL (Power up) description</p> <p>Footnote 1 and 10 referenced for Mode selection Table</p> <p>Added footnote 10, updated footnote 8 and 9</p> <p>Page 6: updated Data protection description</p> <p>Page 6: Updated starting and stopping the oscillator description</p> <p>Page 7: Updated Calibrating the clock description</p> <p>Page 8: Added Flags register</p> <p>Updated table 4, added footnote 12 and 13</p> <p>Updated Register map detail Table 5</p> <p>Maximum Ratings: Added Max. Accumulated storage time</p> <p>Changed Output short circuit current parameter name to DC output current</p> <p>Changed <math>I_{CC2}</math> from 6 mA to 10 mA</p> <p>Changed <math>I_{CC3}</math> from 15 mA to 35 mA</p> <p>Changed <math>I_{CC4}</math> from 6 mA to 5 mA</p> <p>Changed <math>I_{SB}</math> from 3 mA to 5 mA</p> <p>Added <math>I_X</math> for HSB</p> <p>Updated <math>I_{CC1}</math>, <math>I_{CC3}</math>, <math>I_{SB}</math> and <math>I_{OZ}</math> Test conditions</p> <p>Changed <math>V_{CAP}</math> voltage min value from 68uF to 61uF</p> <p>Added <math>V_{CAP}</math> voltage max value to 180uF</p> <p>Updated footnote 14 and 15, added footnote 16</p> <p>Added Data retention and Endurance Table</p> <p>Added thermal resistance value to 44/54 TSOP II packages</p> <p>Updated Input Rise and Fall time in AC test Conditions</p> <p>Changed <math>V_{RTCCap\ min}</math> value from 1.2 to 1.5V for industrial Commercial temperature</p> <p>Changed <math>V_{RTCCap\ min}</math> value from 2.7 to 3.6V for industrial Commercial temperature</p> <p>Updated RTC recommended component configuration values</p> <p>Updated <math>t_{OCS}</math> value for minimum and room temperature from 10 and 5sec to 2 and 1sec resp.</p> <p>Referenced footnote 22 to <math>t_{OHA}</math> parameter</p> <p>Updated All switching waveforms</p> <p>Updated footnote 22, added footnote 25</p> <p>Added Figure 11 (SRAM WRITE CYCLE: <math>\overline{BHE}</math> and <math>\overline{BLE}</math> controlled)</p> <p>Changed <math>t_{STORE}</math> max value from 15ms to 8ms</p> <p>Updated <math>t_{DELAY}</math> value</p> <p>Added <math>V_{HDIS}</math>, <math>t_{HHHD}</math> and <math>t_{LZHSB}</math> parameters</p> <p>Updated footnote 29, added footnote 31 and 32</p> <p>Software controlled STORE/RECALL Table: Changed <math>t_{AS}</math> to <math>t_{SA}</math></p> <p>Changed <math>t_{GHAX}</math> to <math>t_{HA}</math>, changed <math>t_{HA}</math> value from 1ns to 0ns</p> <p>Added Figure 14</p> <p>Added <math>t_{DHSB}</math> parameter, changed <math>t_{HLHX}</math> to <math>t_{PHSB}</math></p> <p>Updated <math>t_{SS}</math> from 70 us to 100 us, added truth table for SRAM operations</p>

**Document History Page** (continued)

Document Title: CY14B101KA/CY14B101MA, 1-Mbit (128K × 8/64K × 16) nvSRAM with Real Time Clock				
Document Number: 001-42880				
Rev.	ECN No.	Submission Date	Orig. of Change	Description of Change
*A (cont.)	2607447	11/18/2008	GVCH / AESA	Updated ordering information and part numbering nomenclature
*B	2654484	02/05/09	GVCH / PYRS	Changed the data sheet from Advance information to Preliminary Changed X <sub>1</sub> , X <sub>2</sub> pin names to X <sub>out</sub> , X <sub>in</sub> respectively Updated Real Time Clock operation description Added footnotes 11 and 12 Added default values to RTC Register Map" table 3 Updated flag register description in Register Map Detail" table 4 Changed C1, C2 values to 21pF, 21pF respectively Changed I <sub>BAK</sub> value from 350 nA to 450 nA at hot temperature Changed V <sub>RTCcap</sub> typical value from 2.4V to 3.0V Referenced Note 15 to parameters t <sub>LZCE</sub> , t <sub>HZCE</sub> , t <sub>LZOE</sub> , t <sub>HZOE</sub> , t <sub>LZBE</sub> , t <sub>LZWE</sub> , t <sub>HZWE</sub> and t <sub>HZBE</sub> Added footnote 24 Updated Figure 13
*C	2733909	07/09/09	GVCH / AESA	Page 3; Added note to AutoStore Operation description Page 4; Updated Hardware STORE (HSB) Operation description Page 4; Updated Software STORE Operation description Added best practices Changed C1, C2 values to 10pF, 67pF respectively Changed I <sub>BAK</sub> and V <sub>RTCcap</sub> parameter values Added R <sub>BKCHG</sub> parameter Updated V <sub>HDIS</sub> parameter description Updated t <sub>DELAY</sub> parameter description Updated footnote 28 and added footnote 35
*D	2757375	08/28/09	GVCH	Moved data sheet status from Preliminary to Final Removed commercial temperature related specs Removed 20ns access speed related specs Updated Thermal resistance values for all the packages Changed V <sub>RTCbat</sub> max value from 3.3V to 3.6V Changed R <sub>BKCHG</sub> min value from 450Ω to 350Ω Updated footnote 18
*E	2767333	01/06/10	GVCH / PYRS	Changed STORE cycles to QuantumTrap from 200K to 1 Million Added Data Retention and Endurance table Updated I <sub>BAK</sub> RTC backup current spec unit from nA to μA Added <a href="#">Contents</a> .
*F	2899937	03/26/10	GVCH	Added more clarity on <a href="#">HSB pin operation</a> <a href="#">Table 1</a> : Added more clarity on BHE/BLE pin operation Updated HSB pin operation in <a href="#">Switching Waveforms</a> Updated footnote 30 Updated <a href="#">Ordering Information</a> table. Updated package diagrams. Updated copyright section.
*G	3134300	01/11/2011	GVCH	Updated <a href="#">Setting the Clock</a> description Added footnote 15 Updated 'W' bit description in <a href="#">Register Map Detail</a> table Updated best practices Updated input capacitance for <a href="#">BHE</a> and <a href="#">BLE</a> pin Updated input and output capacitance for HSB pin Added t <sub>RTCp</sub> parameter to <a href="#">RTC Characteristics</a> table <a href="#">Figure 13</a> : Typo error fixed Added <a href="#">Acronyms</a> and <a href="#">Document Conventions</a> .

**Document History Page** (continued)

Document Title: CY14B101KA/CY14B101MA, 1-Mbit (128K × 8/64K × 16) nvSRAM with Real Time Clock				
Document Number: 001-42880				
Rev.	ECN No.	Submission Date	Orig. of Change	Description of Change
*H	3150308	01/21/2011	GVCH	No technical updates.
*I	3313245	07/14/2011	GVCH	Updated <a href="#">DC Electrical Characteristics</a> (Added Note 19 and referred the same note in V <sub>CAP</sub> parameter). Updated <a href="#">AC Switching Characteristics</a> (Added Note 26 and referred the same note in Parameters).
*J	3500268	01/18/2012	GVCH	Added footnote 8 and 12.
*K	3659138	08/14/2012	GVCH	Updated <a href="#">Real Time Clock Operation</a> (description). Updated <a href="#">Maximum Ratings</a> (Changed “Ambient temperature with power applied” to “Maximum junction temperature”). Updated <a href="#">DC Electrical Characteristics</a> (Added V <sub>V<sub>CAP</sub></sub> parameter and its details, added Note 21 and referred the same note in V <sub>V<sub>CAP</sub></sub> parameter, also referred Note 22 in V <sub>V<sub>CAP</sub></sub> parameter). Updated <a href="#">Package Diagrams</a> (spec 51-85160 (Changed revision from *C to *D)).
*L	4047965	07/03/2013	GVCH	Updated <a href="#">Pin Definitions</a> : Updated HSB pin description (Added more clarity). Updated <a href="#">Device Operation</a> : Updated <a href="#">AutoStore Operation</a> (Removed sentence “The $\overline{\text{HSB}}$ signal is monitored by the system to detect if an AutoStore cycle is in progress.”). Updated <a href="#">Real Time Clock Operation</a> : Updated <a href="#">Backup Power</a> (Added Note). Added <a href="#">RTC External Components</a> . Moved <a href="#">Figure 5</a> from <a href="#">Flags Register</a> section to <a href="#">RTC External Components</a> section. Added <a href="#">PCB Design Considerations for RTC</a> . Updated <a href="#">Package Diagrams</a> : spec 51-85087 – Changed revision from *D to *E. spec 51-85061 – Changed revision from *E to *F. Updated to new template.
*M	4563189	11/06/2014	GVCH	Updated <a href="#">Functional Description</a> : Added “For a complete list of related documentation, click <a href="#">here</a> .” at the end. Updated <a href="#">Package Diagrams</a> : Spec 51-85160 - Changed revision from *D to *E
*N	4666625	02/20/2015	GVCH	No technical updates. Completing Sunset Review.
*O	5146824	02/22/2016	GVCH	Updated <a href="#">Package Diagrams</a> : Fixed typo in <a href="#">Figure 20</a> (Updated with correct diagram for spec 51-85061 *F). Updated to new template.
*P	5985517	12/06/2017	AESATMP8	Updated logo and Copyright.

## Sales, Solutions, and Legal Information

### Worldwide Sales and Design Support

Cypress maintains a worldwide network of offices, solution centers, manufacturer's representatives, and distributors. To find the office closest to you, visit us at [Cypress Locations](#).

#### Products

ARM® Cortex® Microcontrollers	<a href="http://cypress.com/arm">cypress.com/arm</a>
Automotive	<a href="http://cypress.com/automotive">cypress.com/automotive</a>
Clocks & Buffers	<a href="http://cypress.com/clocks">cypress.com/clocks</a>
Interface	<a href="http://cypress.com/interface">cypress.com/interface</a>
Internet of Things	<a href="http://cypress.com/iot">cypress.com/iot</a>
Memory	<a href="http://cypress.com/memory">cypress.com/memory</a>
Microcontrollers	<a href="http://cypress.com/mcu">cypress.com/mcu</a>
PSoC	<a href="http://cypress.com/psoc">cypress.com/psoc</a>
Power Management ICs	<a href="http://cypress.com/pmic">cypress.com/pmic</a>
Touch Sensing	<a href="http://cypress.com/touch">cypress.com/touch</a>
USB Controllers	<a href="http://cypress.com/usb">cypress.com/usb</a>
Wireless Connectivity	<a href="http://cypress.com/wireless">cypress.com/wireless</a>

#### PSoC® Solutions

[PSoC 1](#) | [PSoC 3](#) | [PSoC 4](#) | [PSoC 5LP](#) | [PSoC 6](#)

#### Cypress Developer Community

[Forums](#) | [WICED IOT Forums](#) | [Projects](#) | [Video](#) | [Blogs](#) | [Training](#) | [Components](#)

#### Technical Support

[cypress.com/support](http://cypress.com/support)

---

© Cypress Semiconductor Corporation, 2008-2017. This document is the property of Cypress Semiconductor Corporation and its subsidiaries, including Spansion LLC ("Cypress"). This document, including any software or firmware included or referenced in this document ("Software"), is owned by Cypress under the intellectual property laws and treaties of the United States and other countries worldwide. Cypress reserves all rights under such laws and treaties and does not, except as specifically stated in this paragraph, grant any license under its patents, copyrights, trademarks, or other intellectual property rights. If the Software is not accompanied by a license agreement and you do not otherwise have a written agreement with Cypress governing the use of the Software, then Cypress hereby grants you a personal, non-exclusive, nontransferable license (without the right to sublicense) (1) under its copyright rights in the Software (a) for Software provided in source code form, to modify and reproduce the Software solely for use with Cypress hardware products, only internally within your organization, and (b) to distribute the Software in binary code form externally to end users (either directly or indirectly through resellers and distributors), solely for use on Cypress hardware product units, and (2) under those claims of Cypress's patents that are infringed by the Software (as provided by Cypress, unmodified) to make, use, distribute, and import the Software solely for use with Cypress hardware products. Any other use, reproduction, modification, translation, or compilation of the Software is prohibited.

TO THE EXTENT PERMITTED BY APPLICABLE LAW, CYPRESS MAKES NO WARRANTY OF ANY KIND, EXPRESS OR IMPLIED, WITH REGARD TO THIS DOCUMENT OR ANY SOFTWARE OR ACCOMPANYING HARDWARE, INCLUDING, BUT NOT LIMITED TO, THE IMPLIED WARRANTIES OF MERCHANTABILITY AND FITNESS FOR A PARTICULAR PURPOSE. To the extent permitted by applicable law, Cypress reserves the right to make changes to this document without further notice. Cypress does not assume any liability arising out of the application or use of any product or circuit described in this document. Any information provided in this document, including any sample design information or programming code, is provided only for reference purposes. It is the responsibility of the user of this document to properly design, program, and test the functionality and safety of any application made of this information and any resulting product. Cypress products are not designed, intended, or authorized for use as critical components in systems designed or intended for the operation of weapons, weapons systems, nuclear installations, life-support devices or systems, other medical devices or systems (including resuscitation equipment and surgical implants), pollution control or hazardous substances management, or other uses where the failure of the device or system could cause personal injury, death, or property damage ("Unintended Uses"). A critical component is any component of a device or system whose failure to perform can be reasonably expected to cause the failure of the device or system, or to affect its safety or effectiveness. Cypress is not liable, in whole or in part, and you shall and hereby do release Cypress from any claim, damage, or other liability arising from or related to all Unintended Uses of Cypress products. You shall indemnify and hold Cypress harmless from and against all claims, costs, damages, and other liabilities, including claims for personal injury or death, arising from or related to any Unintended Uses of Cypress products.

Cypress, the Cypress logo, Spansion, the Spansion logo, and combinations thereof, WICED, PSoC, CapSense, EZ-USB, F-RAM, and Traveo are trademarks or registered trademarks of Cypress in the United States and other countries. For a more complete list of Cypress trademarks, visit [cypress.com](http://cypress.com). Other names and brands may be claimed as property of their respective owners.