

APPROVED: _____
 DATE: _____ TITLE: _____

Rev	AWO #	Description	Date	Appr
-		RELEASED	5/21/12	
A		UPDATED DRAWING	11/1/16	HR/AT

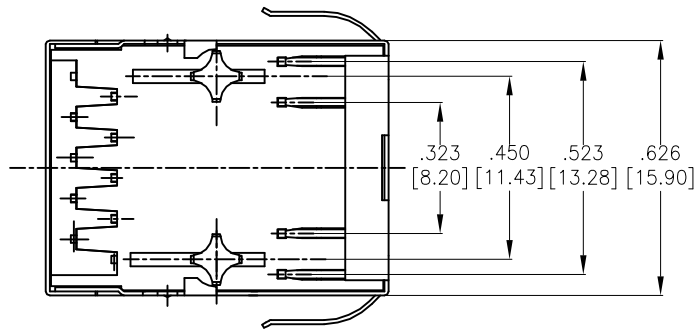
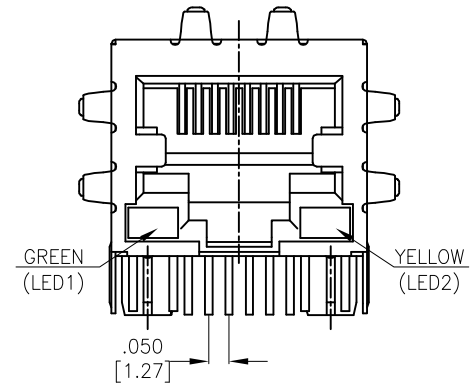
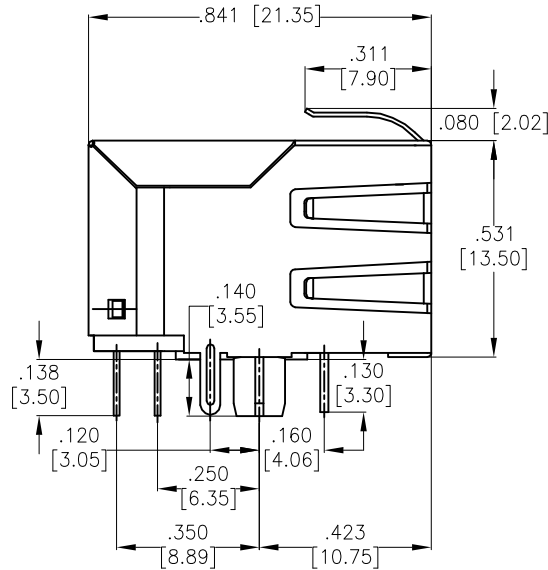
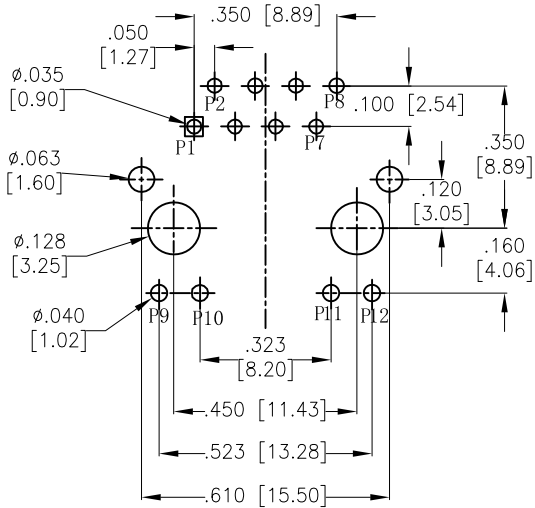

X	PLATING
0	15 µin Gold
1	30 µin Gold
2	50 µin Gold
6	6 µin Gold

SPECIFICATIONS:
 Material:
 Insulator: Thermoplastic, rated UL 94V-0
 Insulator color: Black
 Contacts: Copper Alloy
 Shield: Copper Alloy, Nickel plated
 Plating:
 Round contact
 Gold over Nickel underplate overall
 Flat contact
 Gold over Nickel underplate on contact area,
 Tin over Nickel underplate on solder tails
 (See chart for thickness)
 Electrical:
 Voltage rating: 150 VAC
 Contact resistance: 20 mohms max
 Insulation resistance: 500 Mohms min
 Dielectric withstanding voltage: 1500VAC or 2250VDC
 Temperature Rating:
 Operating temperature: 0°C to +70°C
 Environmental:
 Lead free, RoHS compliant.



UNLESS OTHERWISE SPECIFIED
 ALL DIMENSIONS ARE INCHES [MM]
 TOLERANCES: EXCEPT AS NOTED
 INCHES HOLES

.X ± .10	∅X ± .10
.XX ± .020	∅XX ± .015
.XXX ± .015	∅XXX ± .010

APPROVALS		DATE
DRAWN	AY	5/21/12
CHECKED	AC	5/21/12
APPROVED		

ADAM TECH
 909 Rahway Avenue, Union, NJ 07083
 Phone: 908-687-5000 Fax: 908-687-5710

TITLE: MODULAR JACK GANGED, 1 PORT, 8P8C
 W/ LED1 GREEN, LED 2 YELLOW

SIZE	PART NO.	REV.
X	MTJ-88TX1-FSD-PG-LH-M4	A

REF: S00005C SCALE: NTS SHEET 1 OF 2

6

5

4

3

2

1

APPROVED: _____

DATE: _____ TITLE: _____

Rev	AWO #	Description	Date	Apr
-----	-------	-------------	------	-----

SEE SHT 1 OF 2 FOR REVISION

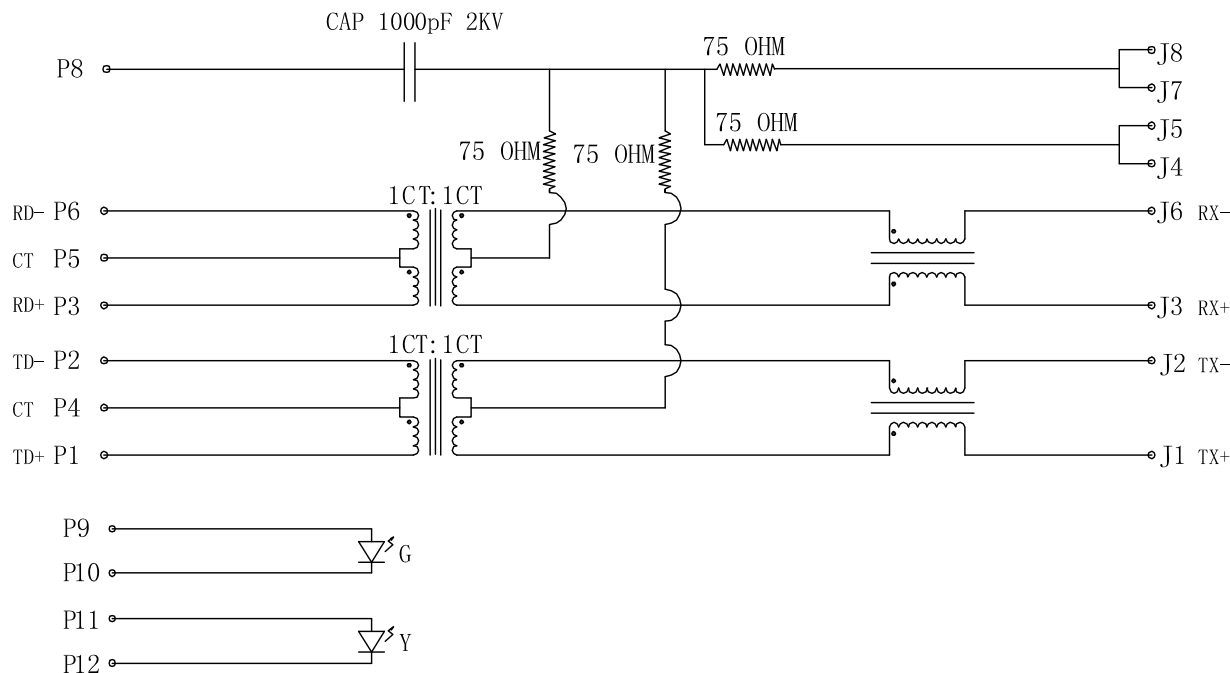

ELECTRICAL SPECIFICATIONS:

- Turns Ratio: (P1 ~ P2) : (J1 ~ J2) 1:1 ±3%
(P3 ~ P6) : (J3 ~ J6) 1:1 ±3%
- Inductance: (P1 ~ P2) and (P3 ~ P6) 350uH min. @ 0.1V, 100KHZ, 8mA DC Bias
- Leakage Inductance: P1 ~ P2 (with J1 and J2 Short): 0.35uH Max @ 1 MHZ
P3 ~ P6 (with J3 and J6 Short): 0.35uH Max @ 1 MHZ
- Interwinding Capacitance: (P1 ~ P2) : (J1 ~ J2): 35pF Max. @ 1MHZ
(P3 ~ P6) : (J3 ~ J6): 35pF Max @ 1MHZ
- DC Resistance:(J1 ~ J2):(J3 ~ J6) :1.2 Ohms Max
- Return Loss: 1MHZ to 30MHZ: -18dB Min
30MHZ to 60MHZ: -(18-20log(f/30))dB Min (whrer f is in MHZ)
60MHZ to 80MHZ: -12dB Min
- Dielectric Withstanding: (P1~P2) : (J1~J2) : 1500VAC or 2250VDC
(P3~P6) : (J3~J6) : 1500VAC or 2250VDC
- Insertion Loss: 1MHZ TO 100MHZ : -1.2dB Max
- Cross Talk: 1MHZ to 100MHZ: -30dB Min
- Common to Common mode Attenuation 1MHZ to 100MHZ: -30dB Min

UNLESS OTHERWISE SPECIFIED
ALL DIMENSIONS ARE INCHES [MM]
TOLERANCES: EXCEPT AS NOTED
INCHES HOLES

.X ± .10	Ø.X ± .10
.XX ± .020	Ø.XX ± .015
.XXX ± .015	Ø.XXX ± .010

ADAM TECH

909 Rahway Avenue, Union, NJ 07083
Phone: 908-687-5000 Fax: 908-687-5710

TITLE: MODULAR JACK GANGED, 1 PORT, 8P8C
W/ LED1 GREEN, LED 2 YELLOW

APPROVALS		DATE
DRAWN	AY	5/21/12
CHECKED	AC	5/21/12
APPROVED		

SIZE	PART NO.	REV.
X	MTJ-88TX1-FSD-PG-LH-M4	A
REF: S00005C	SCALE: NTS	SHEET 2 OF 2

6

5

4

3

2

1