

35 W wide input range flyback converter using HVLED001A quasi resonant flyback controller and STF10LN80K5

Data brief



Features

- Input voltage: V_{in} : 90 - 305 Vrms, f: 45 - 66 Hz
- Output voltage: 48 V / 730 mA
- High power factor, low THD
- No-load: better than 250 mW @ 230 V_{in}
- Full load efficiency: 90%
- Short circuit protection with auto restart
- Safety: accordance with EN60065
- PCB board: 130 mm x 50 mm single side PCB
- RoHS compliant

Description

The STEVAL-ILL069V2 supplies a stable and insulated 48 V voltage bus suitable for secondary side circuitry (e.g., LED current generators) for a total output power of 35 W when a wide range of input voltages is applied at its input. An auxiliary 16 V output is also present to supply small circuits which absorb a maximum current of 20 mA.

A very high power factor is obtained thanks to the features of the HVLED001A. Input voltage variations, excessive input voltage (surge or burst overvoltage) or very low input voltages are managed by some of the protections of the HVLED001A, improving the reliability of the application.

The efficiency of the application is very high even at very low load thanks to the improved frequency fold-back feature that also reduces the output voltage ripple at light load.

Output short circuit and overload protections are auto-restart for safe operation in lighting environments.

1 Board description

Figure 1: Jumper and connector locations

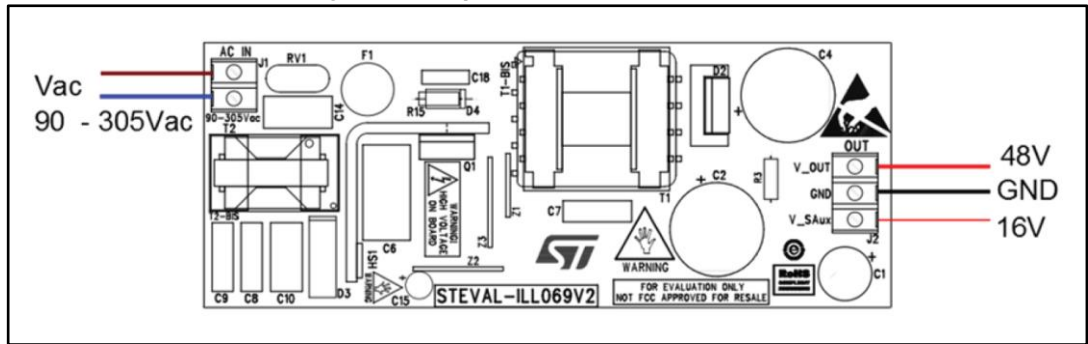

2 Schematic diagram

Figure 2: STEVAL-ILL069V2 circuit schematic

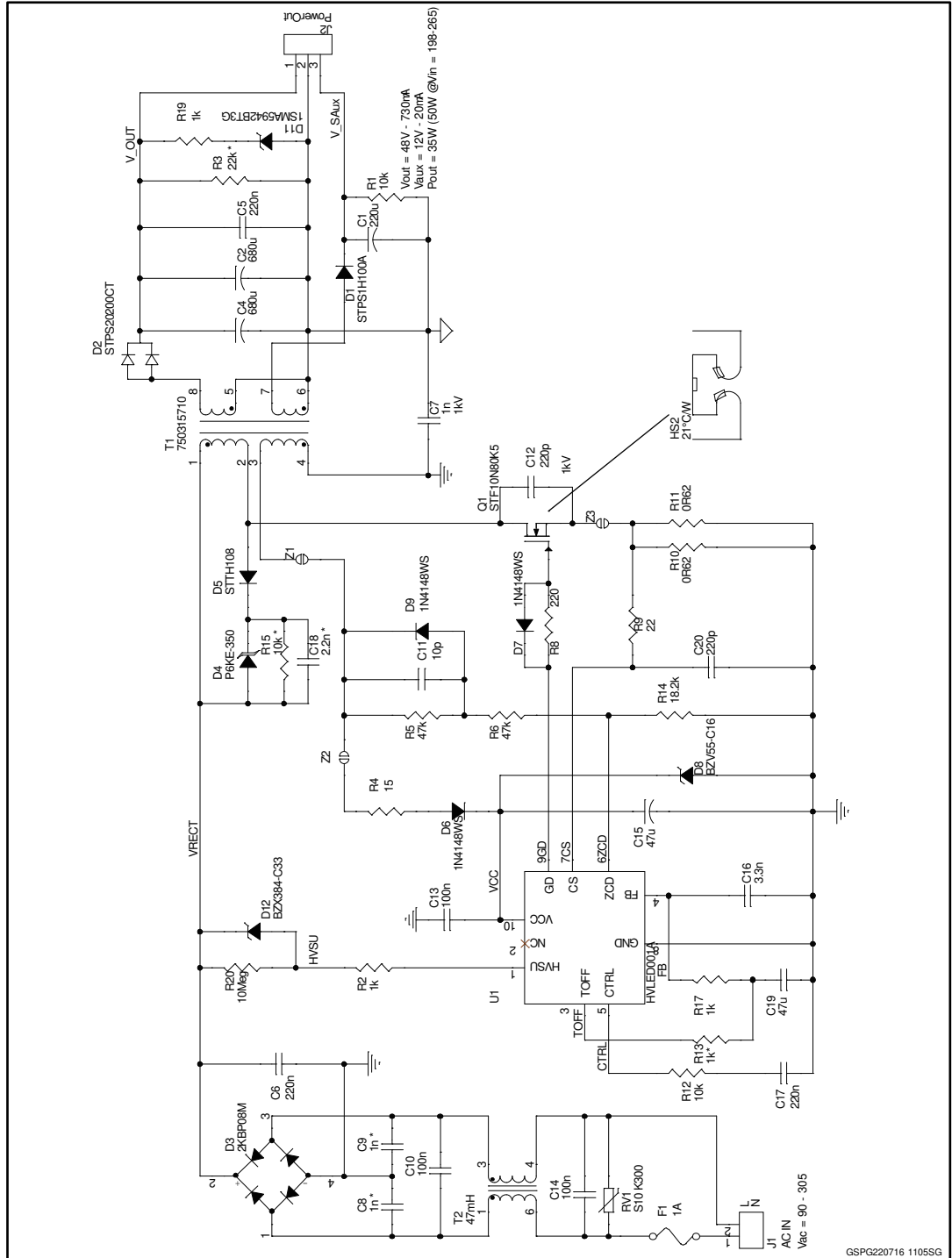

3 Revision history

Table 1: Document revision history

Date	Version	Changes
15-Sep-2016	1	Initial release.

IMPORTANT NOTICE – PLEASE READ CAREFULLY

STMicroelectronics NV and its subsidiaries ("ST") reserve the right to make changes, corrections, enhancements, modifications, and improvements to ST products and/or to this document at any time without notice. Purchasers should obtain the latest relevant information on ST products before placing orders. ST products are sold pursuant to ST's terms and conditions of sale in place at the time of order acknowledgement.

Purchasers are solely responsible for the choice, selection, and use of ST products and ST assumes no liability for application assistance or the design of Purchasers' products.

No license, express or implied, to any intellectual property right is granted by ST herein.

Resale of ST products with provisions different from the information set forth herein shall void any warranty granted by ST for such product.

ST and the ST logo are trademarks of ST. All other product or service names are the property of their respective owners.

Information in this document supersedes and replaces information previously supplied in any prior versions of this document.

© 2016 STMicroelectronics – All rights reserved