

60294-2 ✓ ACTIVE

FASTIN-FASTON | FASTIN-FASTON 250

TE Internal #: 60294-2

Quick Disconnects, Tab, 22 – 18 AWG Wire Size, .32 – .82 mm<sup>2</sup> Wire Size, Mating Tab Width 6.35 mm [.25 in], Straight, Brass, FASTIN-FASTON 250

[View on TE.com >](#)



Terminals & Splices > Quick Disconnects

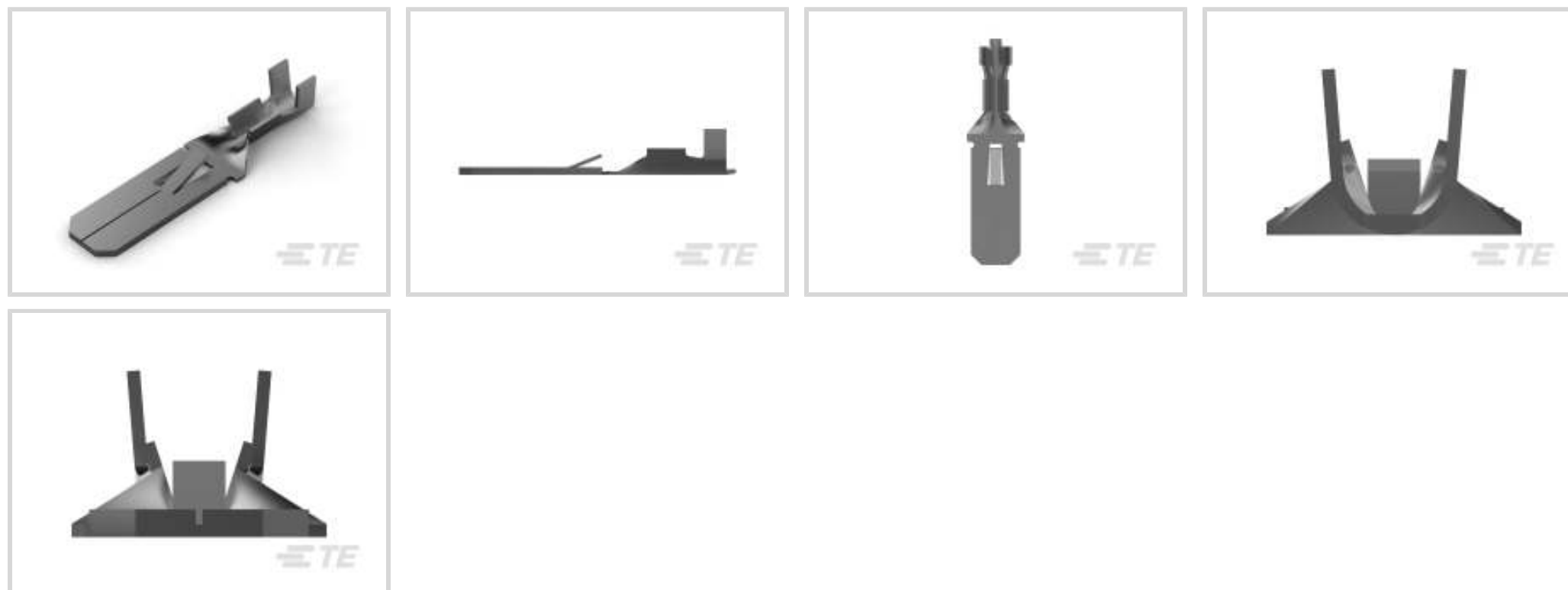

Quick Disconnect Terminal Type: **Tab**

Wire Size: **.32 – .82 mm<sup>2</sup>**

Mating Tab Width: **6.35 mm [.25 in]**

Mating Tab Thickness: **.81 mm [.032 in]**

## Features

### Product Type Features

|                 |        |
|-----------------|--------|
| Insertion Force | Normal |
|-----------------|--------|

### Configuration Features

|                     |        |
|---------------------|--------|
| Connection Capacity | Single |
|---------------------|--------|

|                                   |               |
|-----------------------------------|---------------|
| Compatible With Wire & Cable Type | Discrete Wire |
|-----------------------------------|---------------|

### Contact Features

|                                |     |
|--------------------------------|-----|
| Quick Disconnect Terminal Type | Tab |
|--------------------------------|-----|

|                  |                  |
|------------------|------------------|
| Mating Tab Width | 6.35 mm [.25 in] |
|------------------|------------------|

|                      |                  |
|----------------------|------------------|
| Mating Tab Thickness | .81 mm [.032 in] |
|----------------------|------------------|

|                      |          |
|----------------------|----------|
| Terminal Orientation | Straight |
|----------------------|----------|

|                       |       |
|-----------------------|-------|
| Contact Base Material | Brass |
|-----------------------|-------|

|                           |     |
|---------------------------|-----|
| Terminal Plating Material | Tin |
|---------------------------|-----|

|            |         |
|------------|---------|
| Crimp Type | F-Crimp |
|------------|---------|

|             |      |
|-------------|------|
| Barrel Type | Open |
|-------------|------|

### Termination Features



|                       |              |
|-----------------------|--------------|
| Product Terminates To | Wire & Cable |
|-----------------------|--------------|

### Mechanical Attachment

|  |         |
|--|---------|
|  | .055 in |
|--|---------|

|                         |      |
|-------------------------|------|
| Wire Insulation Support | With |
|-------------------------|------|

|                       |               |
|-----------------------|---------------|
| Mating Retention Type | Locking Lance |
|-----------------------|---------------|

### Dimensions

|                             |                 |
|-----------------------------|-----------------|
| Terminal Material Thickness | .4 mm [.015 in] |
|-----------------------------|-----------------|

|                |                     |
|----------------|---------------------|
| Product Length | 28.12 mm [1.107 in] |
|----------------|---------------------|

|                                      |                             |
|--------------------------------------|-----------------------------|
| Compatible Insulation Diameter Range | 2.2 – 3 mm [.086 – .118 in] |
|--------------------------------------|-----------------------------|

|           |                           |
|-----------|---------------------------|
| Wire Size | .32 – .82 mm <sup>2</sup> |
|-----------|---------------------------|

### Usage Conditions

|                   |             |
|-------------------|-------------|
| Insulation Option | Uninsulated |
|-------------------|-------------|

|                             |                             |
|-----------------------------|-----------------------------|
| Operating Temperature Range | -40 – 110 °C [-40 – 230 °F] |
|-----------------------------|-----------------------------|

### Packaging Features

|                    |      |
|--------------------|------|
| Packaging Quantity | 9000 |
|--------------------|------|

|                  |            |
|------------------|------------|
| Packaging Method | Strip/Reel |
|------------------|------------|

### Other

|                             |  |
|-----------------------------|--|
| Terminals & Splices Comment | "According to DIN, except Wire Size Range", Without Locking Hole |
|-----------------------------|--|

## Product Compliance

[For compliance documentation, visit the product page on TE.com>](#)

|                              |           |
|------------------------------|-----------|
| EU RoHS Directive 2011/65/EU | Compliant |
|------------------------------|-----------|

|                             |           |
|-----------------------------|-----------|
| EU ELV Directive 2000/53/EC | Compliant |
|-----------------------------|-----------|

|   |   |
|---|---|
| China RoHS 2 Directive MIIT Order No 32, 2016 | No Restricted Materials Above Threshold |
|---|---|

|  |   |
|--|---|
| EU REACH Regulation (EC) No. 1907/2006 | Current ECHA Candidate List: JUNE 2023 (235)<br>Candidate List Declared Against: JUNE 2023 (235)<br>Does not contain REACH SVHC |
|--|---|

|                 |   |
|-----------------|---|
| Halogen Content | Low Halogen - Br, Cl, F, I < 900 ppm per homogenous material. Also BFR/CFR/PVC Free |
|-----------------|---|

|                           |  |
|---------------------------|--|
| Solder Process Capability | Not applicable for solder process capability |
|---------------------------|--|

## Product Compliance Disclaimer

This information is provided based on reasonable inquiry of our suppliers and represents our current actual knowledge based on the information they provided. This information is subject to change. The part numbers that TE has identified as EU RoHS compliant have a maximum concentration of 0.1% by weight in homogenous materials for lead, hexavalent chromium, mercury, PBB, PBDE, DBP, BBP, DEHP, DIBP, and 0.01% for cadmium, or qualify for an exemption to these limits as defined in the Annexes of Directive 2011/65/EU (RoHS2). Finished electrical and electronic equipment products will be CE marked as required by Directive 2011/65/EU. Components may not be CE marked. Additionally, the part numbers that TE has identified as EU ELV compliant have a maximum concentration of 0.1% by weight in homogenous materials for lead, hexavalent chromium, and mercury, and 0.01% for cadmium, or qualify for an exemption to these limits as defined in the Annexes of Directive 2000/53/EC (ELV). Regarding the REACH Regulation, the information TE provides on SVHC in articles for this part number is based on the latest European Chemicals Agency (ECHA) 'Guidance on requirements for substances in articles' posted at this URL: <https://echa.europa.eu/guidance-documents/guidance-on-reach>

## Compatible Parts

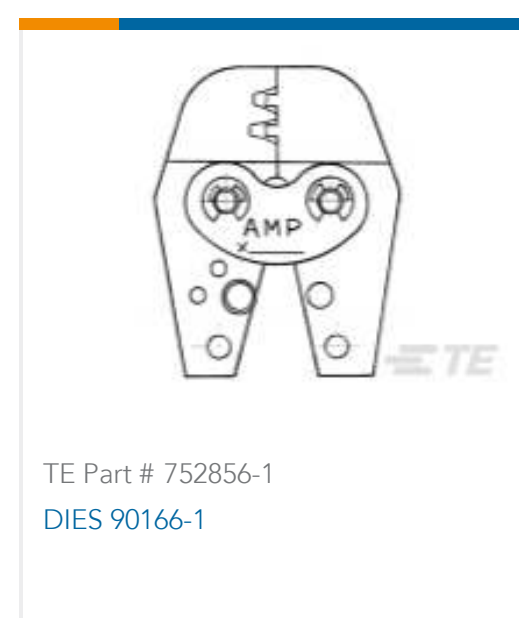

## Also in the Series | FASTIN-FASTON 250

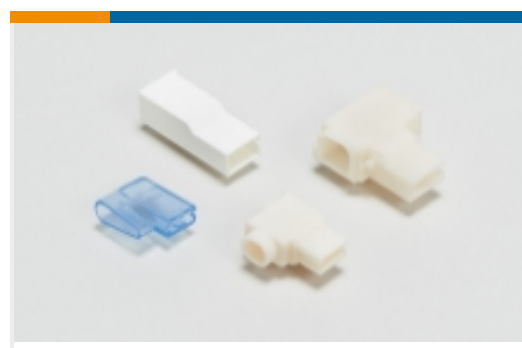

Crimp Terminal Housings(211)



Insertion &amp; Extraction Tools(2)



PCB Terminals(2)

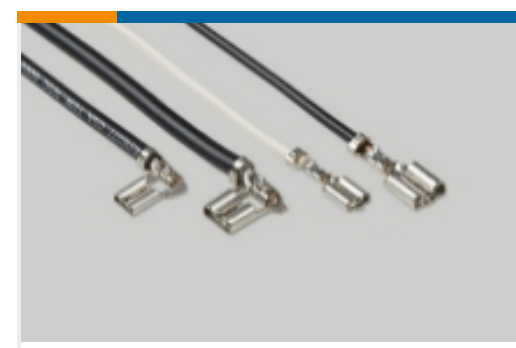

Quick Disconnects(254)

## Customers Also Bought

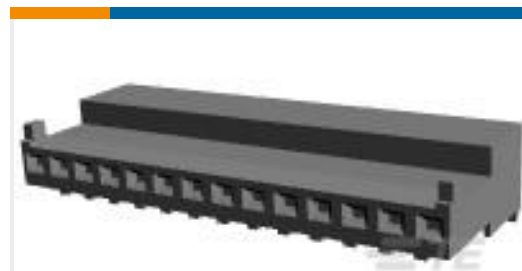
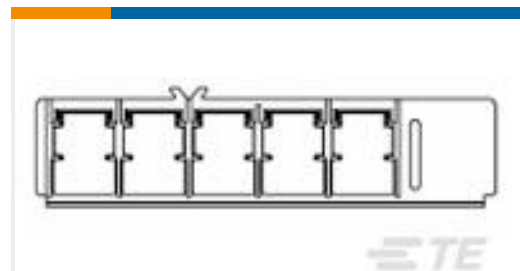
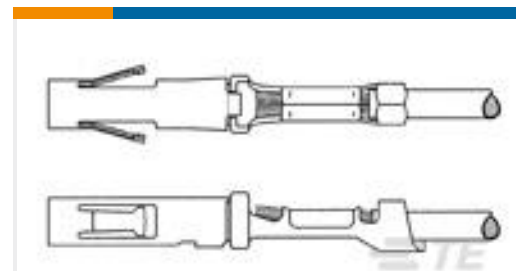
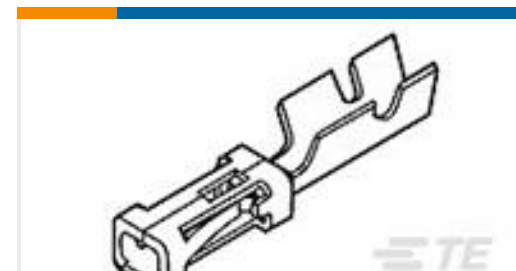
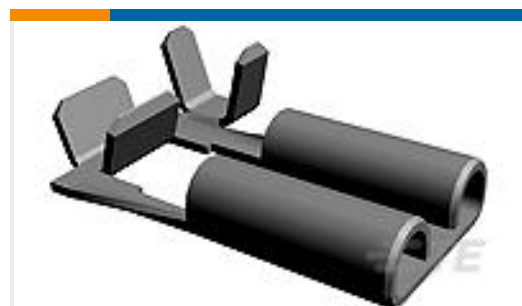
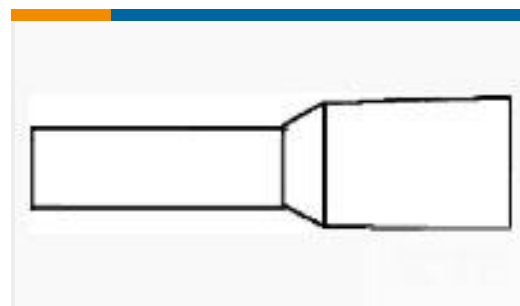
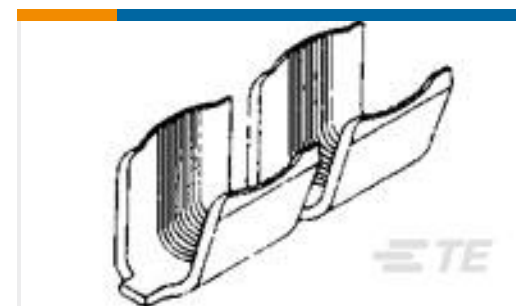
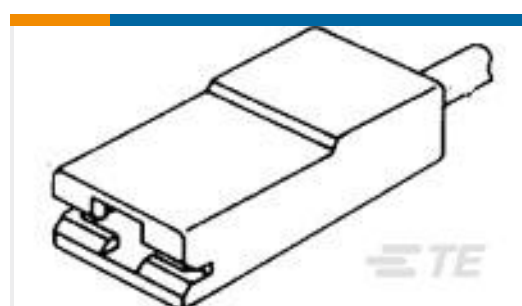
TE Part #4-643814-4  
14P MTA100 CONN ASSY POL RIBTE Part #5787590-1  
BATT INT,INSERT ASSY,5P,7.2VTE Part #164153-6  
CONTACT, SOCKET, CRIMP, TYPE XITE Part #167301-4  
MOD-4 REC.CONT.SCPTE Part #1742086-2  
187 FASTON,FLAG,REC.,18-22 AWG,  
TPBRTE Part #2-966292-7  
FER,WIRE,PL SLV,6.00/10,L12,GREEN,  
LPTE Part #9-1879336-1  
CPF 0603 2K0 1% 50PPM 1K RLTE Part #280002-1  
AMPLIVAR SPLICETE Part #735052  
110 FASTON SLEEVE REC. 1P  
NATURAL

## Documents

### Product Drawings

[FF 250 TAB 22-18 AWG .032 TPBR](#)

English

### CAD Files

[3D PDF](#)

3D

### Customer View Model

[ENG\\_CVM\\_CVM\\_60294-2\\_CS\\_c-60294-2-cs.2d\\_dxf.zip](#)



English

**Customer View Model**

[ENG\\_CVM\\_CVM\\_60294-2\\_CS\\_c-60294-2-cs.3d\\_igs.zip](#)

English

**Customer View Model**

[ENG\\_CVM\\_CVM\\_60294-2\\_CS\\_c-60294-2-cs.3d\\_stp.zip](#)

English

By downloading the CAD file I accept and agree to the [Terms and Conditions](#) of use.

---

**Datasheets & Catalog Pages**

[1654742\\_HOUSEHOLD\\_APPLIANCES\\_RAST5](#)

English

---

**Product Specifications**

[Application Specification](#)

English

---

**Product Environmental Compliance**

[Product Compliance](#)

English

[Product Compliance](#)

English

---

**Agency Approvals**

[Agency Approval Document](#)

English