

REVISIONS				
P	LTN	DESCRIPTION	DATE	APVD
0		RELEASED PER 03GB-0152-02	18MAR02	KW SR
A		RELEASED PER ECR-21-117154	02AUG2022	SM VS

- PARTS COMPLY TO AMP SOLDERABILITY SPECIFICATION 109-11-3.
- CIRCUIT IDENTIFICATION CHARACTERS ARE ADJACENT TO THE INDICATED CAVITIES, BUT LOCATION AND ORIENTATION MAY DIFFER FROM PRINT.
- DIMENSIONS IN BRACKETS ARE IN INCHES.
- DIMENSIONS SHOWN REPRESENT PRODUCT IN DRY CONDITION. ADDITIONAL 2% GROWTH DUE TO END USE LOCATION MOISTURE ABSORPTION MAY OCCUR AND SHOULD BE ACCOUNTED FOR.

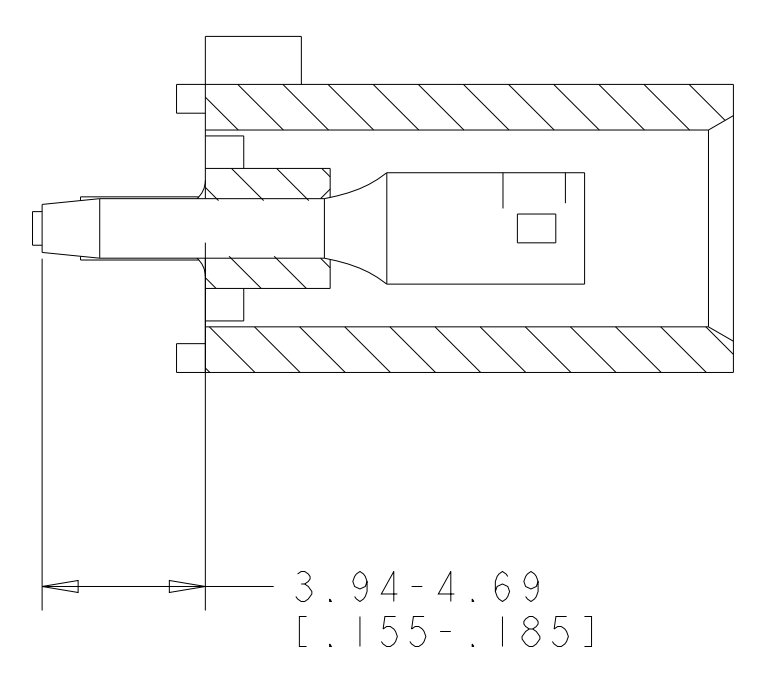

SECTION A-A

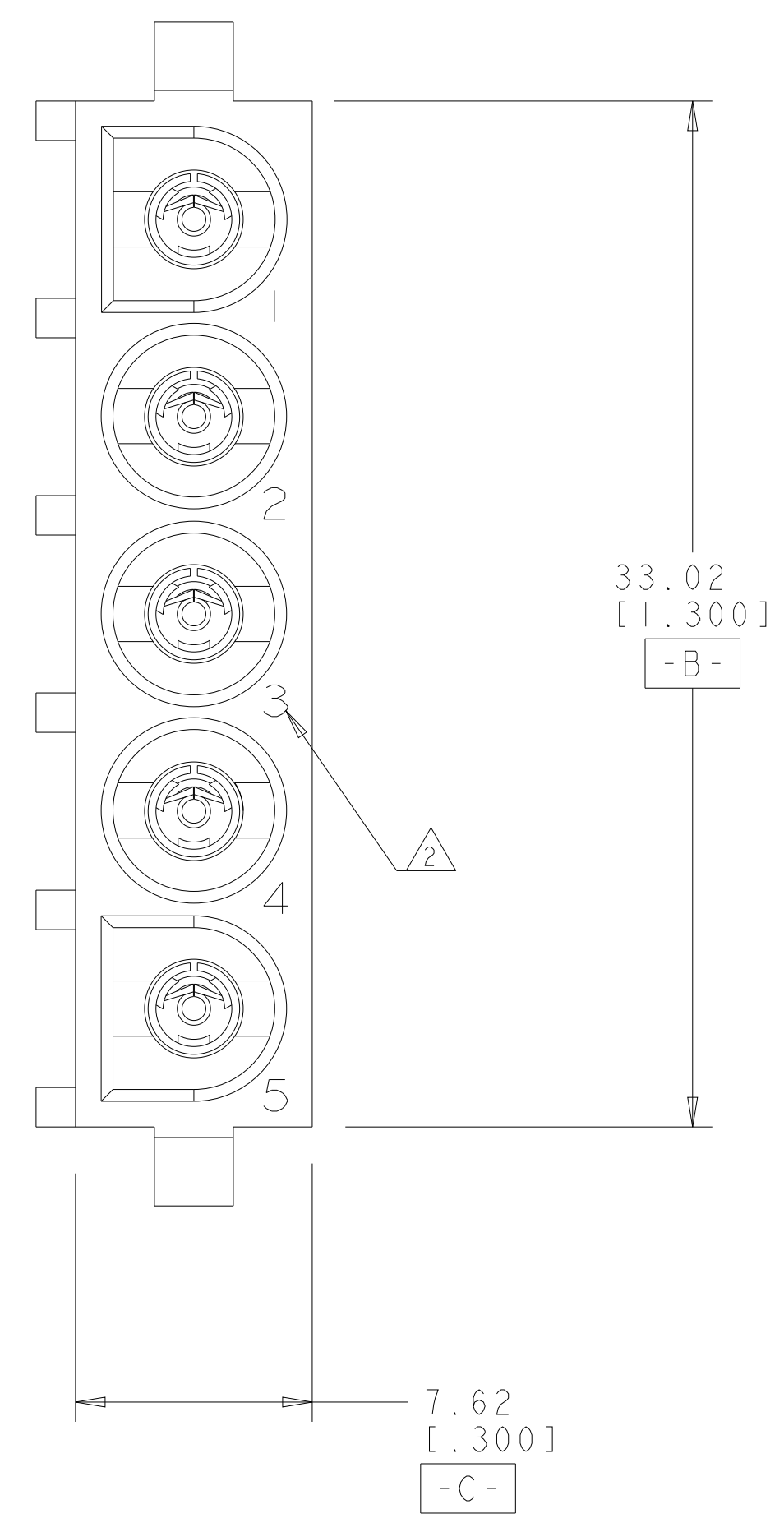
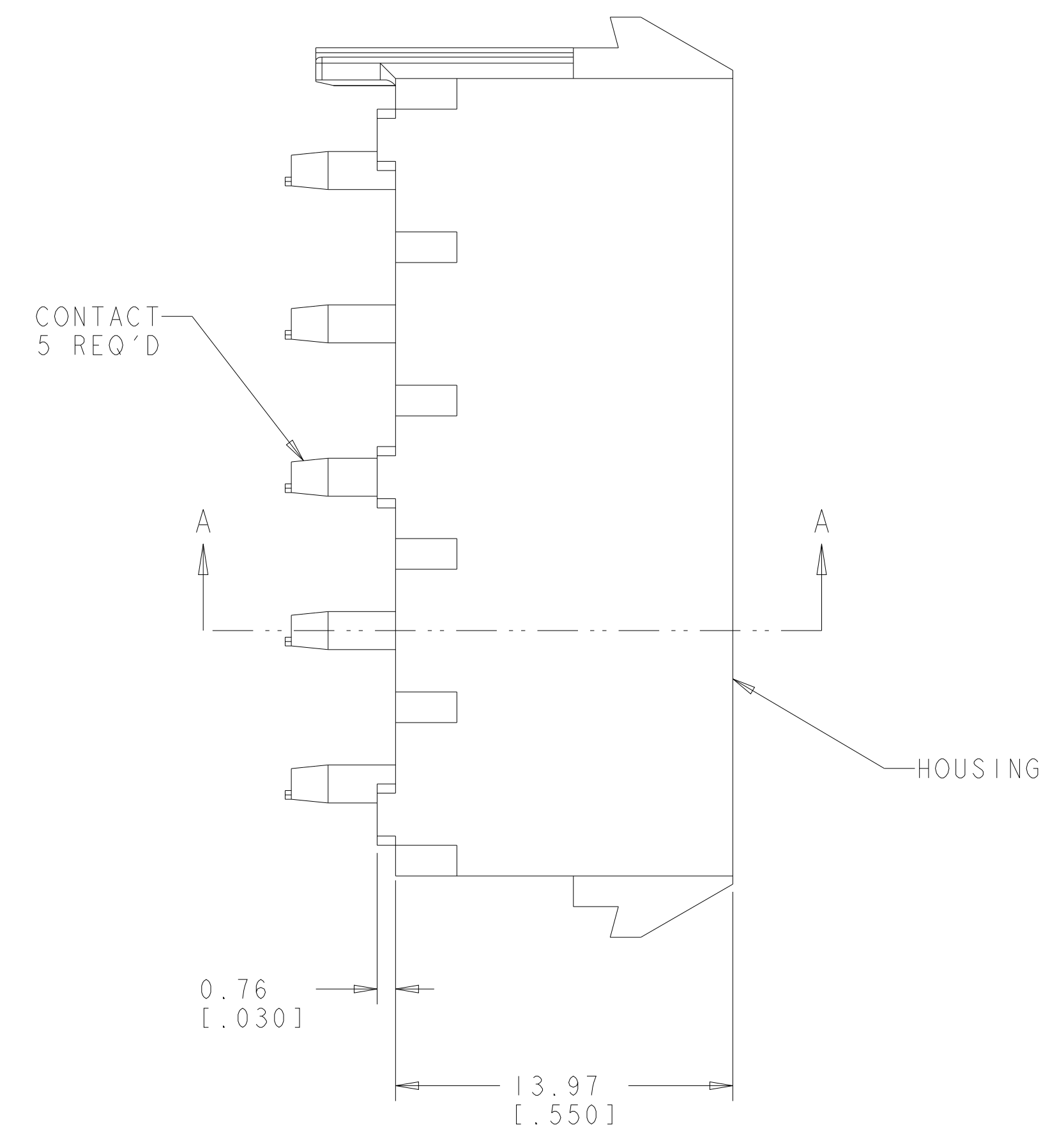
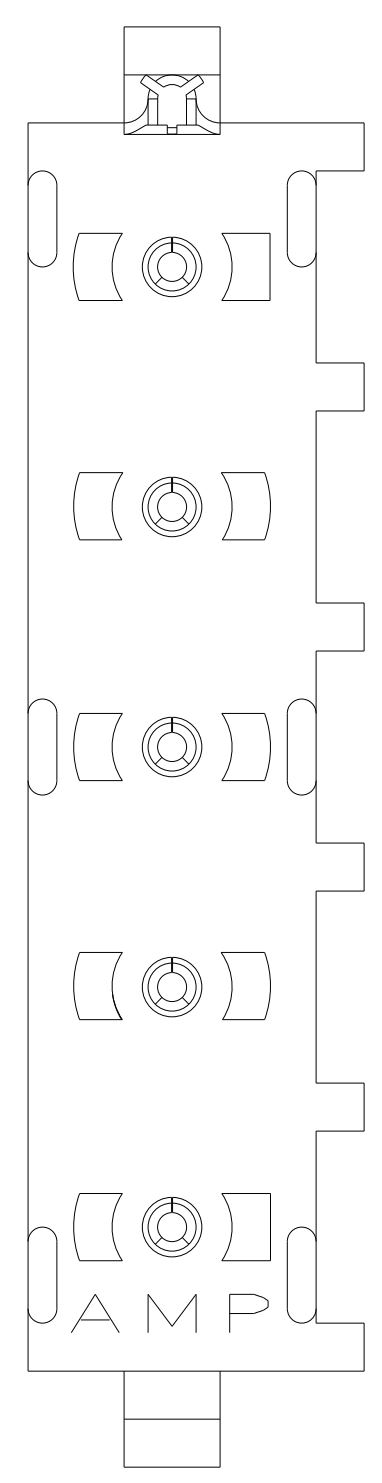
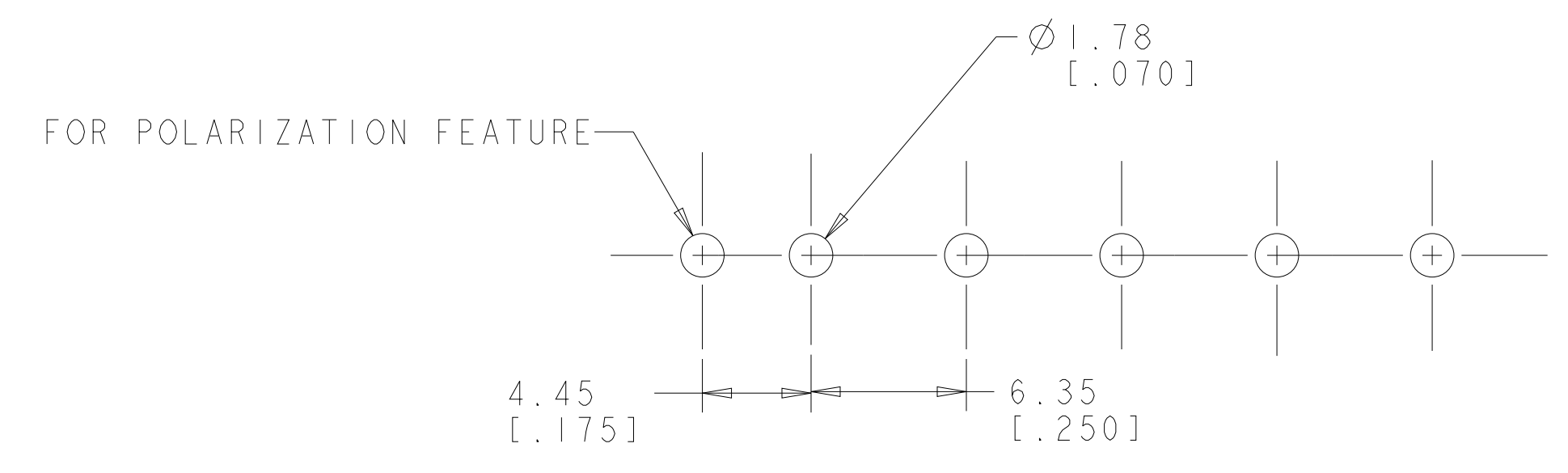

RECOMMENDED MOUNTING HOLE PATTERN FOR 1.57 [.062] THICK P.C. BOARD

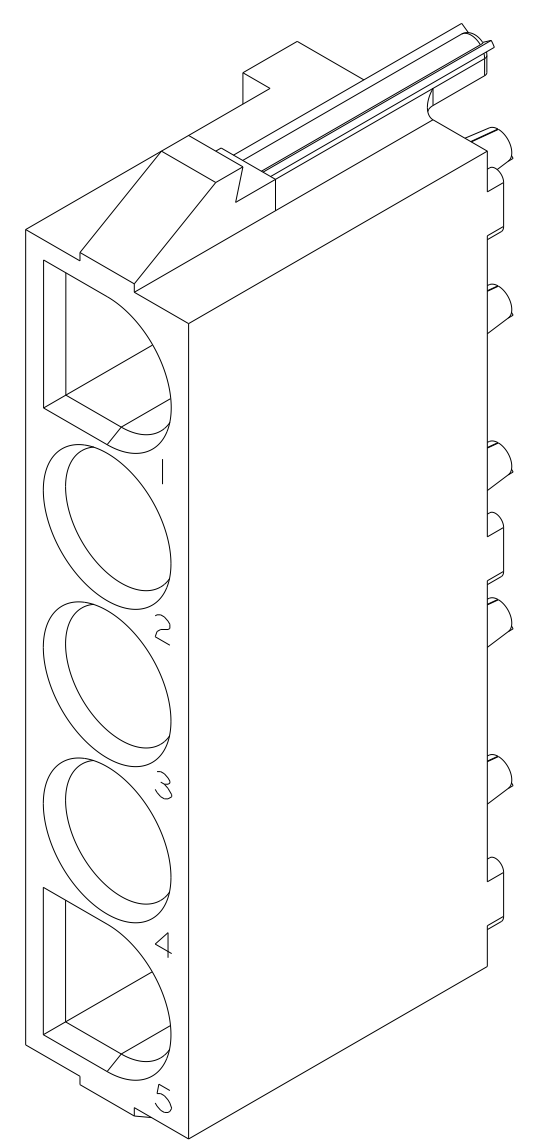

3 DIMENSIONAL MODEL SCALE 4:1

PHOSPOR BRONZE, PRE-TIN PIN CONTACT MATERIAL AND FINISH	NYLON, UL94V-0, WHITE HOUSING MATERIAL AND COLOR	794920-1 PART NUMBER
--	---	-------------------------

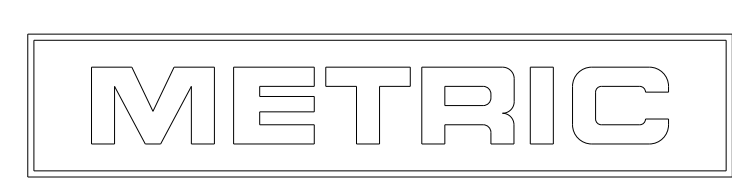

THIS DRAWING IS A CONTROLLED DOCUMENT.		DWN: K. WHITAKER 01-MAY-2001 CHK: S. RIDGILL 01-MAY-2001 APVD: S. RIDGILL 01-MAY-2001	NAME: SOCKET HEADER ASSEMBLY, POLARIZED, 5 CIRCUIT, UNIVERSAL MATE-N-LOK TM
DIMENSIONS: mm [INCHES] TOLERANCES UNLESS OTHERWISE SPECIFIED: 0 PLC ± 1 PLC ±0.131(.005) 2 PLC ± 3 PLC ± 4 PLC ± ANGLES FINISH: ±0°30'	APPLICATION SPEC: MATERIAL: SEE TABLE FINISH: SEE TABLE	SIZE: A CAGE CODE: 794920 DRAWING NO: 794920 WEIGHT: - CUSTOMER DRAWING	RESTRICTED TO: - SCALE: 5:1 SHEET: 1 OF 1 REV: A