

THIS DRAWING IS UNPUBLISHED. RELEASED FOR PUBLICATION
 © COPYRIGHT 2011 BY TYCO ELECTRONICS CORPORATION. ALL RIGHTS RESERVED.

LOC DW	DIST	REVISIONS			
P	LTR	DESCRIPTION	DATE	DWN	APVD
G		ECR-12-012115	26OCT'12	E.L.	W.K.

- NOTES:
- MATERIAL:
 - HOUSING : PA9T WITH 30% GF, UL94 V-0, BLACK COLOR.
 - INSERT HOUSING: PA46 WITH 30% GF, UL94 V-0, BLACK COLOR.
 - CONTACT: PHOSPHOR BRONZE.
 - SHELL: BRASS.
 - FINISH:
 - CONTACT: (SEE TABLE) GOLD PLATED ON CONTACT AREA. GOLD FLASH ON SOLDER TAIL.
 - SHELL: 0.508um [20u"] MIN. NICKEL PLATED.
 - REFLOW SOLDER CAPABLE TO 260°C PER TE SPEC. 109-201, CONDITION B.

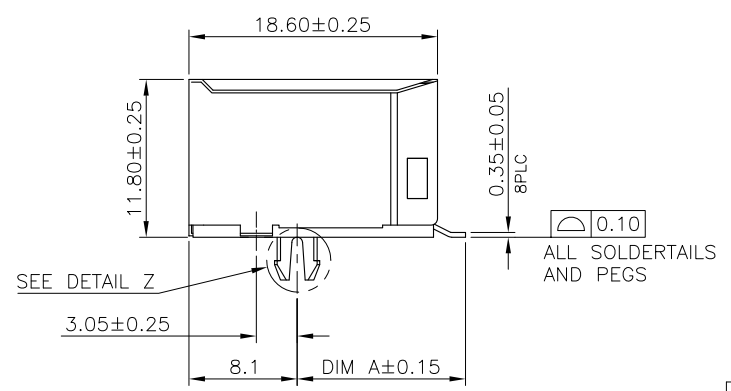
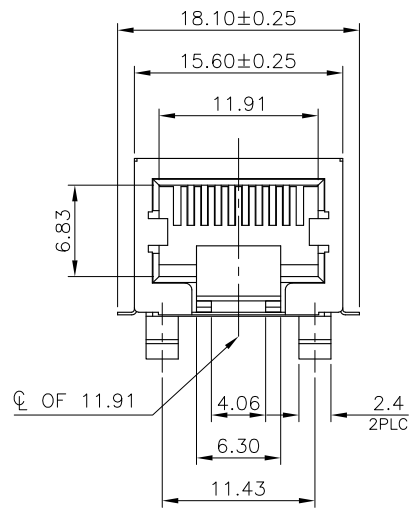
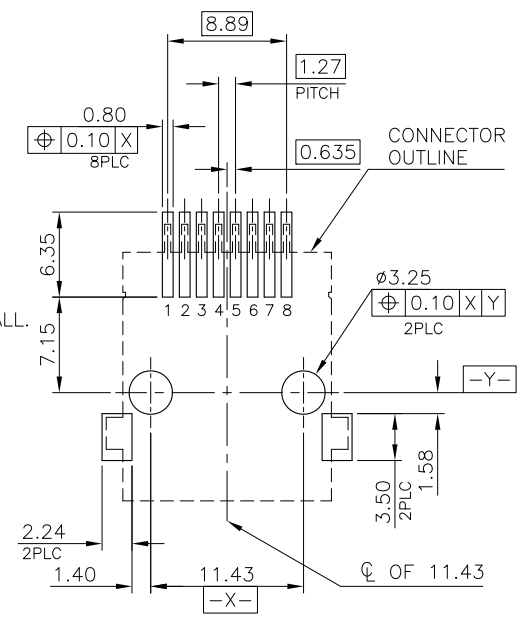
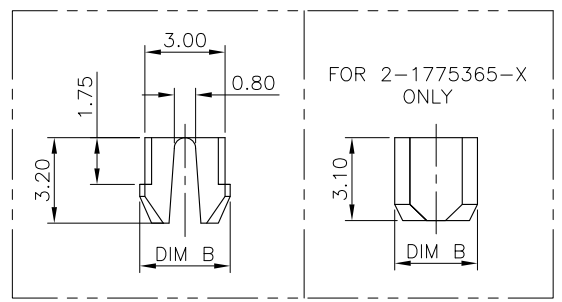
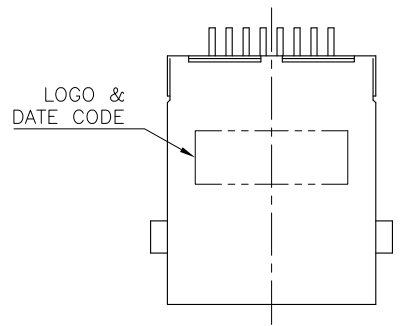

OBSOLETE

4.29	REEL TRAY	3.10	12.60	0.152um [6u"]	2-1775365-5
4.2200	REEL	3.38	12.75	1.27um [50u"]	2-1775365-1
				0.762um [30u"]	1-1775365-3
				0.381um [15u"]	1-1775365-2
				0.152um [6u"]	1-1775365-4
				1.27um [50u"]	1-1775365-4
PRODUCT WEIGHT /PCS (g)	PACKAGE	DIM B	DIM A	0.762um [30u"]	1-1775365-3
				0.381um [15u"]	1-1775365-2
				0.152um [6u"]	1775365-1
				MIN. GOLD THICKNESS	PART NUMBER

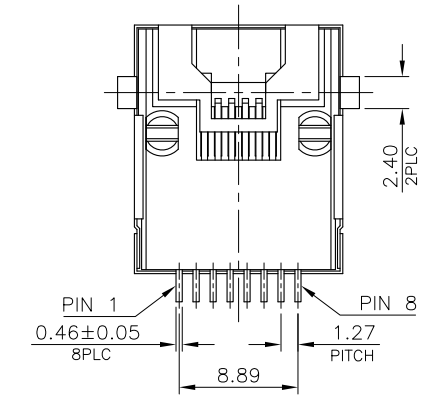
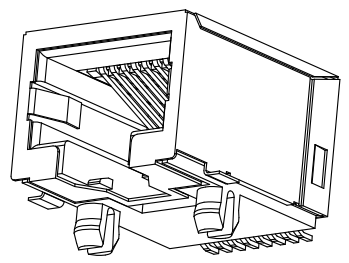

THIS DRAWING IS A CONTROLLED DOCUMENT.		DWN B. HSING	18SEP2008	TE Connectivity	
DIMENSIONS: mm		CHK S. CHIEN	18SEP2008		
TOLERANCES UNLESS OTHERWISE SPECIFIED:		APVD W. KODAMA	18SEP2008	NAME	
0 PLC ± - 1 PLC ± 0.3 2 PLC ± 0.2 3 PLC ± 0.15 4 PLC ± - ANGLES ± ± 3°		PRODUCT SPEC		MODULAR JACK CONNECTOR RJ45 ASSY, SIDE ENTRY, SHIELDED, TAB DOWN, SMT TYPE, H=11.8mm	
MATERIAL SEE NOTE		APPLICATION SPEC		SIZE	RESTRICTED TO
FINISH SEE NOTE		WEIGHT SEE TABLE		CAGE CODE A300779	DRAWING NO C=1775365
CUSTOMER DRAWING		SCALE		SHEET 1 OF 3	REV G

THIS DRAWING IS UNPUBLISHED. RELEASED FOR PUBLICATION
 © COPYRIGHT 2011 BY TYCO ELECTRONICS CORPORATION. ALL RIGHTS RESERVED.

LOC	DW	DIST	REVISIONS			
P	LTR	DESCRIPTION	DATE	DWN	APVD	
		SEE SHEET 1.				

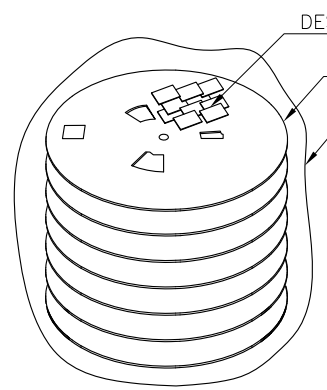
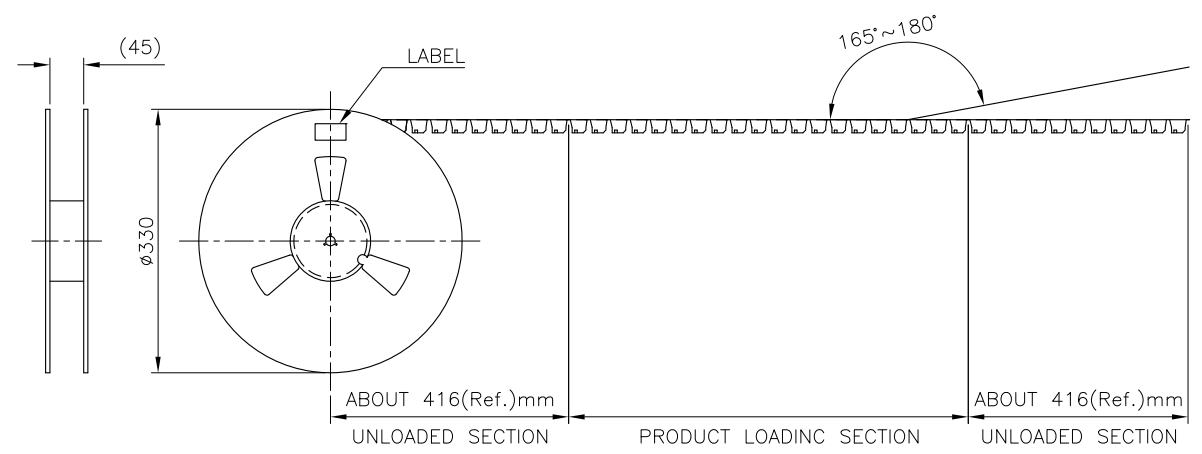

- NOTE:
1. EACH BAG SHALL BE INCLUDED: *DESICCANT
 2. PEELING STRENGTH: 0.1~1.3N(1~130 GRAMS) FOR 12~56mm WIDE CARRIER TAPES
 3. PEELING SPEED: 300mm/MINUTES.
 4. PACKAGING MATERIAL:
 - 4.1 COVER TAPE: COMPOSITE OF POLYETHYLENE TEREPHTHALATE (PET)
 - 4.2 CARRIER: POLYSTYRENE (PS)
 - 4.3 CARRIER REEL: POLYSTYRENE

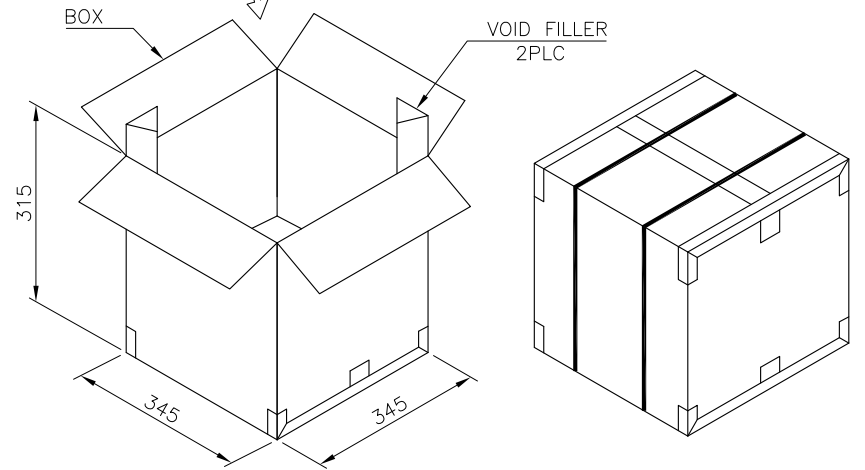
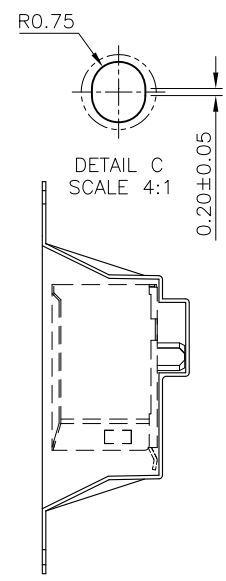
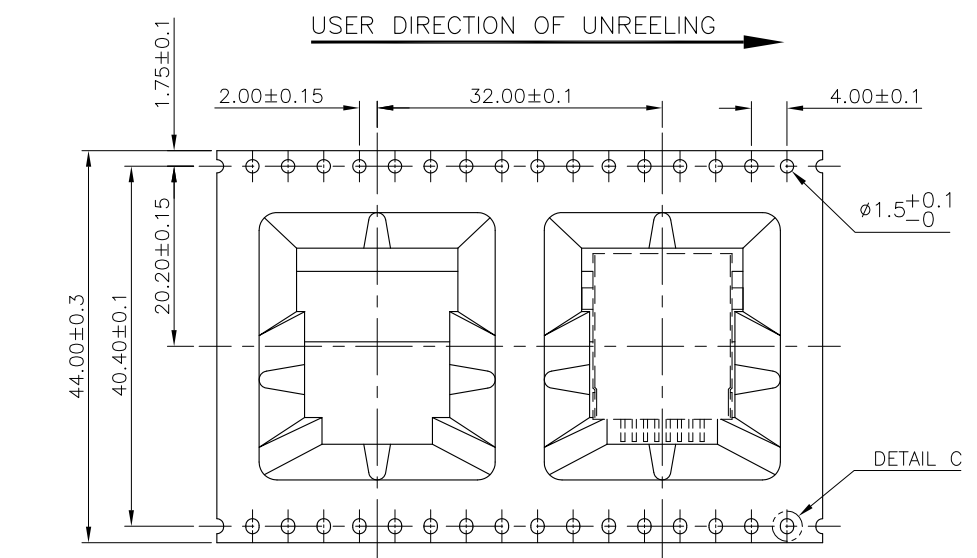

5.9 KG	2.84 KG				2-1775365-5
5.85 KG	2.79 KG	110	6	660	1-1775365-X 1775365-X
GROSS WEIGHT	NET WEIGHT	PCS/ REEL	REEL/ BOX	PCS/ BOX	PART NUMBER

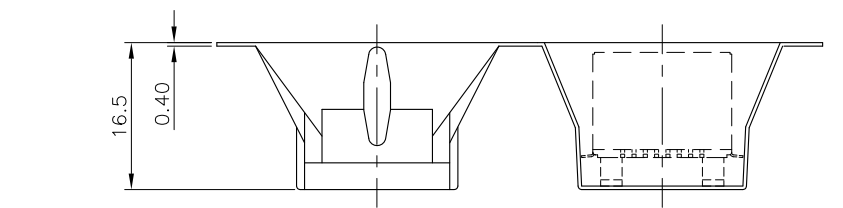

THIS DRAWING IS A CONTROLLED DOCUMENT.

DIMENSIONS: mm	TOLERANCES UNLESS OTHERWISE SPECIFIED:	DWN	TE Connectivity
	0 PLC ±	CHK	NAME
	1 PLC ±0.3	APVD	PRODUCT SPEC
	2 PLC ±0.2	PRODUCT SPEC	APPLICATION SPEC
	3 PLC ±0.15	APPLICATION SPEC	WEIGHT
	4 PLC ±	WEIGHT	SIZE
	ANGLES ± 3'	CUSTOMER DRAWING	CAGE CODE
MATERIAL	FINISH	SCALE	DRAWING NO
		SHEET	RESTRICTED TO
		2 of 3	A3 00779 C=1775365
		REV	G

THIS DRAWING IS UNPUBLISHED. RELEASED FOR PUBLICATION
 © COPYRIGHT 2011 BY TYCO ELECTRONICS CORPORATION. ALL RIGHTS RESERVED.

LOC	DIST	REVISIONS					
DW		P	LTR	DESCRIPTION	DATE	DWN	APVD
				SEE SHEET 1.			

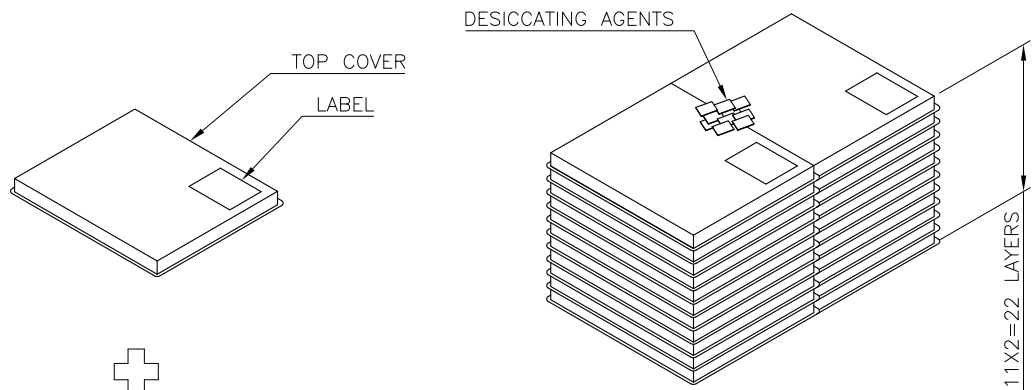

- NOTES:
- MATERIAL:
 - 1.1 TRAY: PVC.
 - 1.2 BOX: CORRUGATED FIBER.
 - DIMENSION: SEE DRAWING
 - QUANTITY: SEE TABLE
 - WEIGHT: SEE TABLE
 - EACH BAG SHALL BE INCLUDED: DESICCANT

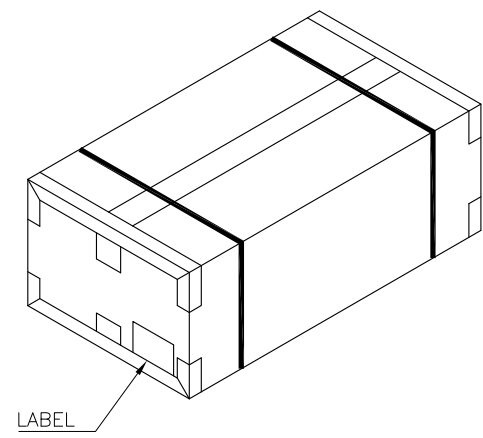
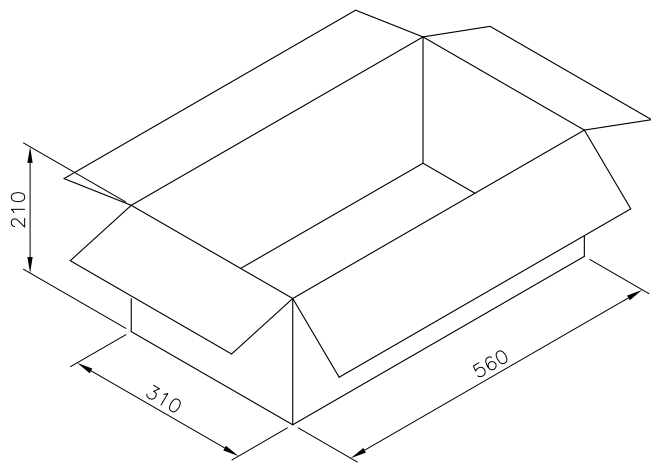
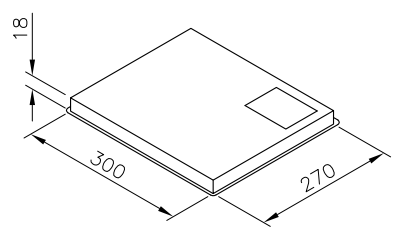
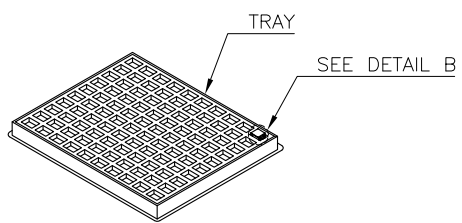

14.1 KG	9.5 KG	100	22	2200	2-1775365-1
GROSS WEIGHT	NET WEIGHT	PCS/ TRAY	TRAY/ BOX	PCS/ BOX	PART NUMBER

THIS DRAWING IS A CONTROLLED DOCUMENT.		DWN	-		
DIMENSIONS: mm		CHK	-		
TOLERANCES UNLESS OTHERWISE SPECIFIED:		APVD	-		
0 PLC ± -		PRODUCT SPEC	-		
1 PLC ± 0.3		APPLICATION SPEC	-		
2 PLC ± 0.2		WEIGHT	-		
3 PLC ± 0.15		CUSTOMER DRAWING	-		
4 PLC ± -		SCALE	-		
ANGLES ± 3'		SHEET	3 of 3		
MATERIAL		FINISH	-		
-		REV	G		

STE TE Connectivity

MODULAR JACK CONNECTOR
 RJ45 ASSY, SIDE ENTRY, SHIELDED,
 TAB DOWN, SMT TYPE, H=11.8mm

SIZE: A3 CAGE CODE: 00779 DRAWING NO: C=1775365 RESTRICTED TO: -