

### FEATURES

Operates at Supply Voltages 2 V to 12 V  
Fixed 3.3 V, 5 V, 12 V and Adjustable Output  
Minimum External Components Required  
Ground Current: 320  $\mu$ A  
Oscillator Frequency: 120 kHz  
Logic Shutdown  
8-Lead DIP and SO-8 Packages

### APPLICATIONS

Cellular Telephones  
Single-Cell to 5 V Converters  
Laptop and Palmtop Computers  
Pagers  
Cameras  
Battery Backup Supplies  
Portable Instruments  
Laser Diode Drivers  
Hand-Held Inventory Computers

### GENERAL DESCRIPTION

The ADP1109 is a versatile step-up switching regulator. The device requires only minimal external components to operate as a complete switching regulator.

The ADP1109-5 can deliver 100 mA at 5 V from a 3 V input and the ADP1109-12 can deliver 60 mA at 12 V from a 5 V input. The device also features a logic controlled shutdown capability that, when a logic low is applied, will shut down the oscillator.

The 120 kHz operating frequency allows for the use of small surface mount components. The gated oscillator capability eliminates the need for frequency compensation.

### FUNCTIONAL BLOCK DIAGRAMS

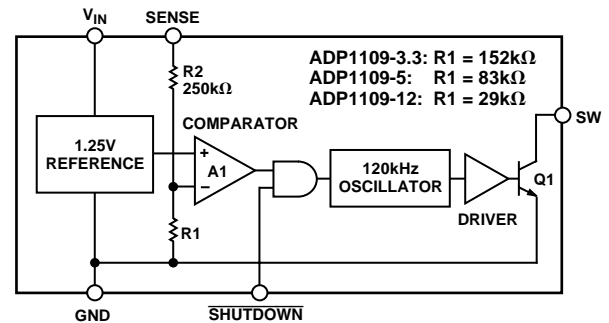

Fixed Output

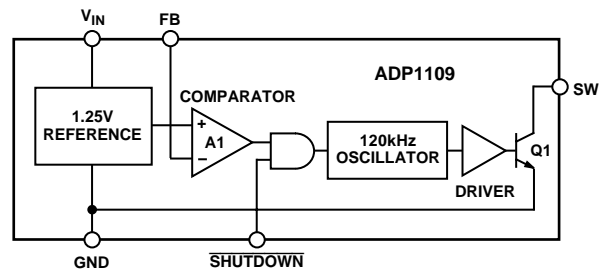

Adjustable Output

### TYPICAL APPLICATION

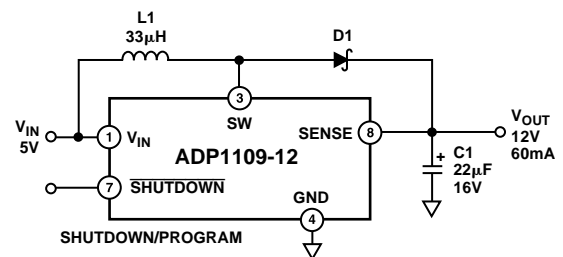

Flash Memory VPP Generator

REV. 0

Information furnished by Analog Devices is believed to be accurate and reliable. However, no responsibility is assumed by Analog Devices for its use, nor for any infringements of patents or other rights of third parties which may result from its use. No license is granted by implication or otherwise under any patent or patent rights of Analog Devices.

# ADP1109—SPECIFICATIONS ( $0^{\circ}\text{C} \leq T_A \leq +70^{\circ}\text{C}$ , $V_{IN} = 3\text{ V}$ unless otherwise noted)

Parameter	Conditions	Symbol	Min	Typ	Max	Units
QUIESCENT CURRENT	Switch Off	$I_Q$		450	590	$\mu\text{A}$
INPUT VOLTAGE		$V_{IN}$	2		9	V
COMPARATOR TRIP POINT VOLTAGE			1.20	1.25	1.30	V
COMPARATOR HYSTERESIS	ADP1109			8	14	mV
OUTPUT VOLTAGE		$V_{OUT}$				V
ADP1109-3.3	$2\text{ V} \leq V_{IN} \leq 3\text{ V}$		3.13	3.30	3.46	V
ADP1109-5	$3\text{ V} \leq V_{IN} \leq 5\text{ V}$		4.75	5.00	5.25	V
ADP1109-12	$3\text{ V} \leq V_{IN} \leq 12\text{ V}$		11.45	12.00	12.55	V
OUTPUT VOLTAGE RIPPLE						mV
ADP1109-3.3				16	40	mV
ADP1109-5				20	50	mV
ADP1109-12				40	110	mV
OSCILLATOR FREQUENCY	$T_A = +25^{\circ}\text{C}$	$f_{OSC}$	100	120	140	kHz
			90		155	kHz
DUTY CYCLE	Full Load	DC	40	50	70	%
SWITCH-ON TIME	$T_A = +25^{\circ}\text{C}$	$t_{ON}$	3.1	4.2	5.9	$\mu\text{s}$
			3.0		6.5	$\mu\text{s}$
SWITCH SATURATION VOLTAGE		$V_{CESAT}$				V
ADP1109-3.3	$I_{SW} = 500\text{ mA}$ $V_{IN} = 3\text{ V}$			0.4	0.8	V
ADP1109-5	$V_{IN} = 3\text{ V}$			0.4	0.8	V
ADP1109-12	$V_{IN} = 5\text{ V}$			0.4	0.8	V
SWITCH LEAKAGE CURRENT	$V_{SW} = 12\text{ V}$ , $T_A = +25^{\circ}\text{C}$			1	10	$\mu\text{A}$
SHUTDOWN PIN HIGH		$V_{IH}$	2.0			V
SHUTDOWN PIN LOW		$V_{IL}$			0.8	V
SHUTDOWN PIN INPUT CURRENT	$V_{SHUTDOWN} = 2\text{ V}$	$I_{IH}$			10	$\mu\text{A}$
SHUTDOWN PIN INPUT CURRENT	$V_{SHUTDOWN} = 0.8\text{ V}$	$I_{IL}$			20	$\mu\text{A}$

## NOTES

All limits at temperature extremes are guaranteed via correlation using standard quality control methods.

Specifications subject to change without notice.

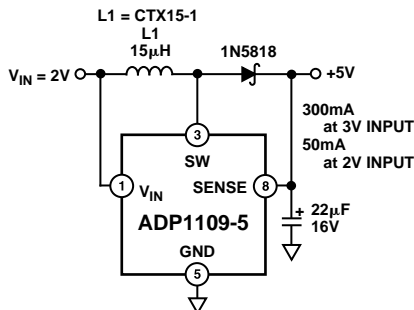

Figure 1. 2 V to 5 V Converter

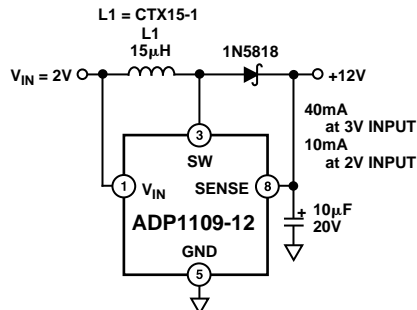

Figure 2. 2 V to 12 V Converter

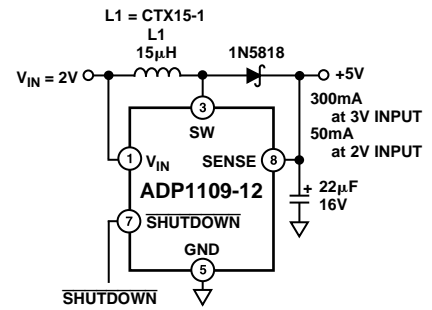

Figure 3. 2 V to 5 V Converter With Shutdown

**ABSOLUTE MAXIMUM RATINGS\***

Supply Voltage, $V_{OUT}$ .....	-0.4 V to 20 V
SW Pin Voltage .....	-0.4 V to 50 V
Shutdown Pin Voltage .....	6.0 V
Switch Current .....	1.2 A
Maximum Power Dissipation .....	300 mW
Operating Temperature Range .....	0°C to +70°C
Storage Temperature Range .....	-65°C to +150°C
Lead Temperature (Soldering, 10 sec) .....	+300°C

\*This is a stress rating only; operation beyond these limits can cause the device to be permanently damaged.

**ORDERING GUIDE**

Model	Output Voltage	Package Description	Package Options
ADP1109AN	ADJ	Plastic DIP	N-8
ADP1109AR	ADJ	Small Outline IC	SO-8
ADP1109AN-3.3	3.3 V	Plastic DIP	N-8
ADP1109AR-3.3	3.3 V	Small Outline IC	SO-8
ADP1109AN-5	5 V	Plastic DIP	N-8
ADP1109AR-5	5 V	Small Outline IC	SO-8
ADP1109AN-12	12 V	Plastic DIP	N-8
ADP1109AR-12	12 V	Small Outline IC	SO-8

**PIN FUNCTION DESCRIPTIONS**

Pin	Mnemonic	Function
1	$V_{IN}$	Input Supply Voltage.
2, 5, 6	NC	No Connection.
3	SW	Collector Node of Power Transistor.
4	GND	Ground.
7	$\overline{SHUTDOWN}$	When logic low is applied to this pin, oscillator is shut down.
8	FB(SENSE)	On the ADP1109A (Adjustable), this pin goes directly to the comparator input. On the ADP1109-3.3, ADP1109-5 and ADP1109-12, this pin is connected through the internal resistor that sets the output voltage.

**PIN CONFIGURATIONS**

**8-Lead Plastic DIP (N-8)**

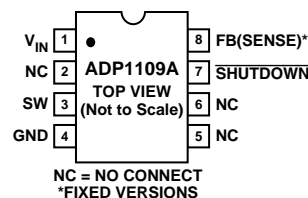

**8-Lead SOIC (SO-8)**

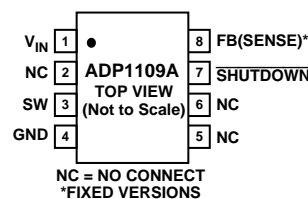

**CAUTION**

ESD (electrostatic discharge) sensitive device. Electrostatic charges as high as 4000 V readily accumulate on the human body and test equipment and can discharge without detection. Although the ADP1109 features proprietary ESD protection circuitry, permanent damage may occur on devices subjected to high energy electrostatic discharges. Therefore, proper ESD precautions are recommended to avoid performance degradation or loss of functionality.



# ADP1109—Typical Performance Characteristics

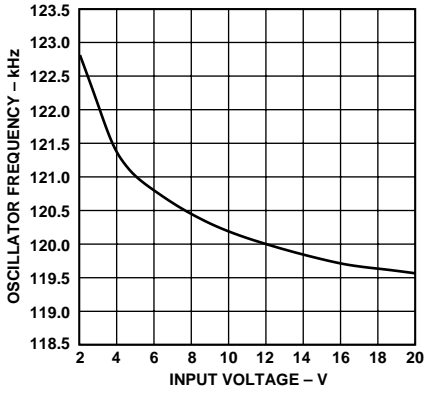

Figure 4. Oscillator Frequency vs. Input Voltage

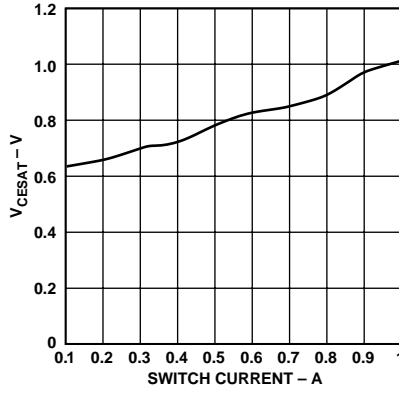

Figure 5. Switch Saturation Voltage vs. Switch Current

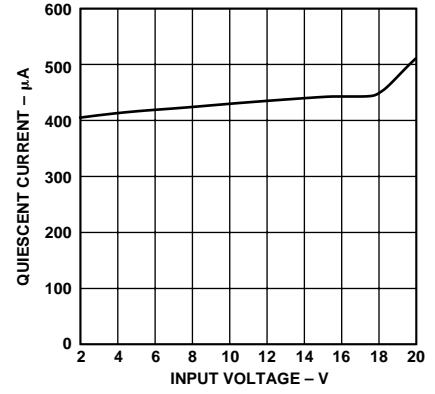

Figure 6. Quiescent Current vs. Input Voltage

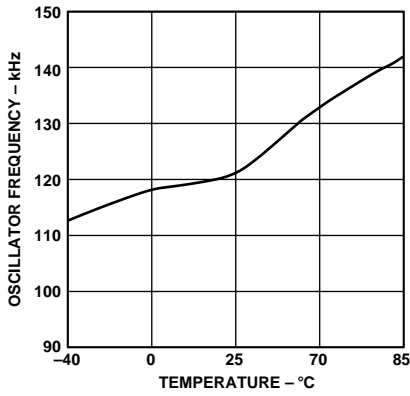

Figure 7. Oscillator Frequency vs. Temperature

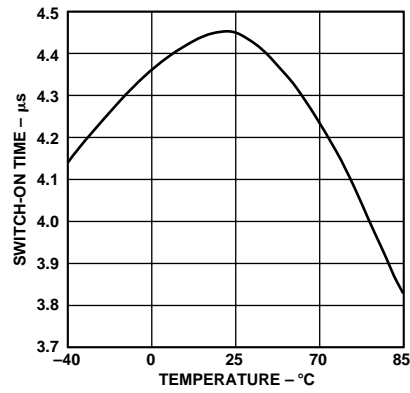

Figure 8. Switch-On Time vs. Temperature

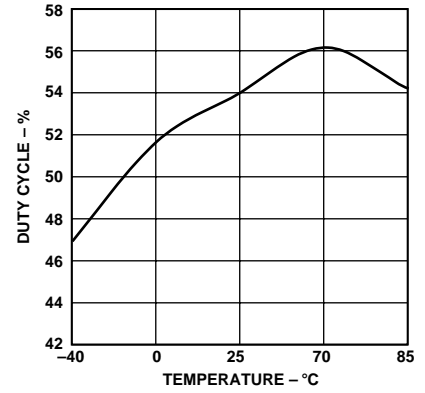

Figure 9. Duty Cycle vs. Temperature

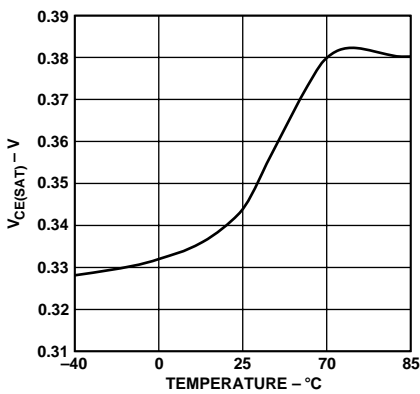

Figure 10. Switch Saturation Voltage vs. Temperature

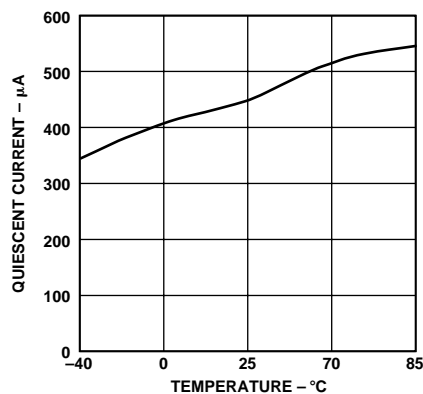

Figure 11. Quiescent Current vs. Temperature

## APPLICATION INFORMATION

### THEORY OF OPERATION

The ADP1109 is a flexible, low power switch-mode power supply (SMPS) controller for step-up dc/dc converter applications. This device uses a gated-oscillator technique to provide very high performance with low quiescent current. For example, more than 2 W of output power can be generated from a +5 V source, while quiescent current is only 450  $\mu$ A.

A functional block diagram of the ADP1109 is shown on page 1. The internal 1.25 V reference is connected to one input of the comparator, while the other input is externally connected (via the FB pin) to a feedback network connected to the regulated output. When the voltage at the FB pin falls below 1.25 V, the 120 kHz oscillator turns on. A driver amplifier provides base drive to the internal power switch, and the switching action raises the output voltage. When the voltage at the FB pin exceeds 1.25 V, the oscillator is shut off. While the oscillator is off, the ADP1109 quiescent current is only 450  $\mu$ A. The comparator includes a small amount of hysteresis, which ensures loop stability without requiring external components for frequency compensation.

A shutdown feature permits the oscillator to be shut off. Holding **SHUTDOWN** low will disable the oscillator, and the ADP1109's quiescent current will remain 450  $\mu$ A.

The output voltage of the ADP1109 is set with two external resistors. Three fixed-voltage models are also available: the ADP1109-3.3 (+3.3 V), ADP1109-5 (+5 V) and ADP1109-12 (+12 V). The fixed-voltage models are identical to the ADP1109, except that laser-trimmed voltage-setting resistors are included on the chip. On the fixed-voltage models of the ADP1109, simply connect the SENSE pin (Pin 8) directly to the output voltage.

### COMPONENT SELECTION

#### General Notes on Inductor Selection

When the ADP1109 internal power switch turns on, current begins to flow in the inductor. Energy is stored in the inductor core while the switch is on, and this stored energy is then transferred to the load when the switch turns off.

To specify an inductor for the ADP1109, the proper values of inductance, saturation current and dc resistance must be determined. This process is not difficult, and specific equations are provided in this data sheet. In general terms, however, the inductance value must be low enough to store the required amount of energy (when both input voltage and switch ON time are at a minimum), but high enough that the inductor will not saturate when both  $V_{IN}$  and switch ON time are at their maximum values. The inductor must also store enough energy to supply the load, without saturating. Finally, the dc resistance of the inductor should be low, so that excessive power will not be wasted by heating the windings. For most ADP1109 applications, an inductor of 10  $\mu$ H to 47  $\mu$ H, with a saturation current rating of 300 mA to 1 A and dc resistance  $<0.4 \Omega$  is suitable. Ferrite core inductors that meet these specifications are available in small, surface-mount packages. Air-core inductors, as well as RF chokes, are unsuitable because of their low peak current ratings.

The ADP1109 is designed for applications where the input voltage is fairly stable, such as generating +12 V from a +5 V logic supply. The ADP1109 does not have an internal switch current limiting circuit, so the inductor may saturate if the input voltage is too high. The ADP1111 or ADP3000 should be considered for battery powered and similar applications where the input voltage varies.

To minimize Electro-Magnetic Interference (EMI), a toroid or pot core type inductor is recommended. Rod core inductors are a lower cost alternative if EMI is not a problem.

#### Calculating the Inductor Value

Selecting the proper inductor value is a simple, two-step process:

1. Define the operating parameters: minimum input voltage, maximum input voltage, output voltage and output current.
2. Calculate the inductor value, using the equations in the following section.

#### Inductor Selection

In a step-up, or boost, converter (Figure 1), the inductor must store enough power to make up the difference between the input voltage and the output voltage. The inductor power is calculated from the equation:

$$P_L = (V_{OUT} + V_D - V_{IN(MIN)}) \times (I_{OUT}) \quad (1)$$

where  $V_D$  is the diode forward voltage ( $\approx 0.5$  V for a 1N5818 Schottky). Energy is stored in the inductor only while the ADP1109 switch is ON, so the energy stored in the inductor on each switching cycle must be equal to or greater than:

$$\frac{P_L}{f_{OSC}} \quad (2)$$

in order for the ADP1109 to regulate the output voltage. When the internal power switch turns ON, current flow in the inductor increases at the rate of:

$$I_L(t) = \frac{V_{IN}}{R'} \left( 1 - e^{-\frac{R't}{L}} \right) \quad (3)$$

where  $L$  is in Henrys and  $R'$  is the sum of the switch equivalent resistance (typically  $0.8 \Omega$  at  $+25^\circ\text{C}$ ) and the dc resistance of the inductor. In most applications, the voltage drop across the switch is small compared to  $V_{IN}$  so a simpler equation can be used:

$$I_L(t) = \frac{V_{IN}}{L} t \quad (4)$$

Replacing  $t$  in the above equation with the ON time of the ADP1109 (5.5  $\mu$ s, typical) will define the peak current for a given inductor value and input voltage. At this point, the inductor energy can be calculated as follows:

$$E_L = \frac{1}{2} L \times I^2_{peak} \quad (5)$$

# ADP1109

As previously mentioned,  $E_L$  must be greater than  $P_L/f_{OSC}$  so that the ADP1109 can deliver the necessary power to the load. For best efficiency, peak current should be limited to 1 A or less. Higher switch currents will reduce efficiency because of increased saturation voltage in the switch. High peak current also increases output ripple. As a general rule, keep peak current as low as possible to minimize losses in the switch, inductor and diode.

In practice, the inductor value is easily selected using the equations above. For example, consider a supply that will generate 12 V at 120 mA from a +5 V source. The inductor power required is, from Equation 1:

$$P_L = (12\text{ V} + 0.5\text{ V} - 5\text{ V}) \times (120\text{ mA}) = 900\text{ mW} \quad (6)$$

On each switching cycle, the inductor must supply:

$$\frac{P_L}{f_{OSC}} = \frac{900\text{ mW}}{120\text{ kHz}} = 7.5\text{ }\mu\text{J} \quad (7)$$

The required inductor power is fairly low in this example, so the peak current can also be low. Assuming a peak current of 600 mA as a starting point, Equation 4 can be rearranged to recommend an inductor value:

$$L = \frac{V_{IN}}{I_{L(MAX)}} t = \frac{5\text{ V}}{600\text{ mA}} 5.5\text{ }\mu\text{s} = 45.8\text{ }\mu\text{H} \quad (8)$$

Substituting a standard inductor value of 33  $\mu\text{H}$ , with 0.2  $\Omega$  dc resistance, will produce a peak switch current of:

$$I_{PEAK} = \frac{5\text{ V}}{1.0\text{ }\Omega} \left( 1 - e^{\frac{-1.0\text{ }\Omega \times 5.5\text{ }\mu\text{s}}{33\text{ }\mu\text{H}}} \right) = 768\text{ mA} \quad (9)$$

Once the peak current is known, the inductor energy can be calculated from Equation 5:

$$E_L = \frac{1}{2} (33\text{ }\mu\text{H}) \times (768\text{ mA})^2 = 9.7\text{ }\mu\text{J} \quad (10)$$

The inductor energy of 9.7  $\mu\text{J}$  is greater than the  $P_L/f_{OSC}$  requirement of 7.5  $\mu\text{J}$ , so the 33  $\mu\text{H}$  inductor will work in this application. By substituting other inductor values into the same equations, the optimum inductor value can be selected. When selecting an inductor, the peak current must not exceed the maximum switch current of 1.2 A. If the calculated peak current is greater than 1.2 A, either the input voltage must be increased or the load current decreased.

## Output Voltage Selection

The output voltage is fed back to the ADP1109 via resistors R1 and R2 (Figure 5). When the voltage at the comparator's inverting input falls below 1.25 V, the oscillator turns "on" and the output voltage begins to rise. The output voltage is therefore set by the formula:

$$V_{OUT} = 1.25\text{ V} \times \left( 1 + \frac{R2}{R1} \right) \quad (11)$$

Resistors R1 and R2 are provided internally on fixed-voltage versions of the ADP1109. In this case, a complete dc-dc converter requires only four external components.

## Capacitor Selection

For optimum performance, the ADP1109's output capacitor must be carefully selected. Choosing an inappropriate capacitor can result in low efficiency and/or high output ripple.

Ordinary aluminum electrolytic capacitors are inexpensive, but often have poor Equivalent Series Resistance (ESR) and Equivalent Series Inductance (ESL). Low ESR aluminum capacitors, specifically designed for switch mode converter applications, are also available, and these are a better choice than general purpose devices. Even better performance can be achieved with tantalum capacitors, although their cost is higher. Very low values of ESR can be achieved by using OS-CON capacitors (Sanyo Corporation, San Diego, CA). These devices are fairly small, available with tape-and-reel packaging, and have very low ESR.

## Diode Selection

In specifying a diode, consideration must be given to speed, forward voltage drop and reverse leakage current. When the ADP1109 switch turns off, the diode must turn on rapidly if high efficiency is to be maintained. Schottky rectifiers, as well as fast signal diodes such as the 1N4148, are appropriate. The forward voltage of the diode represents power that is not delivered to the load, so  $V_F$  must also be minimized. Again, Schottky diodes are recommended. Leakage current is especially important in low current applications, where the leakage can be a significant percentage of the total quiescent current.

For most circuits, the 1N5818 is a suitable companion to the ADP1109. This diode has a  $V_F$  of 0.5 V at 1 A, 4  $\mu\text{A}$  to 10  $\mu\text{A}$  leakage, and fast turn-on and turn-off times. A surface mount version, the MBRS130T3, is also available.

For switch currents of 100 mA or less, a Schottky diode such as the BAT85 provides a  $V_F$  of 0.8 V at 100 mA and leakage less than 1  $\mu\text{A}$ . A similar device, the BAT54, is available in an SOT-23 package. Even lower leakage, in the 1 nA to 5 nA range, can be obtained with a 1N4148 signal diode.

General purpose rectifiers, such as the 1N4001, are not suitable for ADP1109 circuits. These devices, which have turn-on times of 10  $\mu\text{s}$  or more, are far too slow for switching power supply applications. Using such a diode "just to get started" will result in wasted time and effort. Even if an ADP1109 circuit appears to function with a 1N4001, the resulting performance will not be indicative of the circuit performance when the correct diode is used.

**OUTLINE DIMENSIONS**

Dimensions shown in inches and (mm).

**8-Lead Plastic DIP  
(N-8)**

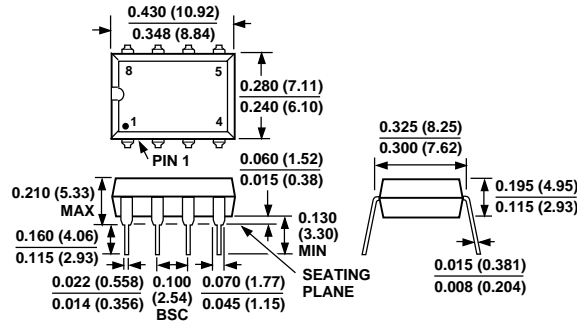

**8-Lead SOIC  
(SO-8)**

