



# 3.3V CMOS Static RAM 4 Meg (256K x 16-Bit)

**IDT71V416YS**  
**IDT71V416YL**

## Features

- ◆ 256K x 16 advanced high-speed CMOS Static RAM
- ◆ JEDEC Center Power / GND pinout for reduced noise.
- ◆ Equal access and cycle times
  - Commercial and Industrial: 10/12/15ns
- ◆ One Chip Select plus one Output Enable pin
- ◆ Bidirectional data inputs and outputs directly LVTTTL-compatible
- ◆ Low power consumption via chip deselect
- ◆ Upper and Lower Byte Enable Pins
- ◆ Single 3.3V power supply
- ◆ Available in 44-pin, 400 mil plastic SOJ package and a 44-pin, 400 mil TSOP Type II package and a 48 ball grid array, 9mm x 9mm package.

## Description

The IDT71V416 is a 4,194,304-bit high-speed Static RAM organized as 256K x 16. It is fabricated using IDT's high-performance, high-reliability CMOS technology. This state-of-the-art technology, combined with innovative circuit design techniques, provides a cost-effective solution for high-speed memory needs.

The IDT71V416 has an output enable pin which operates as fast as 5ns, with address access times as fast as 10ns. All bidirectional inputs and outputs of the IDT71V416 are LVTTTL-compatible and operation is from a single 3.3V supply. Fully static asynchronous circuitry is used, requiring no clocks or refresh for operation.

The IDT71V416 is packaged in a 44-pin, 400 mil Plastic SOJ and a 44-pin, 400 mil TSOP Type II package and a 48 ball grid array, 9mm x 9mm package.

## Functional Block Diagram

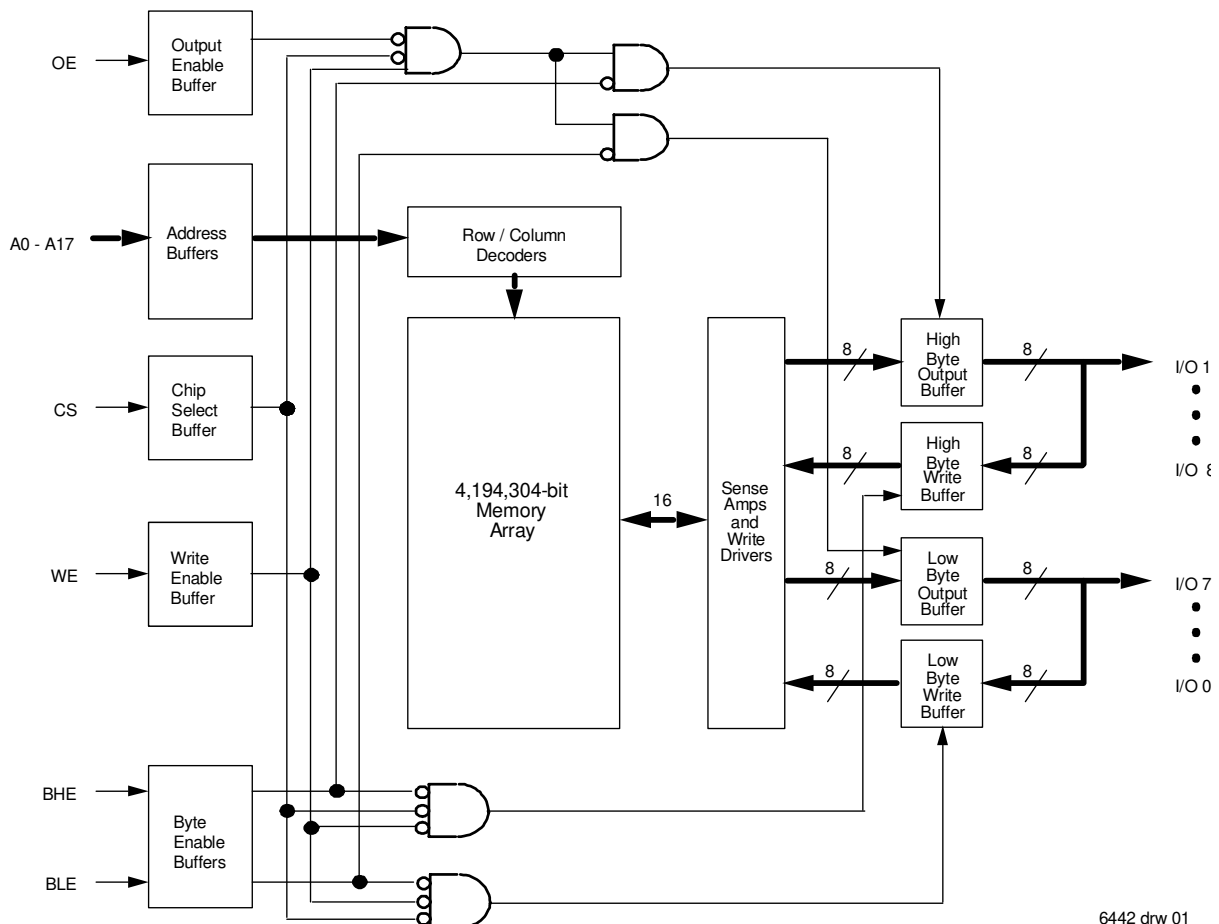

6442 drw 01

**JULY 2004**

### Pin Configurations - SOJ/TSOP

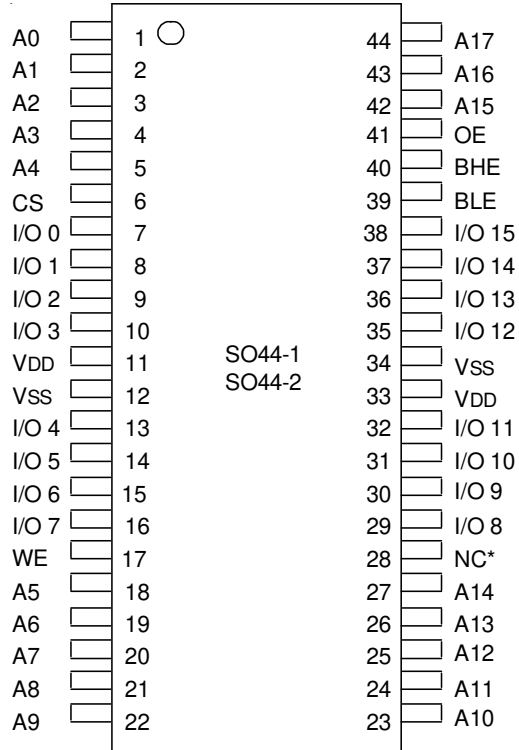

6442 drw 02

\*Pin 28 can either be a NC or connected to Vss

### Top View

#### Pin Descriptions

|                                      |                   |       |
|--------------------------------------|-------------------|-------|
| A <sub>0</sub> - A <sub>17</sub>     | Address Inputs    | Input |
| $\overline{CS}$                      | Chip Select       | Input |
| $\overline{WE}$                      | Write Enable      | Input |
| $\overline{OE}$                      | Output Enable     | Input |
| $\overline{BHE}$                     | High Byte Enable  | Input |
| $\overline{BLE}$                     | Low Byte Enable   | Input |
| I/O <sub>0</sub> - I/O <sub>15</sub> | Data Input/Output | I/O   |
| V <sub>DD</sub>                      | 3.3V Power        | Pwr   |
| V <sub>SS</sub>                      | Ground            | Gnd   |

6442 tbl 01

### Pin Configurations - 48 BGA

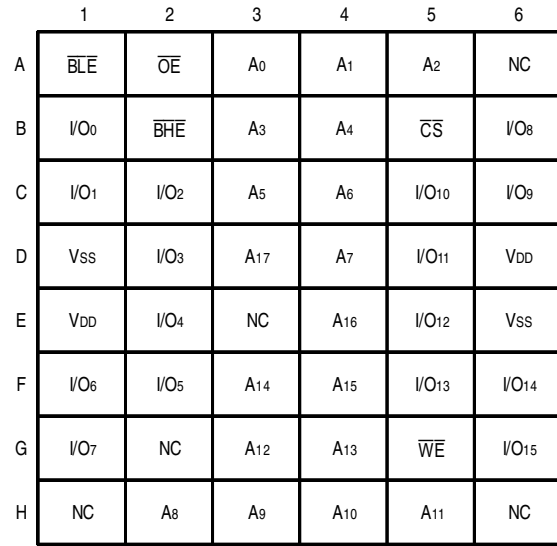

6442 tbl 11

### SOJ Capacitance

(T<sub>A</sub> = +25°C, f = 1.0MHz)

| Symbol           | Parameter <sup>(1)</sup> | Conditions             | Max. | Unit |
|------------------|--------------------------|------------------------|------|------|
| C <sub>IN</sub>  | Input Capacitance        | V <sub>IN</sub> = 3dV  | 7    | pF   |
| C <sub>I/O</sub> | I/O Capacitance          | V <sub>OUT</sub> = 3dV | 8    | pF   |

6442 tbl 02

### 48 BGA Capacitance

(T<sub>A</sub> = +25°C, f = 1.0MHz)

| Symbol           | Parameter <sup>(1)</sup> | Conditions             | Max. | Unit |
|------------------|--------------------------|------------------------|------|------|
| C <sub>IN</sub>  | Input Capacitance        | V <sub>IN</sub> = 3dV  | 6    | pF   |
| C <sub>I/O</sub> | I/O Capacitance          | V <sub>OUT</sub> = 3dV | 7    | pF   |

6442 tbl 02b

#### NOTE:

1. This parameter is guaranteed by device characterization, but not production tested.

## Absolute Maximum Ratings<sup>(1)</sup>

| Symbol                             | Rating                                       | Value                        | Unit |
|------------------------------------|--|------------------------------|------|
| V <sub>DD</sub>                    | Supply Voltage Relative to V <sub>SS</sub>   | -0.5 to +4.6                 | V    |
| V <sub>IN</sub> , V <sub>OUT</sub> | Terminal Voltage Relative to V <sub>SS</sub> | -0.5 to V <sub>DD</sub> +0.5 | V    |
| T <sub>BIAS</sub>                  | Temperature Under Bias                       | -55 to +125                  | °C   |
| T <sub>STG</sub>                   | Storage Temperature                          | -55 to +125                  | °C   |
| P <sub>T</sub>                     | Power Dissipation                            | 1                            | W    |
| I <sub>OUT</sub>                   | DC Output Current                            | 50                           | mA   |

6442 tbl 04

### NOTE:

- Stresses greater than those listed under ABSOLUTE MAXIMUM RATINGS may cause permanent damage to the device. This is a stress rating only and functional operation of the device at these or any other conditions above those indicated in the operational sections of this specification is not implied. Exposure to absolute maximum rating conditions for extended periods may affect reliability.

## Recommended Operating Temperature and Supply Voltage

| Grade      | Temperature    | V <sub>SS</sub> | V <sub>DD</sub> |
|------------|----------------|-----------------|-----------------|
| Commercial | 0°C to +70°C   | 0V              | See Below       |
| Industrial | -40°C to +85°C | 0V              | See Below       |

6442 tbl 05

## Recommended DC Operating Conditions

| Symbol          | Parameter          | Min.                | Typ. | Max.                                | Unit |
|-----------------|--------------------|---------------------|------|-------------------------------------|------|
| V <sub>DD</sub> | Supply Voltage     | 3.0                 | 3.3  | 3.6                                 | V    |
| V <sub>SS</sub> | Ground             | 0                   | 0    | 0                                   | V    |
| V <sub>IH</sub> | Input High Voltage | 2.0                 | —    | V <sub>DD</sub> +0.3 <sup>(1)</sup> | V    |
| V <sub>IL</sub> | Input Low Voltage  | -0.3 <sup>(2)</sup> | —    | 0.8                                 | V    |

6442 tbl 06

### NOTES:

- V<sub>IH</sub> (max.) = V<sub>DD</sub>+2V for pulse width less than 5ns, once per cycle.
- V<sub>IL</sub> (min.) = -2V for pulse width less than 5ns, once per cycle.

## Truth Table<sup>(1)</sup>

| $\overline{CS}$ | $\overline{OE}$ | $\overline{WE}$ | $\overline{BLE}$ | BHE | I/O <sub>0</sub> -I/O <sub>7</sub> | I/O <sub>8</sub> -I/O <sub>15</sub> | Function             |
|-----------------|-----------------|-----------------|------------------|-----|------------------------------------|-------------------------------------|----------------------|
| H               | X               | X               | X                | X   | High-Z                             | High-Z                              | Deselected - Standby |
| L               | L               | H               | L                | H   | DATA <sub>OUT</sub>                | High-Z                              | Low Byte Read        |
| L               | L               | H               | H                | L   | High-Z                             | DATA <sub>OUT</sub>                 | High Byte Read       |
| L               | L               | H               | L                | L   | DATA <sub>OUT</sub>                | DATA <sub>OUT</sub>                 | Word Read            |
| L               | X               | L               | L                | L   | DATA <sub>IN</sub>                 | DATA <sub>IN</sub>                  | Word Write           |
| L               | X               | L               | L                | H   | DATA <sub>IN</sub>                 | High-Z                              | Low Byte Write       |
| L               | X               | L               | H                | L   | High-Z                             | DATA <sub>IN</sub>                  | High Byte Write      |
| L               | H               | H               | X                | X   | High-Z                             | High-Z                              | Outputs Disabled     |
| L               | X               | X               | H                | H   | High-Z                             | High-Z                              | Outputs Disabled     |

6442 tbl 03

### NOTE:

- H = V<sub>IH</sub>, L = V<sub>IL</sub>, X = Don't care.

## DC Electrical Characteristics

(VDD = Min. to Max., Commercial and Industrial Temperature Ranges)

| Symbol          | Parameter              | Test Conditions  | IDT71V416 |      | Unit |
|-----------------|------------------------|--|-----------|------|------|
|                 |                        |  | Min.      | Max. |      |
| II <sub>L</sub> | Input Leakage Current  | V <sub>CC</sub> = Max., V <sub>IN</sub> = V <sub>SS</sub> to V <sub>DD</sub>                             | —         | 5    | μA   |
| II <sub>O</sub> | Output Leakage Current | V <sub>DD</sub> = Max., $\overline{CS} = V_{IH}$ , V <sub>OUT</sub> = V <sub>SS</sub> to V <sub>DD</sub> | —         | 5    | μA   |
| V <sub>OL</sub> | Output Low Voltage     | I <sub>OL</sub> = 8mA, V <sub>DD</sub> = Min.  | —         | 0.4  | V    |
| V <sub>OH</sub> | Output High Voltage    | I <sub>OH</sub> = -4mA, V <sub>DD</sub> = Min.   | 2.4       | —    | V    |

6442 tbl 07

## DC Electrical Characteristics<sup>(1, 2, 3)</sup>

(VDD = Min. to Max., V<sub>LC</sub> = 0.2V, V<sub>HC</sub> = V<sub>DD</sub> - 0.2V)

| Symbol           | Parameter   |   | 71V416S/L10 |                     | 71V416S/L12 |      | 71V416S/L15 |      | Unit |
|------------------|---|---|-------------|---------------------|-------------|------|-------------|------|------|
|                  |   |   | Com'l.      | Ind. <sup>(5)</sup> | Com'l.      | Ind. | Com'l.      | Ind. |      |
| I <sub>CC</sub>  | Dynamic Operating Current<br>$\overline{CS} \leq V_{LC}$ , Outputs Open, V <sub>DD</sub> = Max., f = f <sub>MAX</sub> <sup>(4)</sup>            | S | 200         | 200                 | 180         | 180  | 170         | 170  | mA   |
|                  |   | L | 180         | —                   | 170         | 170  | 160         | 160  |      |
| I <sub>SB</sub>  | Dynamic Standby Power Supply Current<br>$\overline{CS} \geq V_{HC}$ , Outputs Open, V <sub>DD</sub> = Max., f = f <sub>MAX</sub> <sup>(4)</sup> | S | 70          | 70                  | 60          | 60   | 50          | 50   | mA   |
|                  |   | L | 50          | —                   | 45          | 45   | 40          | 40   |      |
| I <sub>SB1</sub> | Full Standby Power Supply Current (static)<br>$\overline{CS} \geq V_{HC}$ , Outputs Open, V <sub>DD</sub> = Max., f = 0 <sup>(4)</sup>          | S | 20          | 20                  | 20          | 20   | 20          | 20   | mA   |
|                  |   | L | 10          | —                   | 10          | 10   | 10          | 10   |      |

6442 tbl 08

### NOTES:

- All values are maximum guaranteed values.
- All inputs switch between 0.2V (Low) and V<sub>DD</sub> - 0.2V (High).
- Power specifications are preliminary.
- f<sub>MAX</sub> = 1/trc (all address inputs are cycling at f<sub>MAX</sub>); f = 0 means no address input lines are changing.
- Standard power 10ns (S10) speed grade only.

### IDT71V416S/71V416L

## AC Test Loads

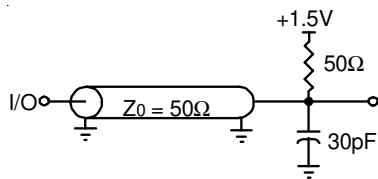

6442 drw 03

Figure 1. AC Test Load

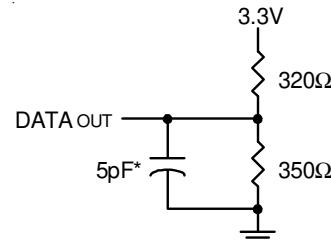

6442 drw 04

\*Including jig and scope capacitance.

Figure 2. AC Test Load

(for t<sub>CLZ</sub>, t<sub>OLZ</sub>, t<sub>CHZ</sub>, t<sub>OHZ</sub>, t<sub>OW</sub>, and t<sub>WHZ</sub>)

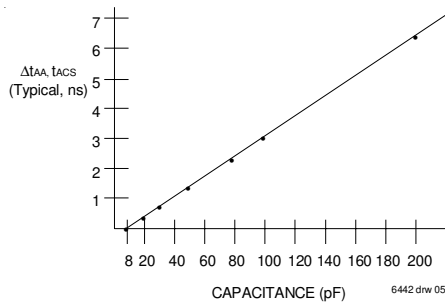

6442 drw 05

Figure 3. Output Capacitive Derating

## AC Test Conditions

|                               |                   |
|-------------------------------|-------------------|
| Input Pulse Levels            | GND to 3.0V       |
| Input Rise/Fall Times         | 1.5ns             |
| Input Timing Reference Levels | 1.5V              |
| Output Reference Levels       | 1.5V              |
| AC Test Load                  | Figures 1,2 and 3 |

6442 tbl 09

## AC Electrical Characteristics

(VDD = Min. to Max., Commercial and Industrial Temperature Ranges)

| Symbol                          | Parameter                              | 71V416S/L10 <sup>(2)</sup> |      | 71V416S/L12 |      | 71V416S/L15 |      | Unit |
|---------------------------------|--|----------------------------|------|-------------|------|-------------|------|------|
|                                 |  | Min.                       | Max. | Min.        | Max. | Min.        | Max. |      |
| <b>READ CYCLE</b>               |  |                            |      |             |      |             |      |      |
| t <sub>RC</sub>                 | Read Cycle Time                        | 10                         | —    | 12          | —    | 15          | —    | ns   |
| t <sub>AA</sub>                 | Address Access Time                    | —                          | 10   | —           | 12   | —           | 15   | ns   |
| t <sub>ACS</sub>                | Chip Select Access Time                | —                          | 10   | —           | 12   | —           | 15   | ns   |
| t <sub>CLZ</sub> <sup>(1)</sup> | Chip Select Low to Output in Low-Z     | 4                          | —    | 4           | —    | 4           | —    | ns   |
| t <sub>CHZ</sub> <sup>(1)</sup> | Chip Select High to Output in High-Z   | —                          | 5    | —           | 6    | —           | 7    | ns   |
| t <sub>OE</sub>                 | Output Enable Low to Output Valid      | —                          | 5    | —           | 6    | —           | 7    | ns   |
| t <sub>OLZ</sub> <sup>(1)</sup> | Output Enable Low to Output in Low-Z   | 0                          | —    | 0           | —    | 0           | —    | ns   |
| t <sub>OHZ</sub> <sup>(1)</sup> | Output Enable High to Output in High-Z | —                          | 5    | —           | 6    | —           | 7    | ns   |
| t <sub>OH</sub>                 | Output Hold from Address Change        | 4                          | —    | 4           | —    | 4           | —    | ns   |
| t <sub>BE</sub>                 | Byte Enable Low to Output Valid        | —                          | 5    | —           | 6    | —           | 7    | ns   |
| t <sub>BLZ</sub> <sup>(1)</sup> | Byte Enable Low to Output in Low-Z     | 0                          | —    | 0           | —    | 0           | —    | ns   |
| t <sub>BHZ</sub> <sup>(1)</sup> | Byte Enable High to Output in High-Z   | —                          | 5    | —           | 6    | —           | 7    | ns   |
| <b>WRITE CYCLE</b>              |  |                            |      |             |      |             |      |      |
| t <sub>WC</sub>                 | Write Cycle Time                       | 10                         | —    | 12          | —    | 15          | —    | ns   |
| t <sub>AW</sub>                 | Address Valid to End of Write          | 8                          | —    | 8           | —    | 10          | —    | ns   |
| t <sub>CW</sub>                 | Chip Select Low to End of Write        | 8                          | —    | 8           | —    | 10          | —    | ns   |
| t <sub>BW</sub>                 | Byte Enable Low to End of Write        | 8                          | —    | 8           | —    | 10          | —    | ns   |
| t <sub>AS</sub>                 | Address Set-up Time                    | 0                          | —    | 0           | —    | 0           | —    | ns   |
| t <sub>WR</sub>                 | Address Hold from End of Write         | 0                          | —    | 0           | —    | 0           | —    | ns   |
| t <sub>WP</sub>                 | Write Pulse Width                      | 8                          | —    | 8           | —    | 10          | —    | ns   |
| t <sub>DW</sub>                 | Data Valid to End of Write             | 5                          | —    | 6           | —    | 7           | —    | ns   |
| t <sub>DH</sub>                 | Data Hold Time                         | 0                          | —    | 0           | —    | 0           | —    | ns   |
| t <sub>OW</sub> <sup>(1)</sup>  | Write Enable High to Output in Low-Z   | 3                          | —    | 3           | —    | 3           | —    | ns   |
| t <sub>WHZ</sub> <sup>(1)</sup> | Write Enable Low to Output in High-Z   | —                          | 6    | —           | 7    | —           | 7    | ns   |

6442 tbl 10

**NOTE:**

1. This parameter is guaranteed with the AC Load (Figure 2) by device characterization, but is not production tested.
2. Low power 10ns (L10) speed 0°C to +70°C temperature range only.

### Timing Waveform of Read Cycle No. 1<sup>(1,2,3)</sup>

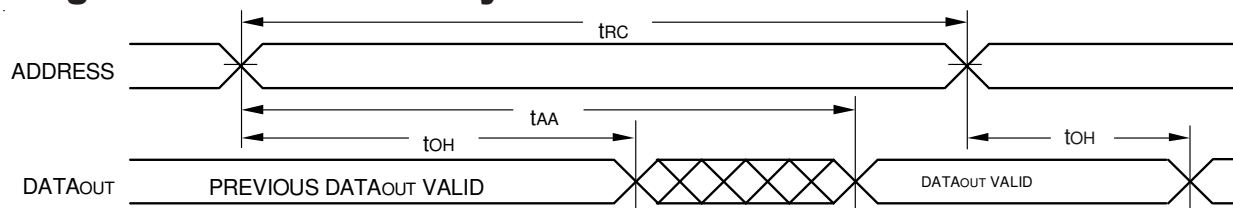

6442d06

**NOTES:**

1.  $\overline{WE}$  is HIGH for Read Cycle.
2. Device is continuously selected,  $\overline{CS}$  is LOW.
3.  $\overline{OE}$ ,  $\overline{BHE}$ , and  $\overline{BLE}$  are LOW.

## Timing Waveform of Read Cycle No. 2<sup>(1)</sup>

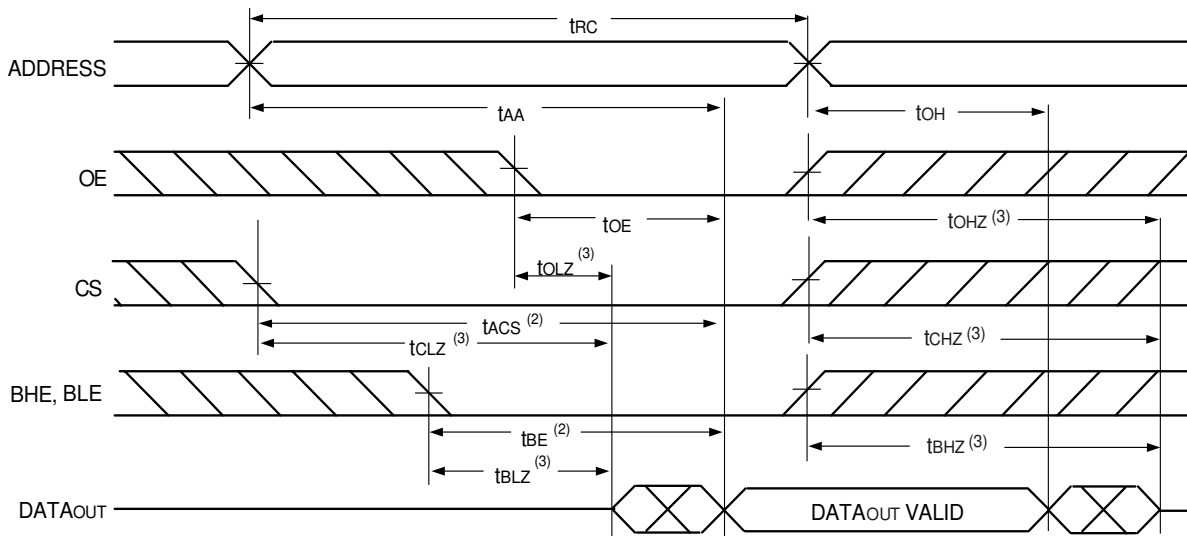

6442 drw 07

### NOTES:

1.  $\overline{WE}$  is HIGH for Read Cycle.
2. Address must be valid prior to or coincident with the later of  $\overline{CS}$ ,  $\overline{BHE}$ , or  $\overline{BLE}$  transition LOW; otherwise  $t_{AA}$  is the limiting parameter.
3. Transition is measured  $\pm 200\text{mV}$  from steady state.

## Timing Waveform of Write Cycle No. 1 ( $\overline{WE}$ Controlled Timing)<sup>(1,2,4)</sup>

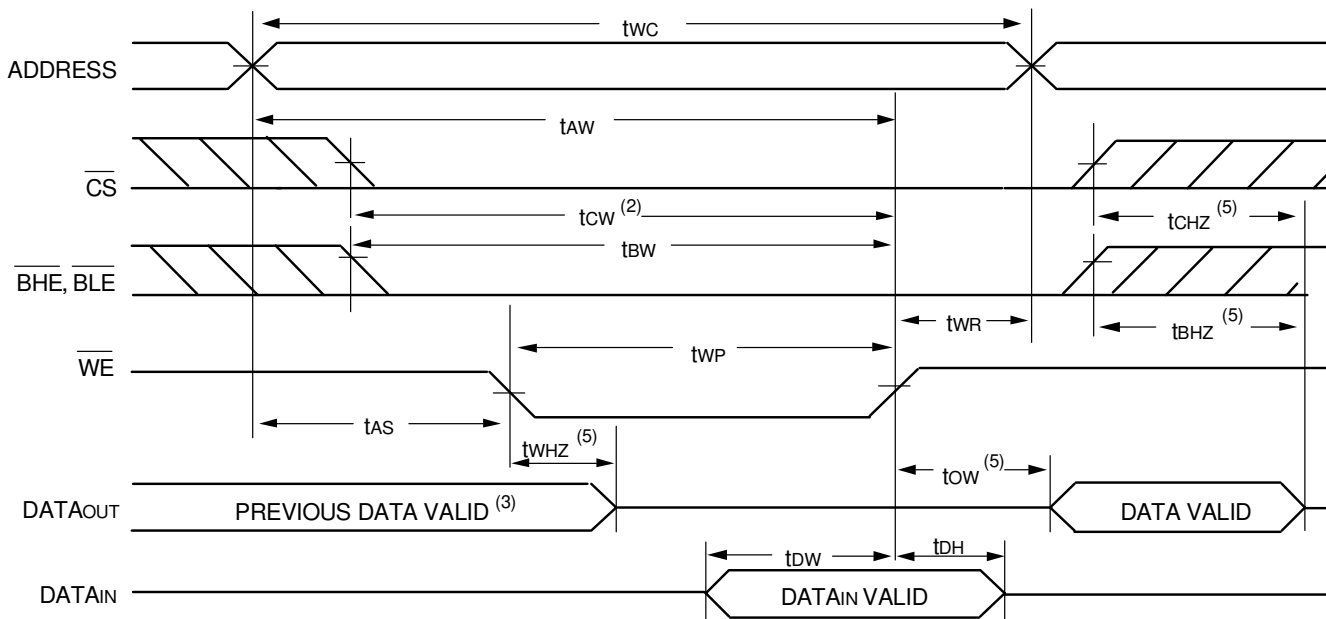

6442 drw 08

### NOTES:

1. A write occurs during the overlap of a LOW  $\overline{CS}$ , LOW  $\overline{BHE}$  or  $\overline{BLE}$ , and a LOW  $\overline{WE}$ .
2.  $\overline{OE}$  is continuously HIGH. If during a  $\overline{WE}$  controlled write cycle  $\overline{OE}$  is LOW,  $t_{WP}$  must be greater than or equal to  $t_{WHZ} + t_{BW}$  to allow the I/O drivers to turn off and data to be placed on the bus for the required  $t_{DW}$ . If  $\overline{OE}$  is HIGH during a  $\overline{WE}$  controlled write cycle, this requirement does not apply and the minimum write pulse is as short as the specified  $t_{WP}$ .
3. During this period, I/O pins are in the output state, and input signals must not be applied.
4. If the CS LOW or BHE and BLE LOW transition occurs simultaneously with or after the  $\overline{WE}$  LOW transition, the outputs remain in a high-impedance state.
5. Transition is measured  $\pm 200\text{mV}$  from steady state.

### Timing Waveform of Write Cycle No. 2 ( $\overline{CS}$ Controlled Timing)<sup>(1,3)</sup>

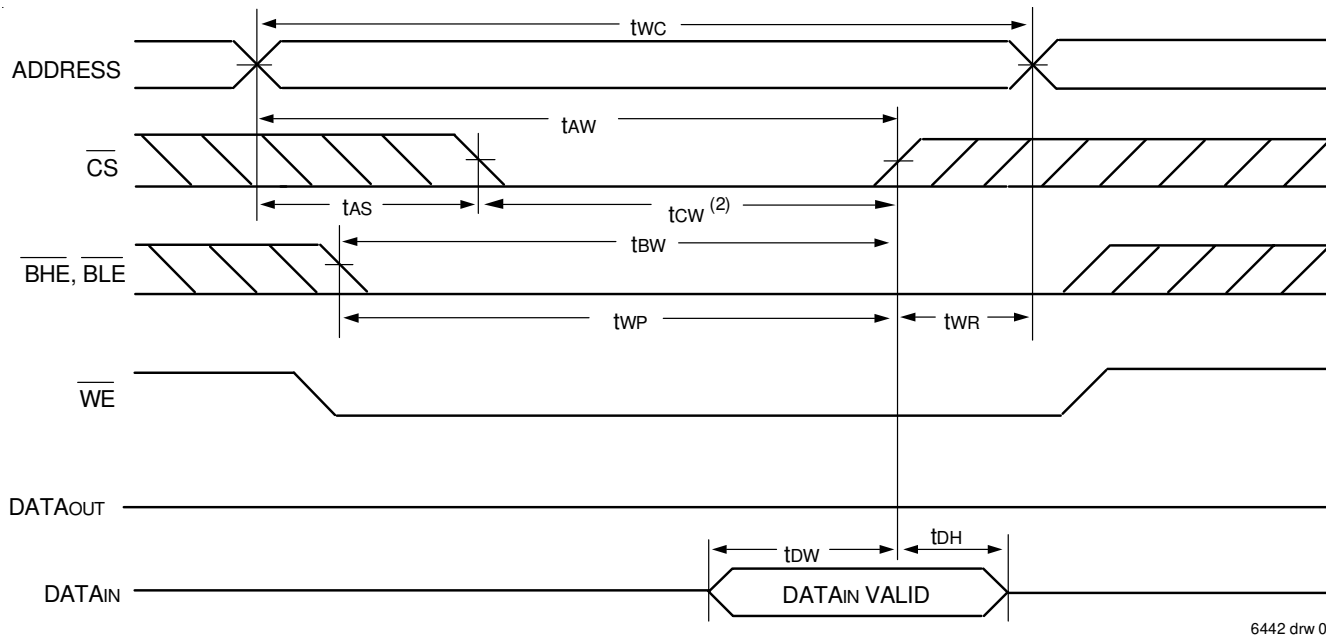

6442 drw 0

### Timing Waveform of Write Cycle No. 3 ( $\overline{BHE}$ , $\overline{BLE}$ Controlled Timing)<sup>(1,3)</sup>

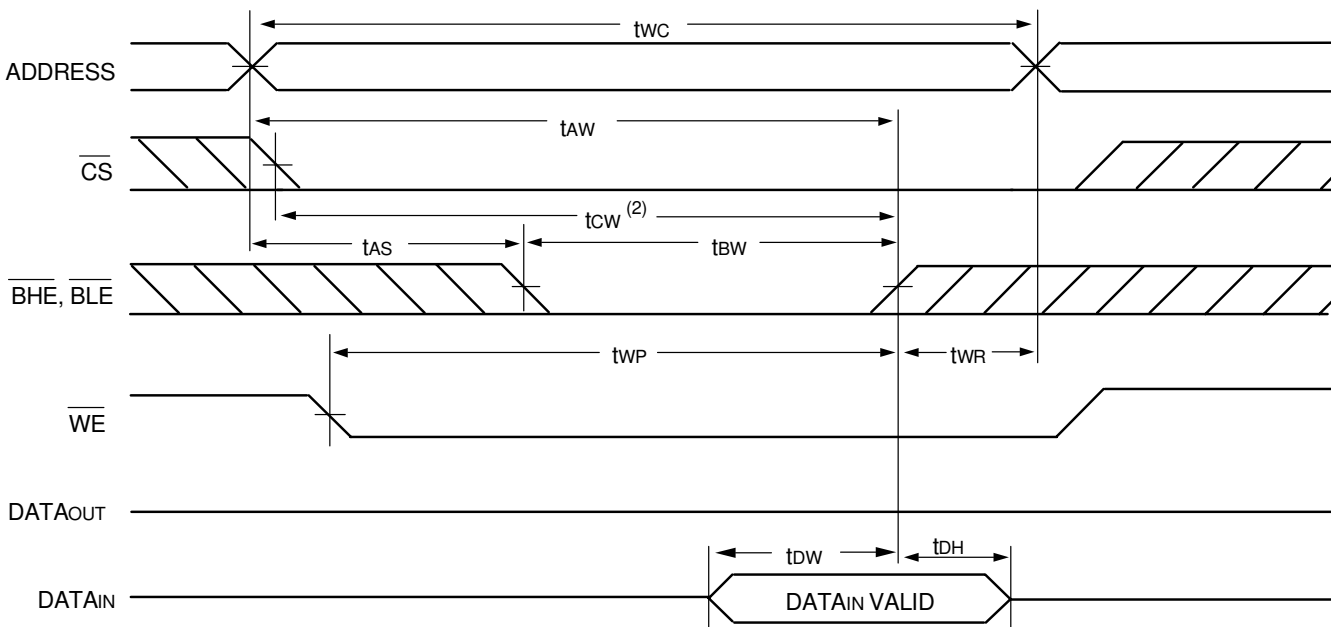

6442 drw 1

**NOTES:**

1. A write occurs during the overlap of a LOW  $\overline{CS}$ , LOW  $\overline{BHE}$  or  $\overline{BLE}$ , and a LOW  $\overline{WE}$ .
2. During this period, I/O pins are in the output state, and input signals must not be applied.
3. If the  $\overline{CS}$  LOW or  $\overline{BHE}$  and  $\overline{BLE}$  LOW transition occurs simultaneously with or after the  $\overline{WE}$  LOW transition, the outputs remain in a high-impedance state.

## Ordering Information

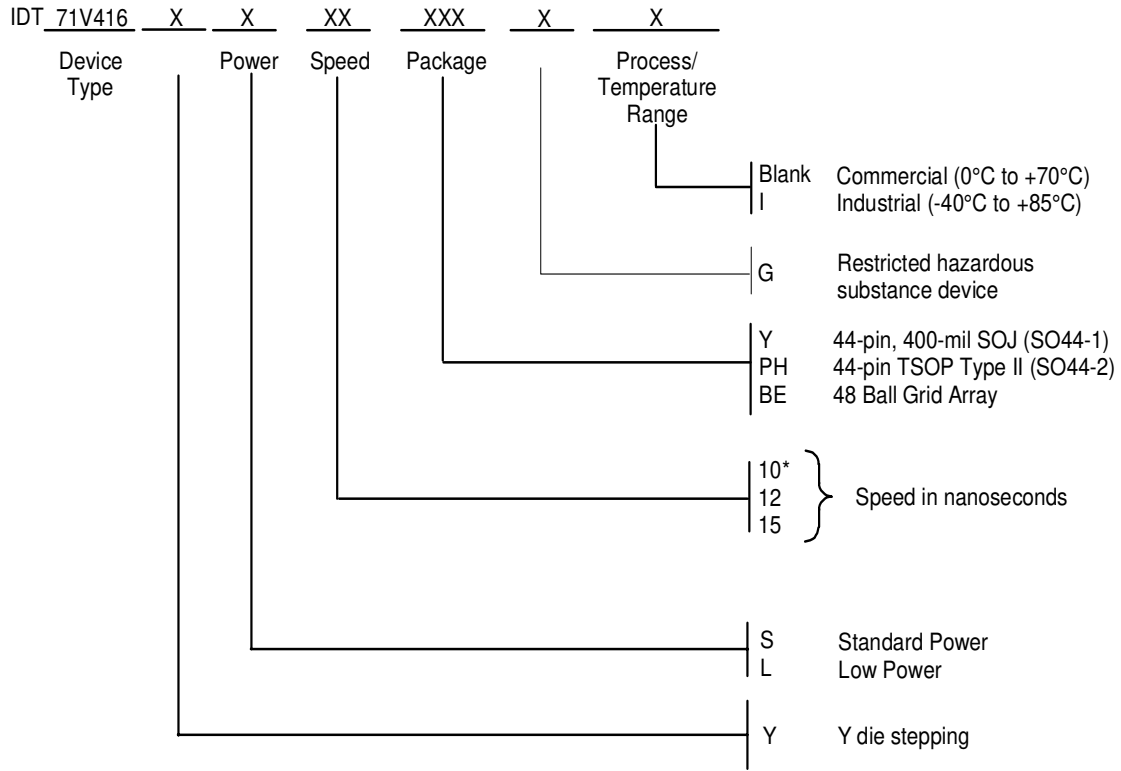

\* Commercial only for low power 10ns (L10) speed grade.

6442 drw 11a



## Datasheet Document History

|          |     |   |
|----------|-----|---|
| 10/13/03 |     | Released datasheet  |
| 07/30/04 | p.8 | Added "Restricted hazardous substance device " to ordering information. |



**CORPORATE HEADQUARTERS**  
6024 Silver Creek Valley Road  
San Jose, CA 95138

**for SALES:**  
800-345-7015 or  
408-284-8200  
fax: 408-284-2775  
[www.idt.com](http://www.idt.com)

**for Tech Support:**  
[ipchelp@idt.com](mailto:ipchelp@idt.com)  
800-345-7015

The IDT logo is a registered trademark of Integrated Device Technology, Inc.