

AMPHENOL PART NUMBER CONFIGURATION

U95-Z205-XXX1-3X1

REVISIONS			
REV	DESCRIPTION, EGN, EAR NO.	DATE	APP'D
G	Drawing Updated	OCT24/14	J.S
H	Pin Position Corrected	DEC 10/14	J.S
J	View Corrected for 8-Pec Holes With LP	JAN 20/15	J.S

CAGE & CONNECTOR CONTACT PLATING
 4 = 0.76 µm MIN. GOLD OVER 1.27-3.81 µm OF NICKEL ON MATING AREA
 0.381-1.52 µm OF MATTE TIN OVER 1.27-3.81 µm OF NICKEL ON PRESS FIT TAIL AREA.
 Ni PLATING FOR CAGE
 (RoHS COMPLIANT PER RoHS DIRECTIVE 2011/65/EU)

OPTIONAL DUST COVER
 0 = WITHOUT DUST COVER
 D = WITH DUST COVER

VENT HOLES AND EMI COVER
 0 = WITH LARGE VENT HOLES & WITH EMI COVER
 2 = WITH SMALL VENT HOLES & WITH EMI COVER
 4 = WITH RECTANGULAR VENT HOLES & WITH EMI COVER

EMI FINGERS
 3 = THROUGH THE BEZEL

OPTIONAL LIGHT PIPES
 6 = WITH LIGHT PIPE (TRIANGULAR OUTLET)
 LEFT ARROW POINTING BOTTOM PORT & RIGHT ARROW POINTING TOP PORT
 7 = WITHOUT LIGHT PIPE
 8 = WITH LIGHT PIPE (REVERSED DIRECTION)
 LEFT ARROW POINTING TOP PORT & RIGHT ARROW POINTING BOTTOM PORT

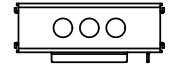
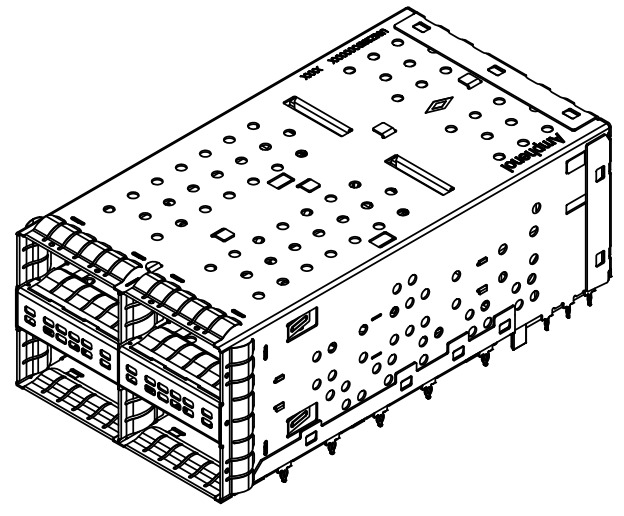

VENT HOLE FOR PART NUMBER U95-Z205-XX71-301

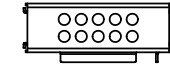

VENT HOLE FOR PART NUMBER U95-Z205-XX71-321

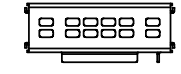

VENT HOLE FOR PART NUMBER U95-Z205-XX71-341

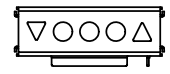

VENT HOLE FOR PART NUMBER U95-Z205-XX61-301

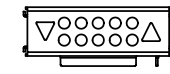

VENT HOLE FOR PART NUMBER U95-Z205-XX61-321

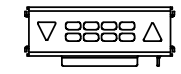

VENT HOLE FOR PART NUMBER U95-Z205-XX61-341

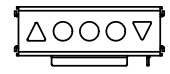

VENT HOLE FOR PART NUMBER U95-Z205-XX81-301

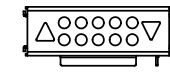

VENT HOLE FOR PART NUMBER U95-Z205-XX81-321

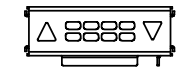

VENT HOLE FOR PART NUMBER U95-Z205-XX81-341

NOTES

- MATERIAL**
 CAGE-PRESS FIT: COPPER ALLOY, NICKEL PLATED
 CONNECTOR-PRESS FIT: PLASTIC HOUSING, FLAMMABILITY RATING UL94 V-0.
 CONTACTS: PHOSPHOR BRONZE
 PLATING OPTION: SEE AMPHENOL PART ON CONFIGURATION
 EMI FINGERS: PHOSPHOR BRONZE WITH NICKEL PLATING
 LIGHT PIPE: GELEXAN, OPTICAL GRADE
 DUST COVER (IF ORDERED) SHIPPED LOOSE



UNLESS SPECIFIED OTHERWISE	DRAWN	Alvin C	APR 18/13
PRIMARY UNITS MILLIMETERS	CHECKED	ZLJ	APR 18/13
SECONDARY MILLIMETERS	M.E. APP'D		
REFERENCE IN PARENTHESES	Q.A. APP'D		
GENERAL TOLERANCES	DWG APP'D		
1 DECIMAL PLACE ±0.25	ENG. REL. NO.		
2 DECIMAL PLACES ±0.15	REF.		
ANGULAR DEGREES ±0.5°	THIRD ANGLE PROJECTION		

Amphenol High Speed Interconnects
 A Division of Amphenol Corp. www.amphenol-highspeed.com

UltraPort QSFP+ 2X2 STACKED COMBO THROUGH BEZEL 4X25G

DWG. NO. **P-U95-Z205-XXX1-3X1** REV **J**

CODE ID NO. 03554 DWG SIZE: C SCALE: 1:1 SHEET 1 OF 4

REVISIONS			
REV	DESCRIPTION, ECG, EAR NO.	DATE	APP'D
J	SEE SHEET 1	JAN 20/ 15	JS

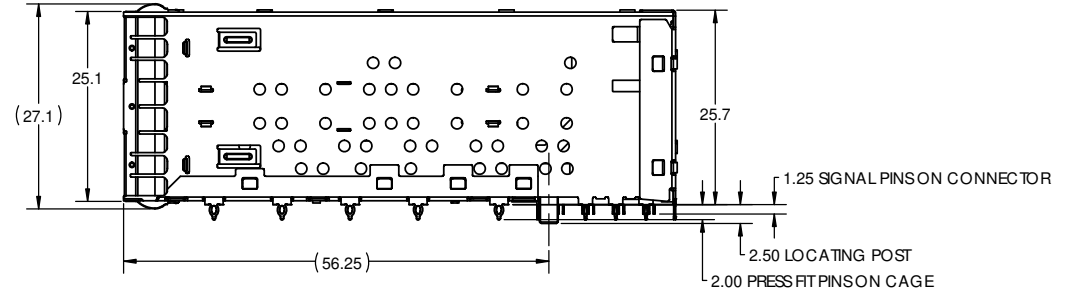
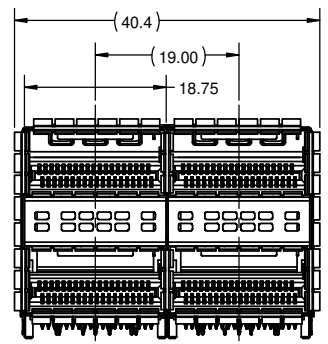
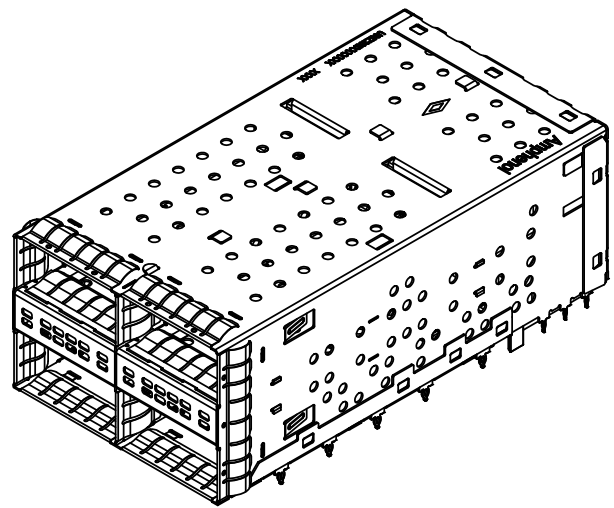
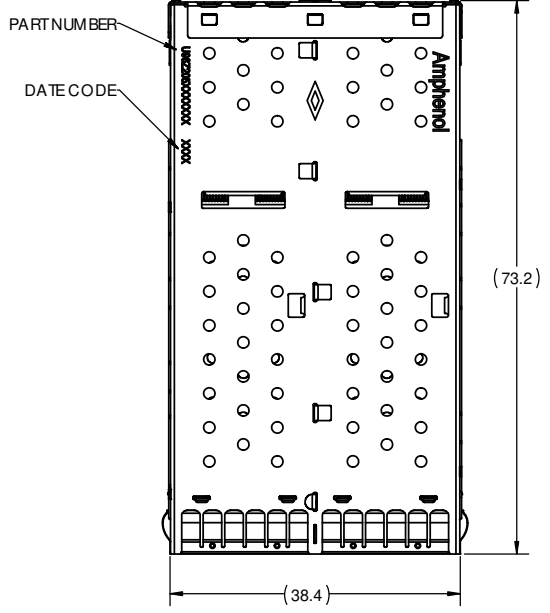

UNLESS SPECIFIED OTHERWISE	DRAWN	Alvin C	APR 18/13
PRIMARY UNITS MILLIMETERS	CHECKED	ZLJ	APR 18/13
SECONDARY MILLIMETERS	M.E. APP'D		
REFERENCE IN PARENTHESES	Q.A. APP'D		
GENERAL TOLERANCES	DWG APP'D		
1 DECIMAL PLACE ±0.25	ENG. REL. NO.		
2 DECIMAL PLACES ±0.15	REF.		
ANGULAR DEGREES ±0.5°	THIRD ANGLE PROJECTION		

Amphenol High Speed Interconnects
 A Division of Amphenol Corp. www.amphenol-highspeed.com

**UltraPort QSFP+ 2X2
 STACKED COMBO
 THROUGH BEZEL
 4X25G**

DWG. NO. **P-U95-Z205-XXX1-3X1** REV **J**

CODE ID NO. 03554 DWG SIZE: C SCALE: 1:1 SHEET 2 OF 4

THIS DOCUMENT CONTAINS PROPRIETARY INFORMATION AND SUCH INFORMATION MAY NOT BE DISCLOSED TO OTHERS FOR ANY PURPOSE OR USED FOR MANUFACTURING PURPOSES WITHOUT WRITTEN PERMISSION FROM AMPHENOL CANADA CORP.

REVISIONS			
REV	DESCRIPTION, EGN, EAR NO.	DATE	APP'D
J	SEE SHEET 1	JAN 20/ 15	JS

CROSS HATCHED REPRESENTS TRACE KEEP OUT AREA (CAGE PRESS FIT PINS)

$\varnothing 0.37 \pm 0.05$ (152)
 $\varnothing 0.10$ (M) Z X Y

$\varnothing 0.56 \pm 0.05$ (15X)
 $\varnothing 0.10$ (M) Z X Y

CROSS HATCHED REPRESENTS TRACE KEEP OUT AREA

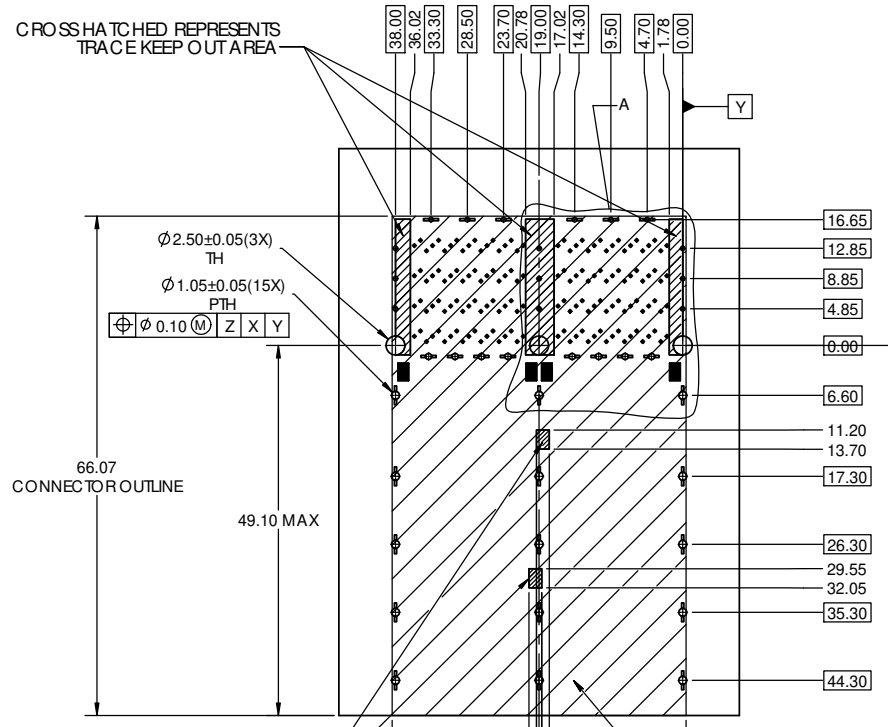

CROSS HATCHED REPRESENTS TRACE KEEP OUT AREA

CROSS HATCHED REPRESENTS COMPONENT KEEP OUT AREA (38.90)X(66.07)

RECOMMENDED PCB BOARD LAYOUT COMPONENT SIDE SHOWN

CROSS HATCHED REPRESENTS LED SOLDER PAD SEATING AREA EXTENDING VERTICALLY 0.80 MM ABOVE THE TOP OF HOST PCB

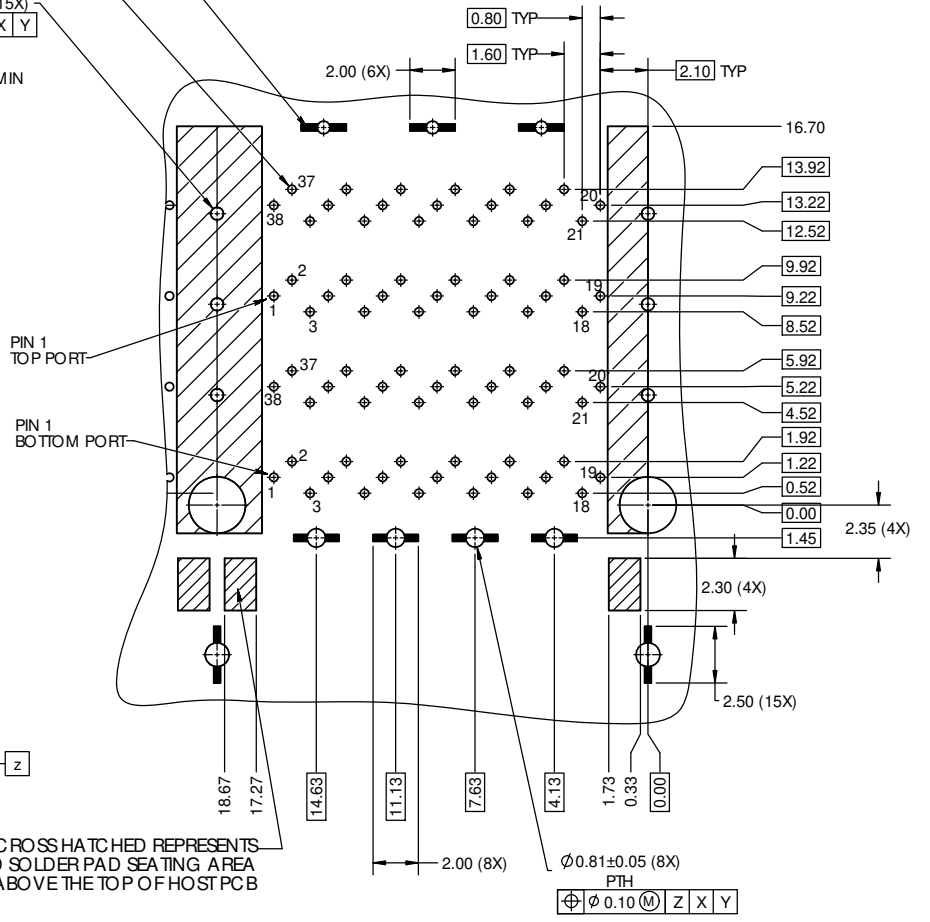

DETAIL A
SCALE 6:1



UNLESS SPECIFIED OTHERWISE	DRAWN	Alvin C	APR 18/13
PRIMARY UNITS MILLIMETERS	CHECKED	ZLJ	APR 18/13
SECONDARY MILLIMETERS	M.E. APP'D		
REFERENCE IN PARENTHESES	Q.A. APP'D		
GENERAL TOLERANCES	DWG APP'D		
1 DECIMAL PLACE ±0.25	ENG. REL. NO.		
2 DECIMAL PLACES ±0.15	REF.		
ANGULAR DEGREES ±0.5°	THIRD ANGLE PROJECTION		

Amphenol High Speed Interconnects
 A Division of Amphenol Corp. www.amphenol-highspeed.com

UltraPort QSFP+ 2X2 STACKED COMBO THROUGH BEZEL 4X25G

DWG. NO. **P-U95-Z205-XXX1-3X1** REV **J**

CODE ID NO. 03554 DWG SIZE: C SCALE: 2:1 SHEET 3 OF 4

REVISIONS			
REV	DESCRIPTION, ECG, EAR NO.	DATE	APP'D
J	SEE SHEET 1	JAN 20/ 15	JS

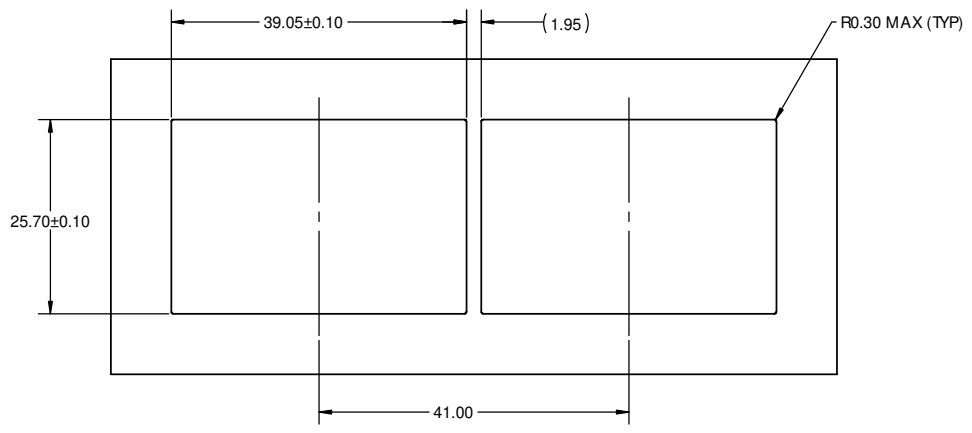
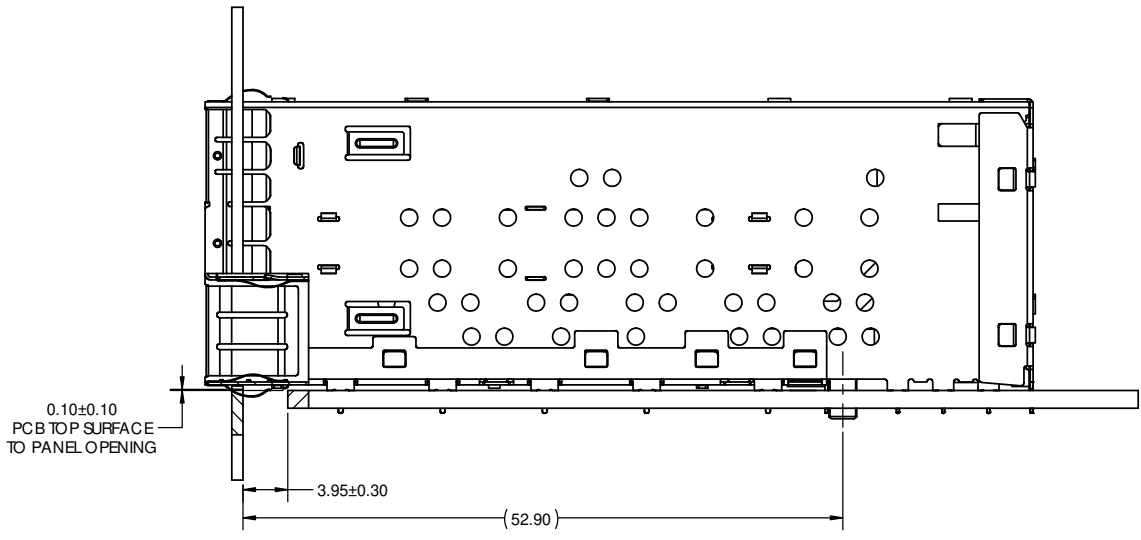

UNLESS SPECIFIED OTHERWISE	DRAWN	Alvin C	APR 18/13
PRIMARY UNITS MILLIMETERS	CHECKED	ZLJ	APR 18/13
SECONDARY MILLIMETERS	M.E. APP'D		
REFERENCE IN PARENTHESES	Q.A. APP'D		
GENERAL TOLERANCES	DWG APP'D		
1 DECIMAL PLACE ±0.25	ENG. REL. NO.		
2 DECIMAL PLACES ±0.15	REF.		
ANGULAR DEGREES ±0.5°	THIRD ANGLE PROJECTION		DO NOT SCALE DRAWING

Amphenol High Speed Interconnects
A Division of Amphenol Corp. www.amphenol-highspeed.com

**UltraPort QSFP+ 2X2
STACKED COMBO
THROUGH BEZEL
4X25G**

DWG. NO. **P-U95-Z205-XXX1-3X1** REV **J**

CODE ID NO. 03554 DWG SIZE: C SCALE: 1:1 SHEET 4 OF 4

THIS DOCUMENT CONTAINS PROPRIETARY INFORMATION AND SUCH INFORMATION MAY NOT BE DISCLOSED TO OTHERS FOR ANY PURPOSE OR USED FOR MANUFACTURING PURPOSES WITHOUT WRITTEN PERMISSION FROM AMPHENOL CANADA CORP.