

4 CHs 100mA x1/x1.5/x2 Charge Pump White LED Driver

General Description

The RT9378 is a 4 CH WLED driver with auto mode selection of x1, x1.5 and x2 mode with low dropout voltage in current sources. The RT9378 can power up to 4 white LEDs with regulated constant current for uniform intensity. Each channel (LED1 to LED4) can support up to 25mA. The part maintains highest efficiency by utilizing x1/x1.5/x2 fractional charge pump and low dropout current regulators. For the brightness control, user can easily use a PWM signal generated from GPIO to control the brightness of WLEDs.

The RT9378 is available in a WQFN-12L 2x2 package. Small 0.22μF capacitors can be used for fly capacitors. It provides the best backlighting solution with high efficiency and smallest board space for portable application.

Ordering Information

RT9378	□□
	Package Type
	QW : WQFN-12L 2x2
	Lead Plating System
	G : Green (Halogen Free and Pb Free)

Note :

Richtek products are :

- ▶ RoHS compliant and compatible with the current requirements of IPC/JEDEC J-STD-020.
- ▶ Suitable for use in SnPb or Pb-free soldering processes.

Typical Application Circuit

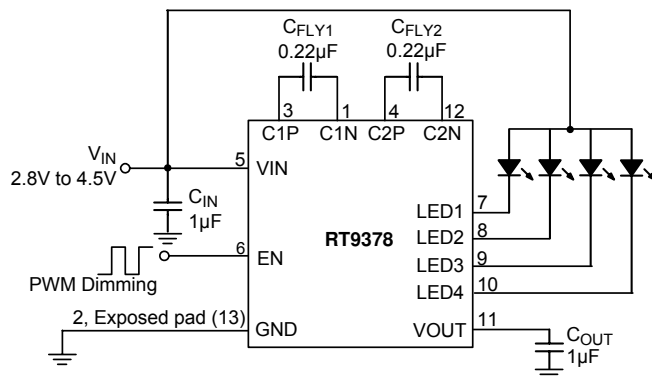

Features

- Efficiency Up to 93% Over Li-ion Battery Discharge
- Typical 85% Average Efficiency Over Li-ion Battery Discharge
- Support Up to 4 White LEDs
- Support Up to 25mA/Per Channel
- Support Up to 100mA Output Current
- PWM Brightness Control
- 60mV Typical Current Source Dropout
- 1% Typical LED Current Accuracy
- 0.7% Typical LED Current Matching
- Automatic x1/x1.5/x2 Charge Pump Mode Transition
- Low Input Noise and EMI Charge Pump
- 5V Over Voltage Protection
- Power On/Mode Transition In-rush Protection
- 1MHz Switching Frequency
- 0.4μA Low Shutdown Current
- RoHS Compliant and Halogen Free

Applications

- Camera Phone, Smart Phone
- White LED Backlighting

Pin Configurations

(TOP VIEW)

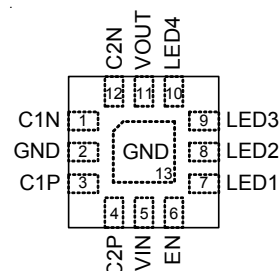

WQFN-12L 2x2

Marking Information

For marking information, contact our sales representative directly or through a Richtek distributor located in your area.

Functional Pin Description

Pin No.	Pin Name	Pin Function
1	C1N	Fly Capacitor 1 Negative Connection.
2 13 (Exposed Pad)	GND	Ground Pin. The exposed pad must be soldered to a large PCB and connected to GND for maximum power dissipation.
3	C1P	Fly Capacitor 1 Positive Connection.
4	C2P	Fly Capacitor 2 Positive Connection.
5	VIN	Power Input.
6	EN	Chip Enable (Active High).
7	LED1	Current Sink for LED1. (If not in use, connect this pin to VIN)
8	LED2	Current Sink for LED2. (If not in use, connect this pin to VIN)
9	LED3	Current Sink for LED3. (If not in use, connect this pin to VIN)
10	LED4	Current Sink for LED4. (If not in use, connect this pin to VIN)
11	VOUT	Charge Pump Output.
12	C2N	Fly Capacitor 2 Negative Connection.

Function Block Diagram

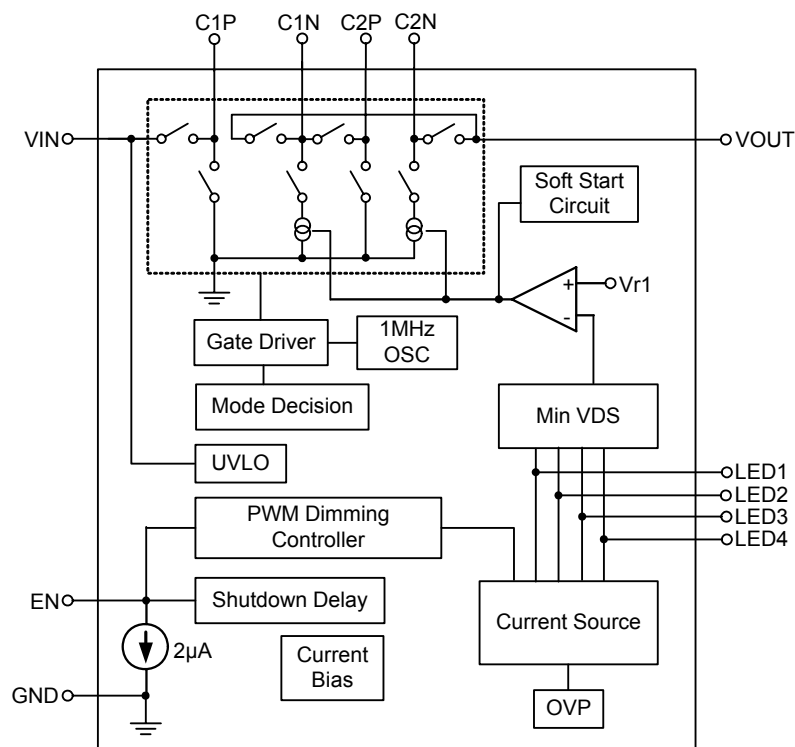

Absolute Maximum Ratings (Note 1)

- Supply Input Voltage, V_{IN} ----- -0.3V to 5V
- Output Voltage, V_{OUT} ----- -5V to 0.3V
- Power Dissipation, $P_D @ T_A = 25^\circ C$
 WQFN-12L 2x2 ----- 0.606W
- Package Thermal Resistance (Note 2)
 WQFN-12L 2x2, θ_{JA} ----- 165°C/W
- Junction Temperature ----- 150°C
- Lead Temperature (Soldering, 10 sec.) ----- 260°C
- Storage Temperature Range ----- -65°C to 150°C
- ESD Susceptibility (Note 3)
 HBM (Human Body Mode) ----- 2kV
 MM (Machine Mode) ----- 200V

Recommended Operating Conditions (Note 4)

- Junction Temperature Range ----- -40°C to 125°C
- Ambient Temperature Range ----- -40°C to 85°C

Electrical Characteristics

($V_{IN} = 3.6V$, $V_F = 3.5V$, $C_{IN} = C_{OUT} = 1\mu F$, $C_{FLY1} = C_{FLY2} = 0.22\mu F$, $I_{LED1\ to\ LED4} = 15mA$, $T_A = 25^\circ C$, unless otherwise specified)

Parameter	Symbol	Test Conditions	Min	Typ	Max	Unit
Input Power Supply						
Input Supply Voltage	V_{IN}		2.8	--	4.5	V
Under-Voltage Lockout Threshold	V_{UVLO}	V_{IN} Rising	1.8	2	2.5	V
Under-Voltage Lockout Hysteresis	ΔV_{UVLO}		--	100	--	mV
Quiescent Current	I_Q	x1 Mode	--	1	2	mA
Shutdown Current	I_{SHDN}	$V_{IN} = 4.5V$	--	0.4	2	μA
LED Current						
I_{LEDx} Accuracy		$I_{LEDx} = 25mA$	-5	0	5	%
Current Matching		$I_{LEDx} = 25mA$	-2	0	2	%
Charge Pump						
Oscillator Frequency	f_{OSC}		--	1	--	MHz
PWM Dimming Frequency		Minimum Turn On > 20 μs	1	--	4	kHz
Mode Decision						
x1 Mode to x2 Mode Transition Voltage (V_{IN} Falling)		$I_{OUT} = 100mA$, $I_{LEDx} = 25mA$	--	3.6	3.8	V
Mode Transition Hysteresis		$I_{OUT} = 100mA$, $I_{LEDx} = 25mA$	--	200	--	mV
Protection Function						
OVP		$V_{IN} - V_{OUT}$	--	5	--	V

Parameter	Symbol	Test Conditions	Min	Typ	Max	Unit
Enable						
EN Low Time for Shutdown			3	--	--	ms
EN Threshold Voltage	Logic-Low	V_{IL}	--	--	0.2	V
	Logic-High	V_{IH}	1	--	--	V
EN Pull Low Current			--	2	--	μA

Note 1. Stresses listed as the above "Absolute Maximum Ratings" may cause permanent damage to the device. These are for stress ratings. Functional operation of the device at these or any other conditions beyond those indicated in the operational sections of the specifications is not implied. Exposure to absolute maximum rating conditions for extended periods may remain possibility to affect device reliability.

Note 2. θ_{JA} is measured in the natural convection at $T_A = 25^\circ C$ on a low effective single layer thermal conductivity test board of JEDEC 51-3 thermal measurement standard. The case point of θ_{JC} is on the exposed pad for the WQFN package.

Note 3. Devices are ESD sensitive. Handling precaution is recommended.

Note 4. The device is not guaranteed to function outside its operating conditions.

Typical Operating Characteristics

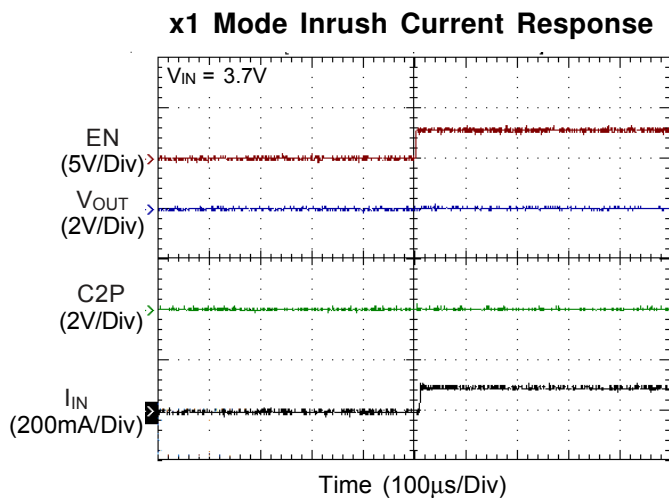
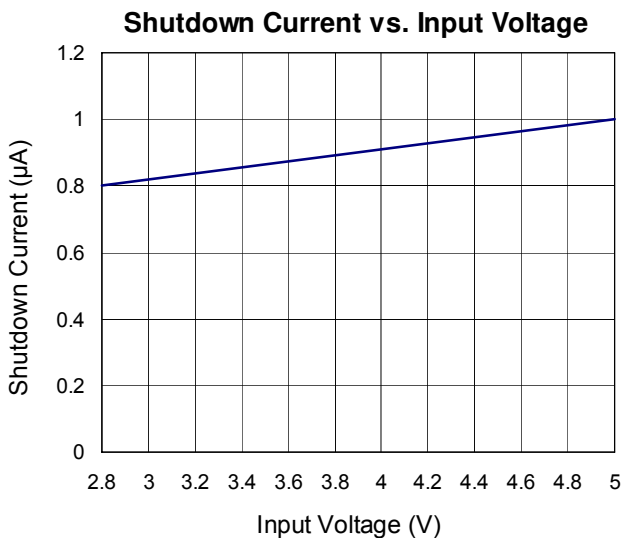
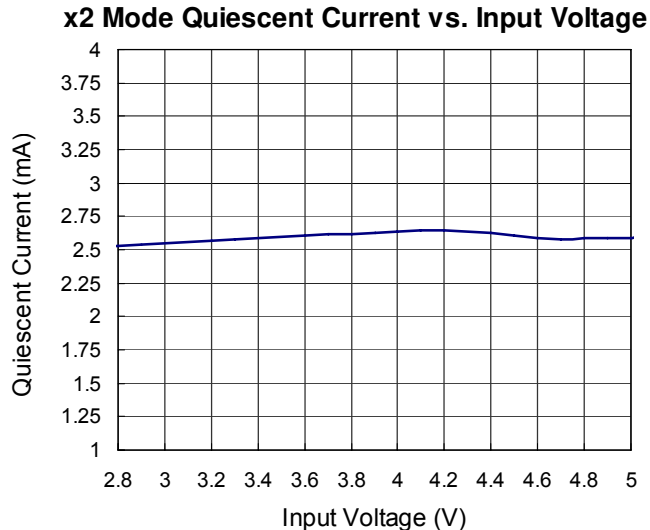
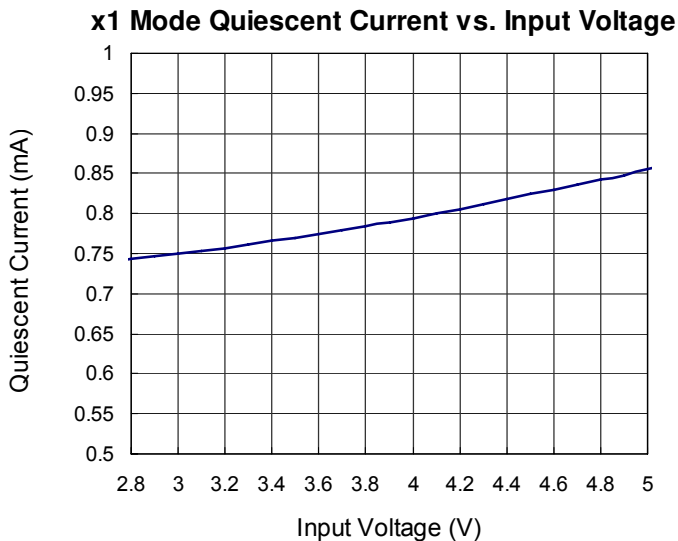
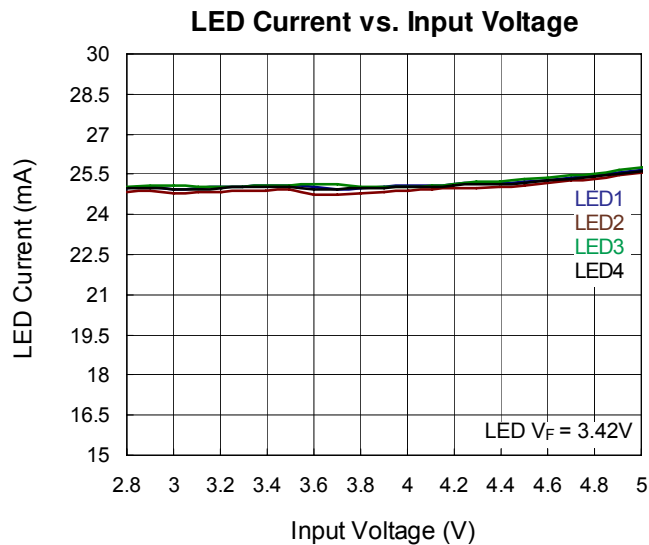
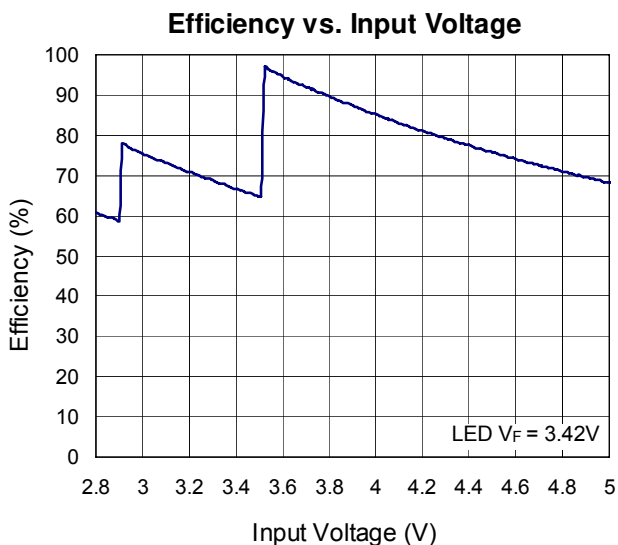

x1.5 Mode Inrush Current Response

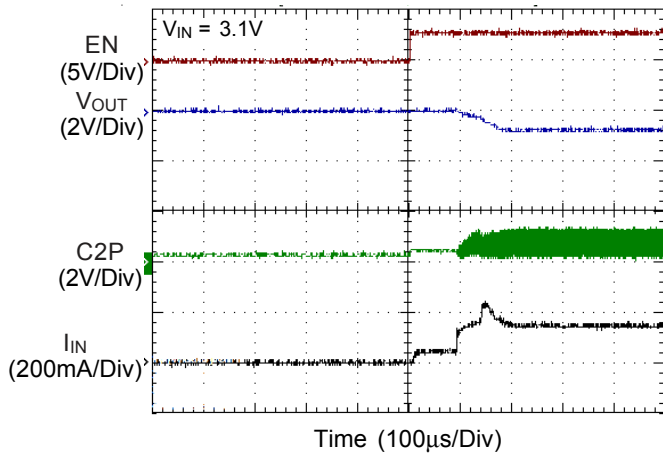

x2 Mode Inrush Current Response

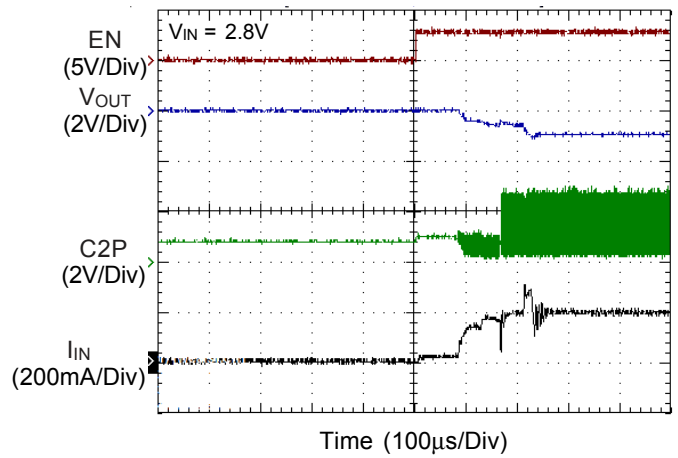

x1 Mode Dimming Operation

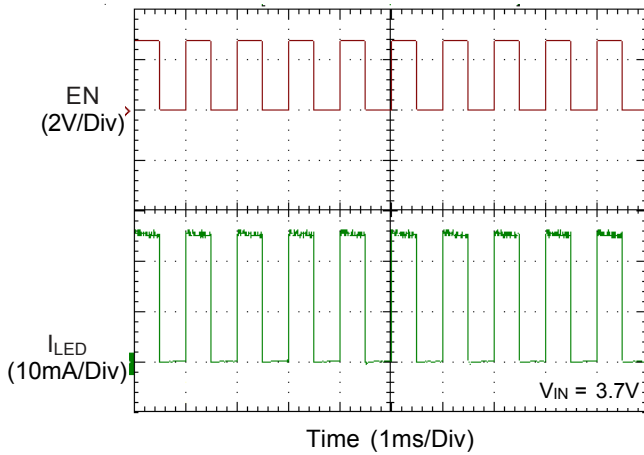

Ripple & Spike

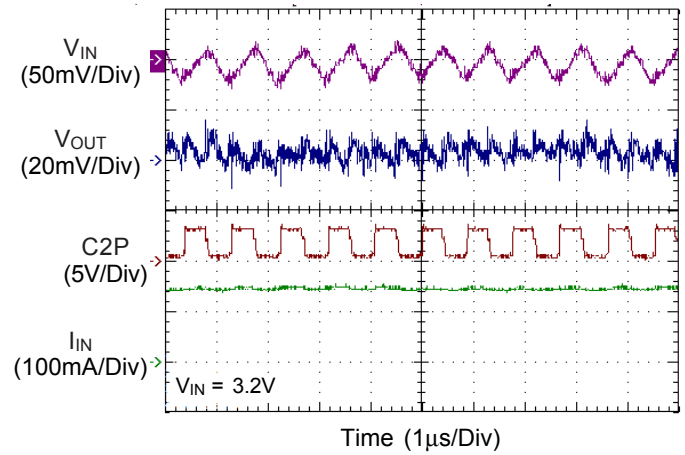

Applications Information

The RT9378 uses a fractional switched capacitor charge pump to power up to four white LEDs with a programmable current for uniform intensity. The part integrates current sources and automatic mode selection charge pump. It maintains the high efficiency by utilizing an x1/x1.5/x2 fractional charge pump and current sources. The small equivalent x1 mode open loop resistance and ultra-low dropout voltage of current source extend the operating time of x1 mode and optimize the efficiency in white LED applications.

Input UVLO

The input operating voltage range of the LED driver is from 2.8V to 4.5V. An input capacitor at the VIN pin could reduce ripple voltage. It is recommended to use a ceramic 1 μ F or larger capacitance as the input capacitor. This RT9378 provides an under voltage lockout (UVLO) function to prevent it from unstable issue when startup. The UVLO threshold of input rising voltage is set at 2V typically with a hysteresis of 100mV.

Soft Start

The charge pump employs a soft-start feature to limit the inrush current. The soft-start circuit prevents the excessive inrush current and input voltage droop. The soft-start clamps the input current over a typical period of 50 μ s.

Mode Decision

The RT9378 uses a smart mode selection method to decide the working mode for optimizing the efficiency. Mode decision circuit senses the output and LED voltage for up/down selection. The RT9378 automatically switches to x1.5 or x2 mode whenever the dropout condition is detected from the current source and returns to x1 mode whenever the dropout condition releases.

LED connection

The RT9378 supports up to 4 white LEDs. The 4 LEDs are connected from VIN to pin7, 8, 9, and 10 respectively. If the LED is not used, the LED pin should be connected to VIN directly.

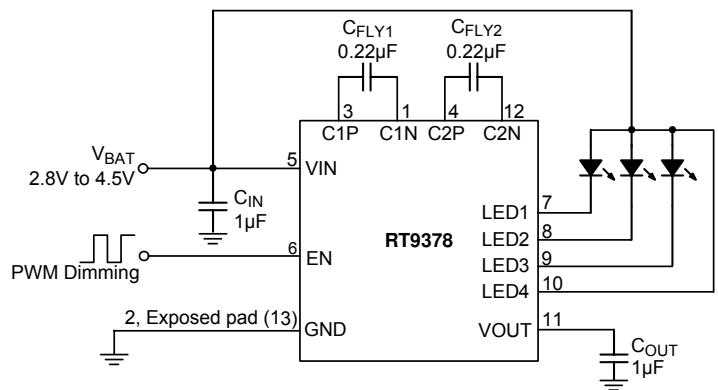

Figure 1. Application Circuit for One Channel Disabled

Capacitor Selection

To get the better performance of the RT9378, the selection of peripherally appropriate capacitor and value is very important. These capacitors determine some parameters such as input/output ripple voltage, power efficiency and maximum supply current by charge pump. To reduce the input and output ripple effectively, the low ESR ceramic capacitors are recommended. For LED driver applications, the input voltage ripple is more important than output ripple. Input ripple is controlled by input capacitor CIN, increasing the value of input capacitance can further reduce the ripple. Practically, the input voltage ripple depends on the power supply impedance. The flying capacitor CFLY1 and CFLY2 determine the supply current capability of the charge pump to influence the overall efficiency of the system. The lower value will improve efficiency. However, it will limit the LED's current at low input voltage. For 4 X25mA load over the entire input range of 2.8V to 4.5V, it is recommended to use a 0.22 μ F ceramic capacitor on the flying capacitor CFLY1 and CFLY2.

Brightness Control

The RT9378 implements a PWM dimming method to control the brightness of white LEDs. When an external PWM signal is connected to the EN pin, brightness of white LED is adjusted by the duty cycle. The suggest PWM dimming frequency is 1kHz to 4kHz and the PWM minimum turn on time must be >20 μ s.

Thermal Considerations

For continuous operation, do not exceed absolute maximum operation junction temperature. The maximum power dissipation depends on the thermal resistance of IC package, PCB layout, the rate of surroundings airflow and temperature difference between junction to ambient. The maximum power dissipation can be calculated by following formula :

$$P_{D(MAX)} = (T_{J(MAX)} - T_A) / \theta_{JA}$$

Where $T_{J(MAX)}$ is the maximum operation junction temperature, T_A is the ambient temperature and the θ_{JA} is the junction to ambient thermal resistance.

For recommended operating conditions specification of RT9378, The maximum junction temperature is 125°C. The junction to ambient thermal resistance θ_{JA} is layout dependent. For WQFN-12L 2x2 packages, the thermal resistance θ_{JA} is 165°C/W on the standard JEDEC 51-3 single layer thermal test board. The maximum power dissipation at $T_A = 25^\circ\text{C}$ can be calculated by following formula :

$$P_{D(MAX)} = (125^\circ\text{C} - 25^\circ\text{C}) / (165^\circ\text{C/W}) = 0.606\text{W for WQFN-12L 2x2 packages}$$

The maximum power dissipation depends on operating ambient temperature for fixed $T_{J(MAX)}$ and thermal resistance θ_{JA} . For RT9378 packages, the Figure 2 of derating curves allows the designer to see the effect of rising ambient temperature on the maximum power allowed.

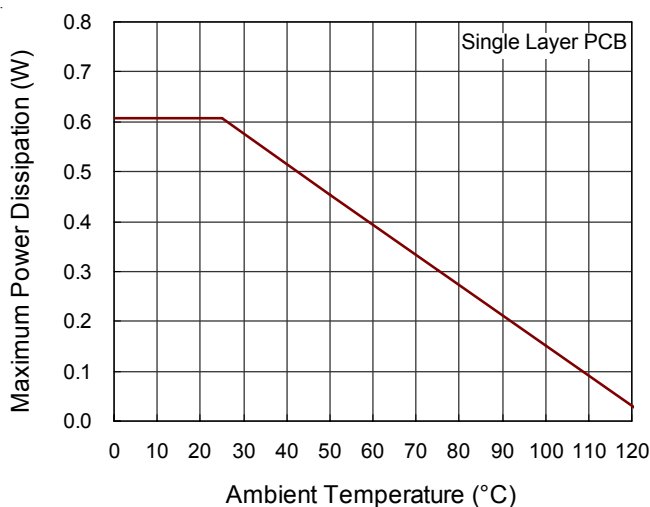

Figure 2. Derating Curves for RT9378 Packages

Layout Considerations

The RT9378 is a high-frequency switched-capacitor converter. Careful PCB layout is necessary. For best performance, place all peripheral components as close to the IC as possible. Place CIN, COUT, CFLY1, and CFLY2 near to VIN, VOUT, CP1, CN1, CP2, CN2, and GND pin respectively. A short connection is highly recommended. The following guidelines should be strictly followed when designing a PCB layout for the RT9378.

- ▶ The exposed GND pad must be soldered to a large ground plane for heat sinking and noise prevention. The throughhole vias located at the exposed pad is connected to ground plane of internal layer.
- ▶ VIN traces should be wide enough to minimize inductance and handle the high currents. The trace running from battery to chip should be placed carefully and shielded strictly.
- ▶ Input and output capacitors must be placed close to the part. The connection between pins and capacitor pads should be copper traces without any through-hole via connection.
- ▶ The flying capacitors must be placed close to the part. The traces running from the pins to the capacitor pads should be as wide as possible. Long traces will also produce large noise radiation caused by the large dv/dt on these pins. Short trace is recommended.
- ▶ All the traces of LED and VIN running from pins to LCM module should be shielded and isolated by ground plane. The shielding prevents the interference of high frequency noise coupled from the charge pump.
- ▶ Output capacitor must be placed between GND and VOUT to reduce noise coupling from charge pump to LEDs.

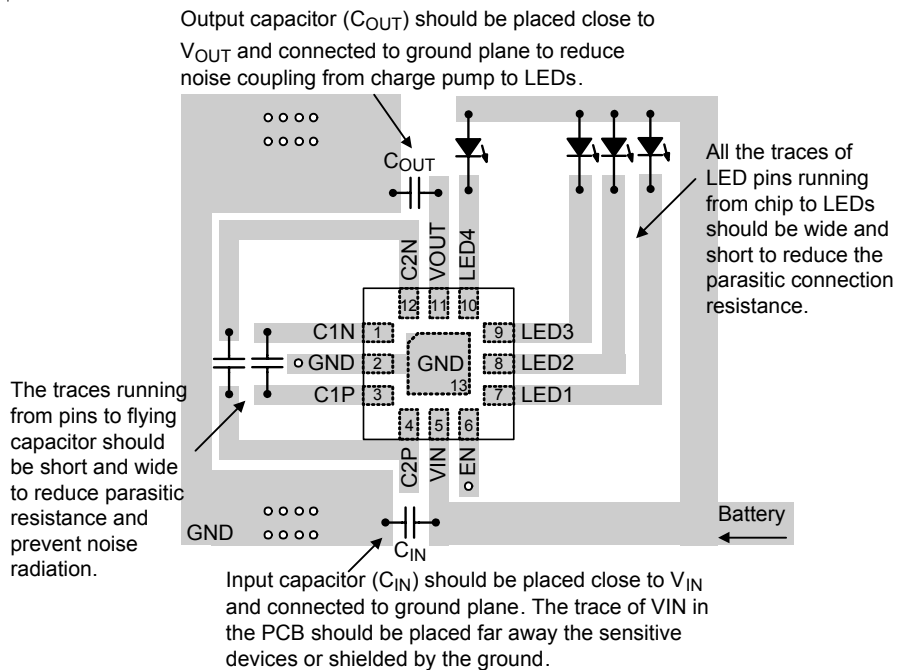
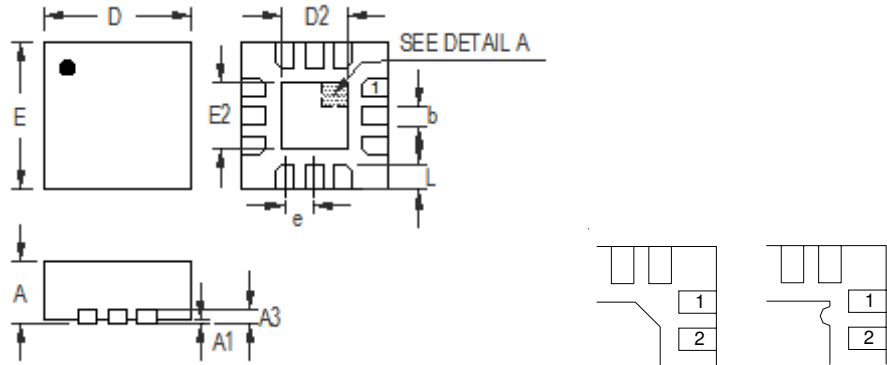

Figure 2. PCB Layout for RT9378

Outline Dimension



DETAIL A

Pin #1 ID and Tie Bar Mark Options

Note : The configuration of the Pin #1 identifier is optional, but must be located within the zone indicated.

Symbol	Dimensions In Millimeters		Dimensions In Inches	
	Min	Max	Min	Max
A	0.700	0.800	0.028	0.031
A1	0.000	0.050	0.000	0.002
A3	0.175	0.250	0.007	0.010
b	0.150	0.250	0.006	0.010
D	1.900	2.100	0.075	0.083
E	1.900	2.100	0.075	0.083
e	0.400		0.016	
D2	0.850	0.950	0.033	0.037
E2	0.850	0.950	0.033	0.037
L	0.250	0.350	0.010	0.014

W-Type 12L QFN 2x2 Package

Richtek Technology Corporation

14F, No. 8, Tai Yuen 1st Street, Chupei City
 Hsinchu, Taiwan, R.O.C.
 Tel: (8863)5526789

Richtek products are sold by description only. Richtek reserves the right to change the circuitry and/or specifications without notice at any time. Customers should obtain the latest relevant information and data sheets before placing orders and should verify that such information is current and complete. Richtek cannot assume responsibility for use of any circuitry other than circuitry entirely embodied in a Richtek product. Information furnished by Richtek is believed to be accurate and reliable. However, no responsibility is assumed by Richtek or its subsidiaries for its use; nor for any infringements of patents or other rights of third parties which may result from its use. No license is granted by implication or otherwise under any patent or patent rights of Richtek or its subsidiaries.