

RECEIVER-612-2-SC-LEAN-WP

The 6x12x2 mm LEAN-WP is an advanced miniature receiver of rectangular shape, specifically designed for waterproof applications in flat phones where wide-band quality sound and hearing-aid compatibility are required.

All materials used on the top surface of the speaker are tested to be water resistant.

100% leak measurement guarantees IPx8 waterproof compliance.

In addition to waterproof compliance this component provides the same performance as the standard LEAN receiver component (available under part number 2403 260 00051).

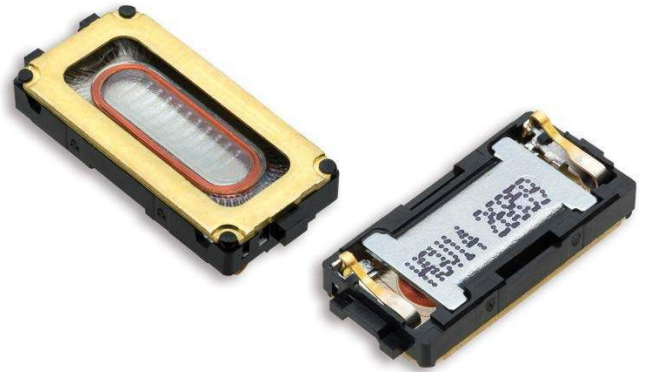

Features:

- IPx8 waterproof tested in 1.5m for 30min.
- Waterproof compliance 100% tested for each single speaker device
- Designed for 3GPP wide band audio
- Hearing Aid Compatibility (HAC) according to ANSI C3.19-2006
- Compound membrane for minimum THD, Q-factor and tumbling, and high power handling capacity
- Fully-automated manufacturing
- Pre-loaded springs for mechanical robustness and easy handling
- 100% in-line measurement of specified acoustical and electrical parameters

2403 260 00106

Contents

1. Theory of operation.....	3
2. Mechanical layout and dimensions.....	4
2.1. Main dimensions	4
2.2. PWB layout & electric polarity	5
2.3. Spring force	6
2.4. Force on component	7
2.5. Part marking / labeling	8
2.6. Material list.....	9
2.7. Water/gas tightness	9
3. Electrical and Acoustical specifications.....	10
3.1. Frequency response	10
3.2. Electro-Acoustic parameters	11
3.3. Power handling.....	11
3.4. Measurement setup	12
3.5. Measured parameters.....	12
3.6. Measurement adapter	13
4. Environmental conditions	14
4.1. Storage.....	14
4.2. Transportation.....	14
4.3. Functionality.....	14
5. Environmental tests	15
5.1. Qualification tests.....	15
5.2. Reliability tests	15
5.3. Test sequence sample size	15
5.4. Period of shelf-life	15
5.5. Testing procedures.....	15
6. Change history.....	20
7. Disclaimer	20



2403 260 00106

1. Theory of operation

RECEIVER-612-2-SC-LEAN-WP is an electrodynamic transducer, designed to translate electrical analog signals into acoustic waves. The input signal is fed into a coil which is exposed to a permanent magnetic field and where a membrane is attached to. Through the principle of the resulting electromagnetic force, the membrane is moved according to the contents of the input signal and thus emitting sound by the air shifted.

2403 260 00106

2. Mechanical layout and dimensions

2.1. Main dimensions

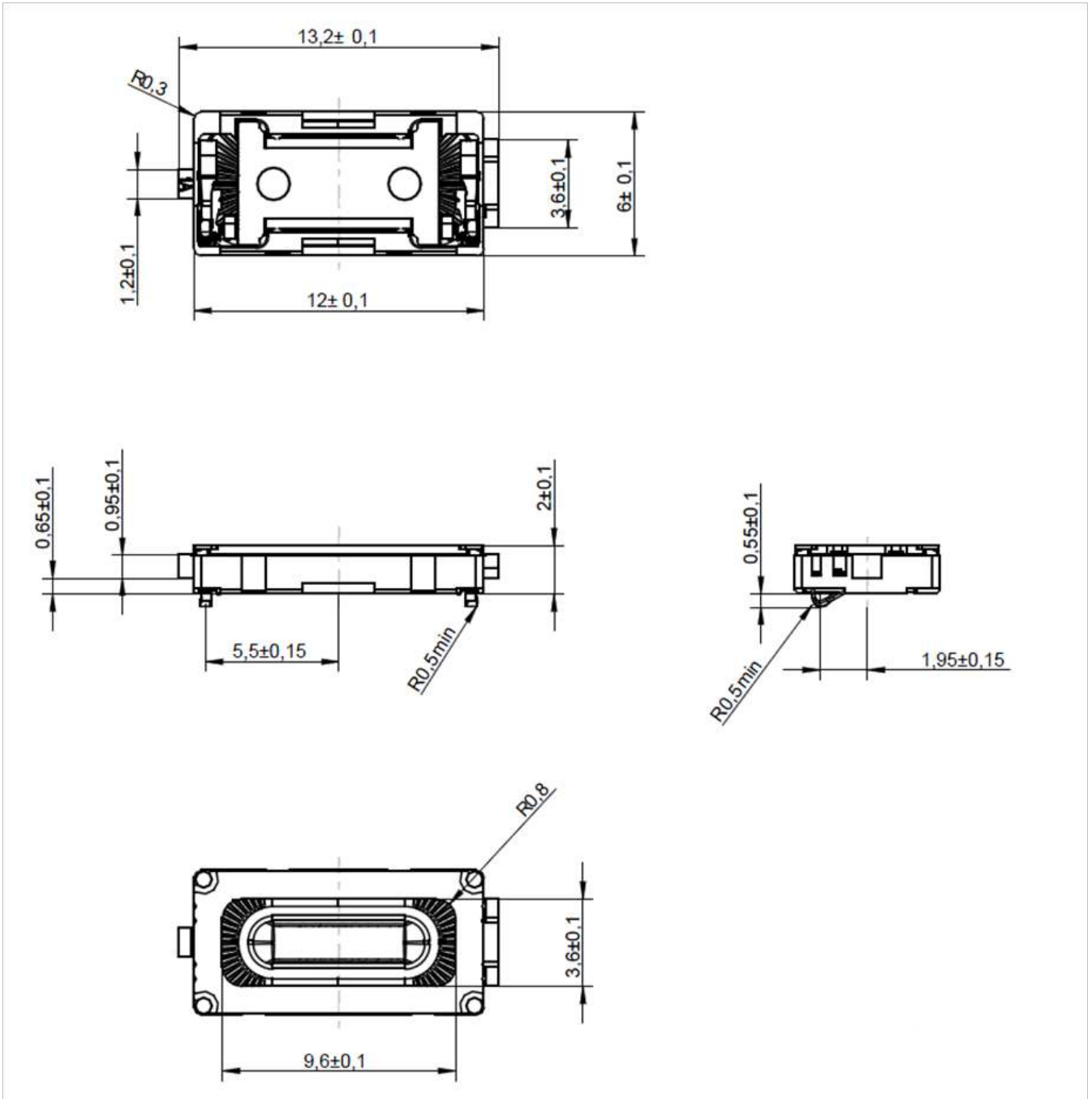

2403 260 00106

2.2. PWB layout & electric polarity

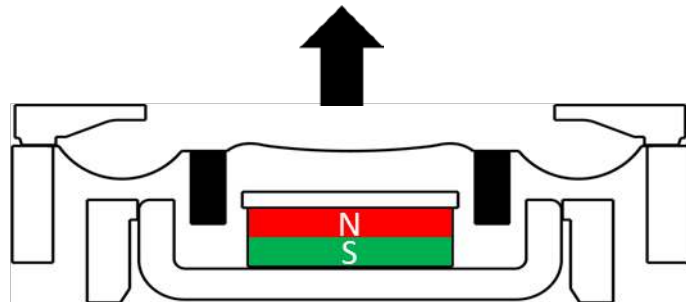
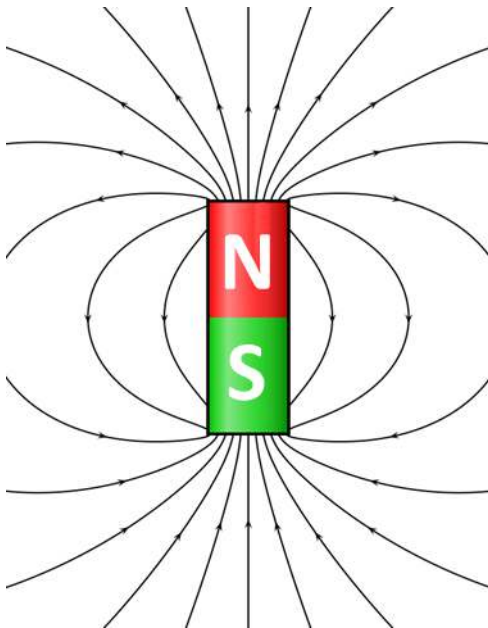
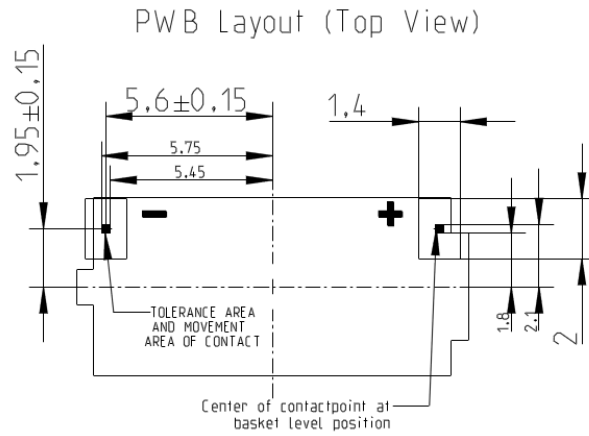

Positive voltage on pin +
 Moves the membrane in direction of arrow

2403 260 00106

2.3. Spring force

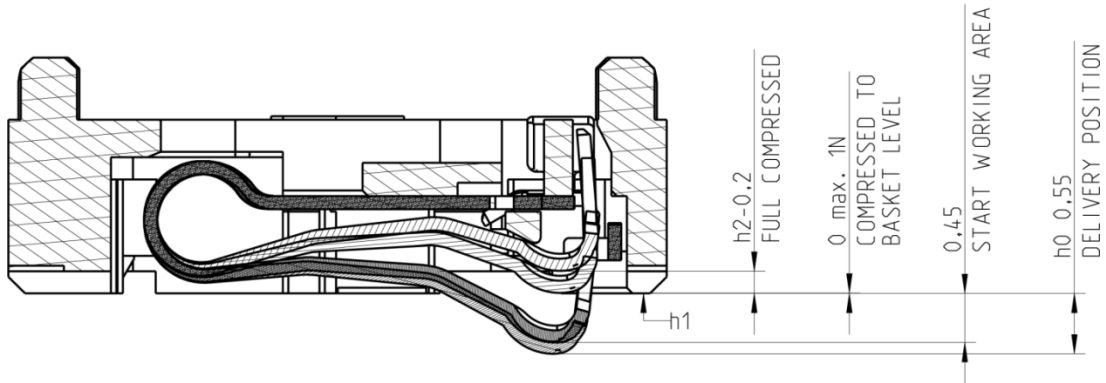

RA 6x12x2 springforces

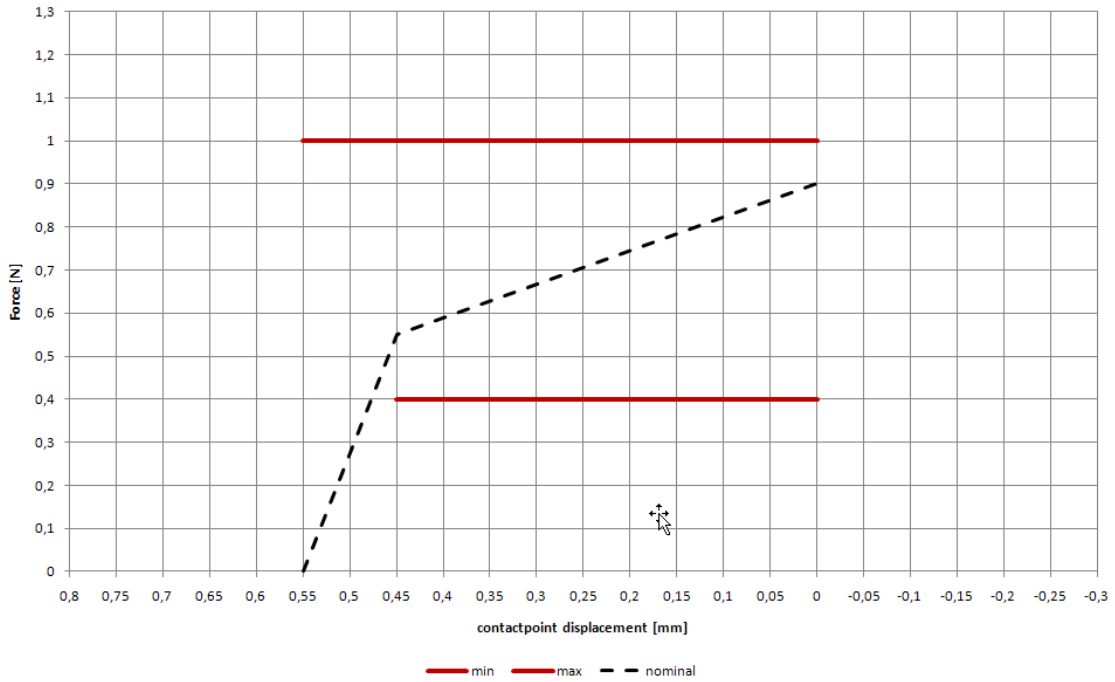

SPRING FORCE TABLE		
Force at basket level	0 mm	max 1.0 N
Force at start working position	0.45 mm	min 0.4 N
uncompressed (delivery position)	0.55 +/- 0.15 mm	0 N
Force at PPP level (full compressed)	-0.2 mm	max 1.0 N

2403 260 00106

2.4. Force on component

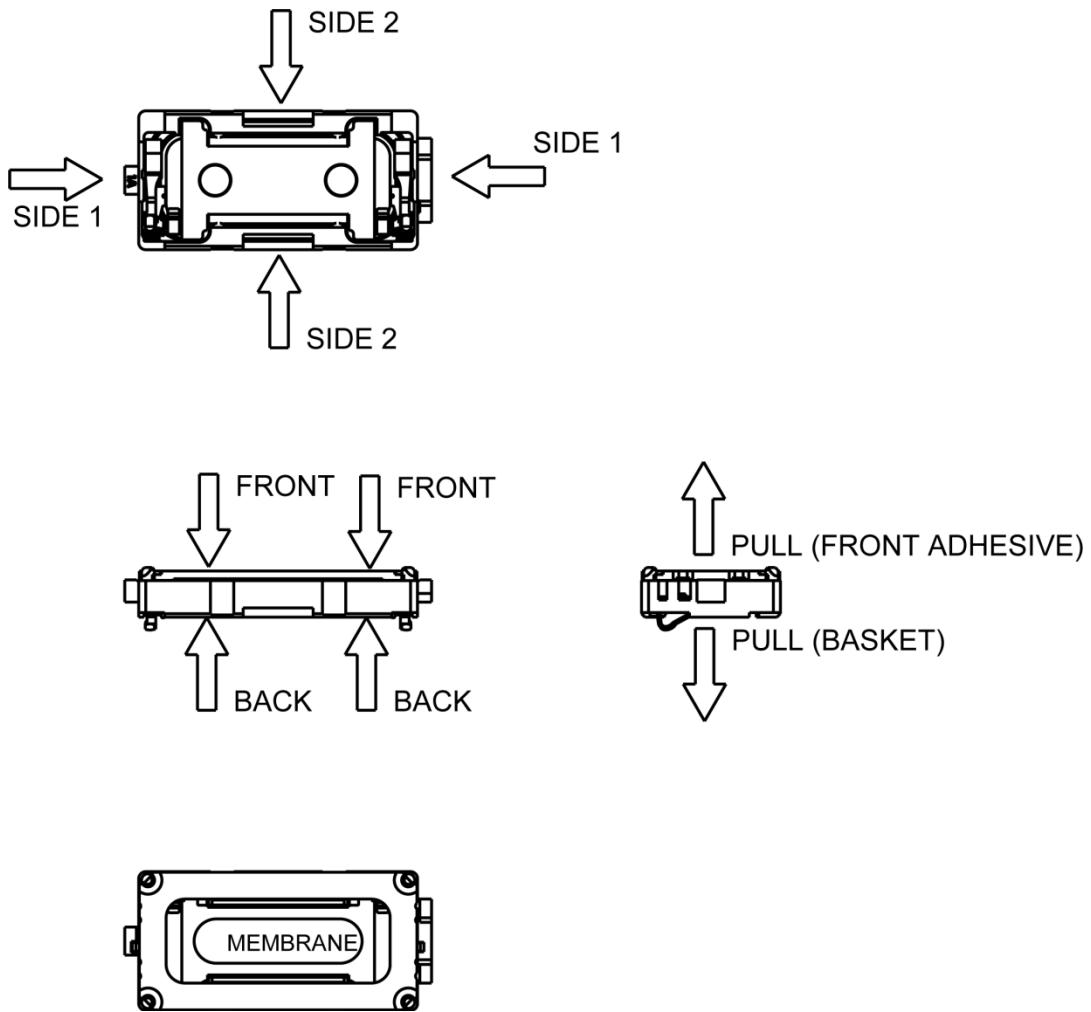

FORCES ON DIFFERENT STATE OF COMPONENT			
STATE	MIN. SURFACE OF PREASURE [mm ²]	MAX PERMANENT FORCE [N]	MAX HANDLING FORCE [N]
FROM FRONT TO BACK	-	10	15
FROM SIDE 1 TO SIDE 1	3	10	15
FROM SIDE 2 TO SIDE 2	10	10	15
POT	-	0	10
MEMBRANE	-	0	0
PULL OF FORCE (Cover)	-	0	5

2403 260 00106

2.5. Part marking / labeling

The samples have a serial number on bottom (pot) side

VARIANT A - Laser Printing

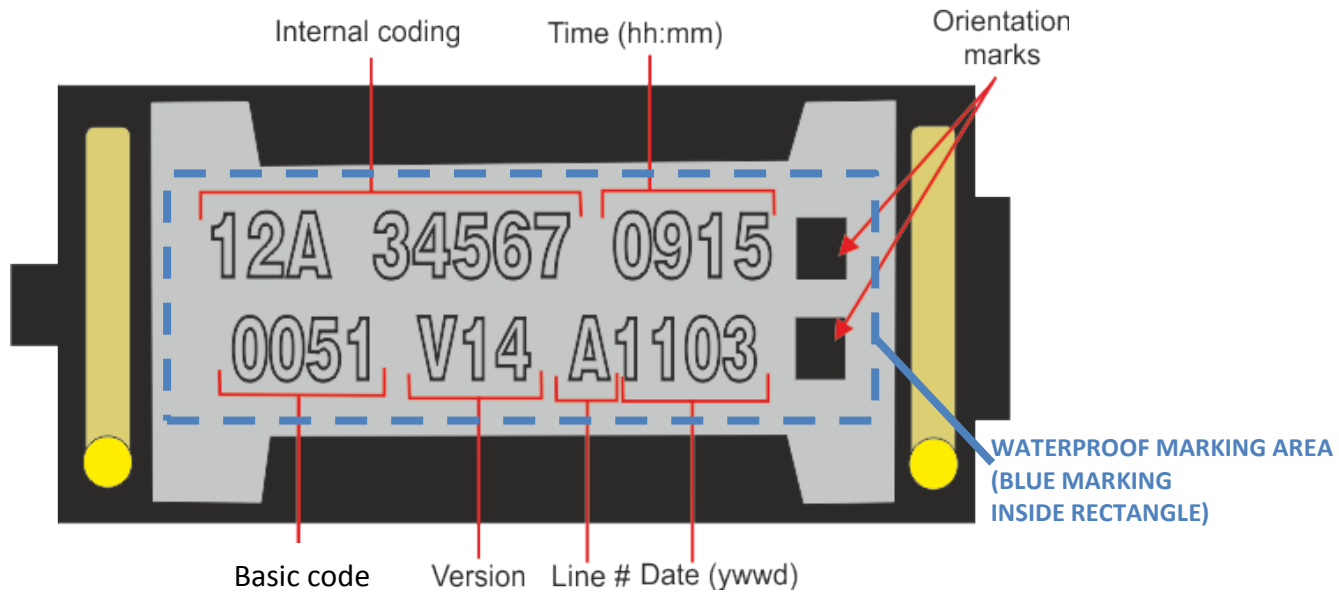

VARIANT B - Inkjet Printing

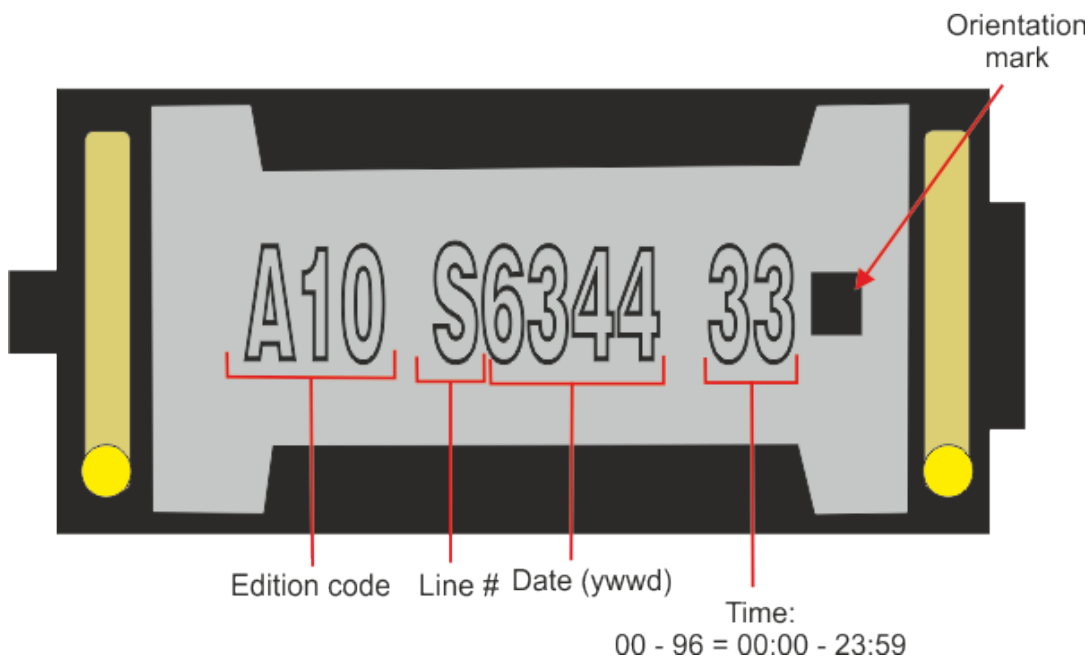

2403 260 00106

2.6. Material list

- | | |
|--------------------------|------------------------------|
| 1. Material of basket: | Polycarbonate (Halogen free) |
| 2. Material of membrane: | Polyarylate-Compound |
| 3. Material of pot: | soft magnetic Iron |
| 4. Material of magnet: | Nd Fe B |
| 5. Material of contact | CrNi Steel gold plated |
| 6. Material of cover: | Brass |
| 7. Dimensions (in mm): | 6x12x2 |
| 8. Mass: | 0.35 g |

2.7. Water/gas tightness

The products are 100% tested for leaks between cover and membrane.

Method: Differential pressure measurement

Down force on cover: > 5N

Allowed leakage < 3 cm³/minute.

2403 260 00106

3. Electrical and Acoustical specifications

3.1. Frequency response

Typical frequency response measured on baffle according to chapter 3.4
(distance $d = 1\text{cm}$, $p = 10\text{mW}$, without back cavity)

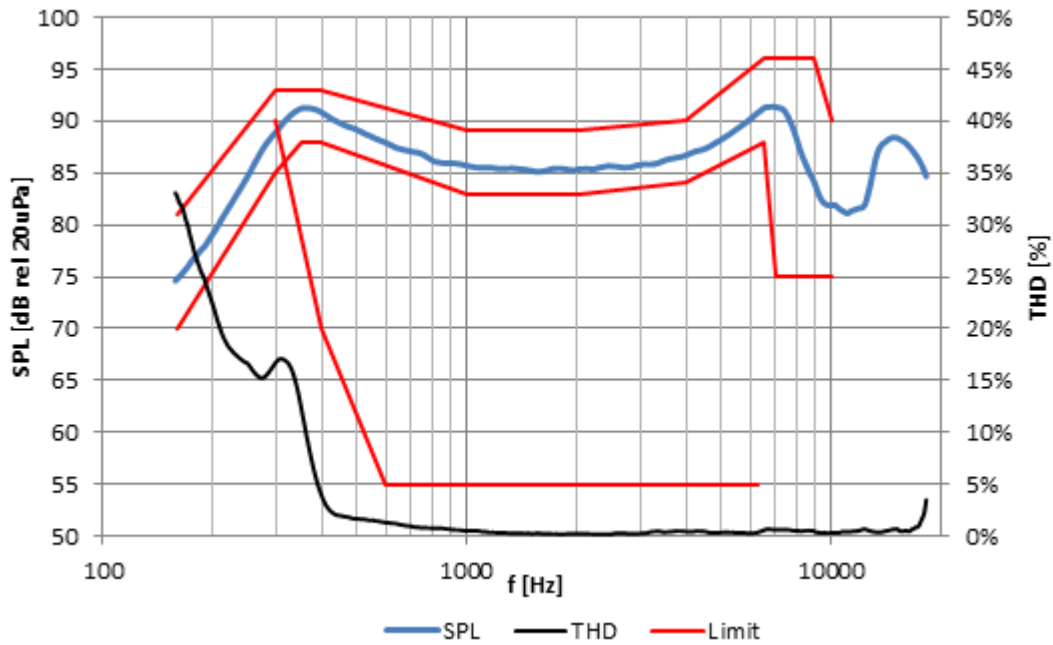

Tolerance window				
f [Hz]	SPL		THD	
	lower limit [dB SPL] (floating)	upper limit [dB SPL] (floating)	f [Hz]	upper limit [%THD]
160	70	80	300	40
300	85	94	400	20
350	88	-	600	5
400	88	94	6300	5
1000	83	87		
2500	83	87		
4000	84	89		
7500	88	96		
8000	75	-		
10000	75	96		

2403 260 00106

3.2. Electro-Acoustic parameters

Loudspeaker mounted in adapter acc. to 3.10.

1. Rated impedance	Z:	32Ω
2. Voice coil resistance	R:	28.8Ω±10%
3. Resonance frequency (measured @10mW)	f ₀ :	350Hz±15%
4. Maximum usable excursion (peak-peak)	X _{max} :	0.6mm _{p-p}
5. Nominal characteristic sensitivity (calculated for 1W in 1m) average from 1kHz to 3kHz		65±2dB
5.1. Measured characteristic sensitivity (at 10mW in 1cm) average from 1kHz to 3kHz		85±2dB
6. THD	according chapter 3.1.	
7. Rub & buzz	< 60dB SPL (300Hz -1500Hz) in 1cm at 10mW (566mV _{eff})	

All acoustic measurements at 23±2°C

3.3. Power handling

Receiver mounted in lifetime test device (open rear/open front)

1. Max short term power	75mW (RMS)
Signal: pink noise HP 2 nd order 800Hz, LP 10 th order 6.3kHz, crest factor 2	
2. Max continuous power (500h)	10mW (RMS)
Signal: pink noise shaped according to diagram below: HP 10 th order 100Hz, HP 2 nd order 400Hz, LP 10 th order 6.3kHz, crest factor 2	

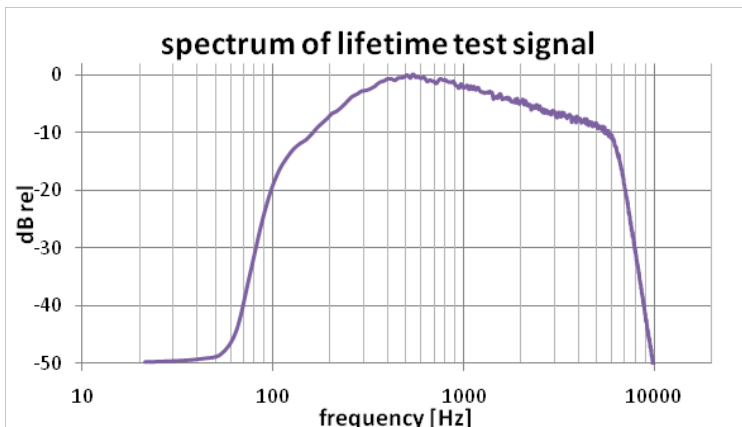

3.4. Measurement setup

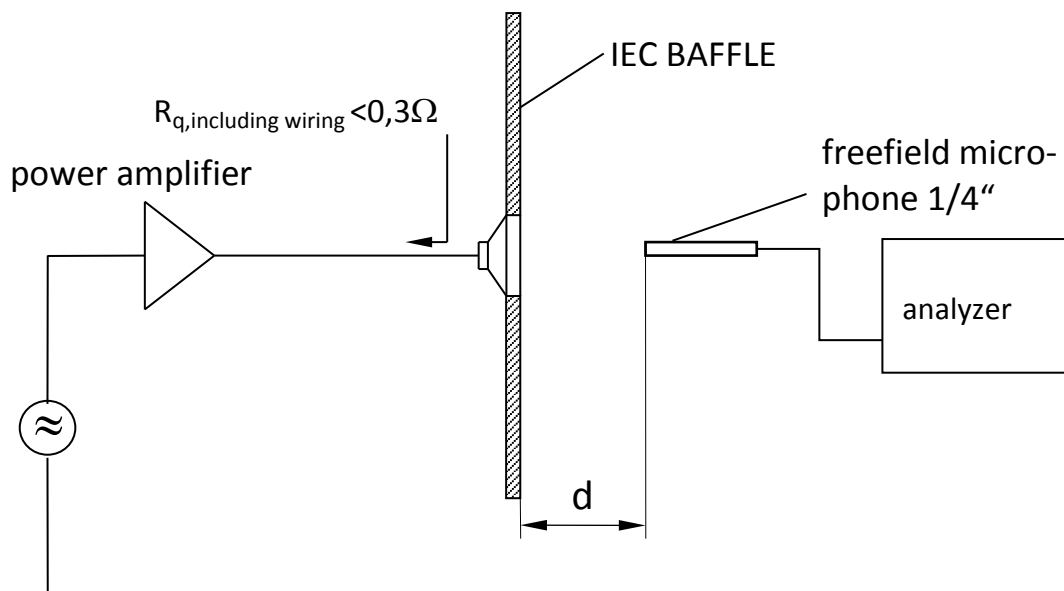

3.5. Measured parameters

3.5.1. Sensitivity

SPL is expressed in dB rel $20 \mu\text{Pa}$, computed according to IEC 268-5.

Measurement set up and parameters according chapter 3.4.

This test is performed for 100% of products in the production line.

3.5.2. Frequency response

Frequency response is measured according test set up in chapter 3.4 data sheet and checked against the tolerance window defined in chapter 3.1. This Test is performed for 100% of products in the production line.

3.5.3. Total harmonic distortion (THD)

Is measured according IEC 268-5 (2nd to 5th harmonics) and test set up in chapter 3.4. This test is performed for 100% of products in the production line.

3.5.4. Rub & buzz

Rub & Buzz will be measured in the Inline-measuring device with a sinusoidal sweep. Rub & Buzz is defined as the maximum level of no harmonic energy, expressed as signal to non-harmonic content ratio, in a certain frequency-range. Signal and evaluation criteria are according to chapter 3.2. This test is performed for 100% of products in the production line.

2403 260 00106

3.6. Measurement adapter

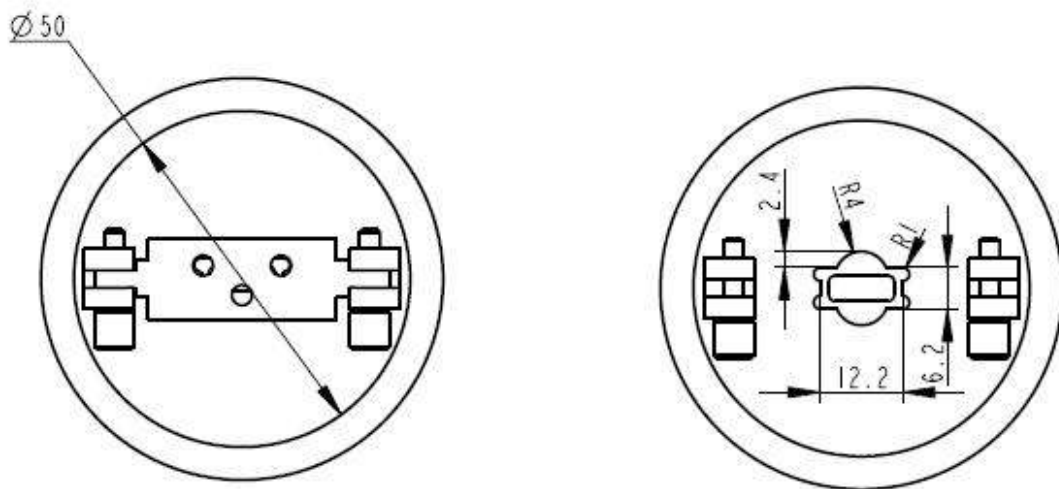
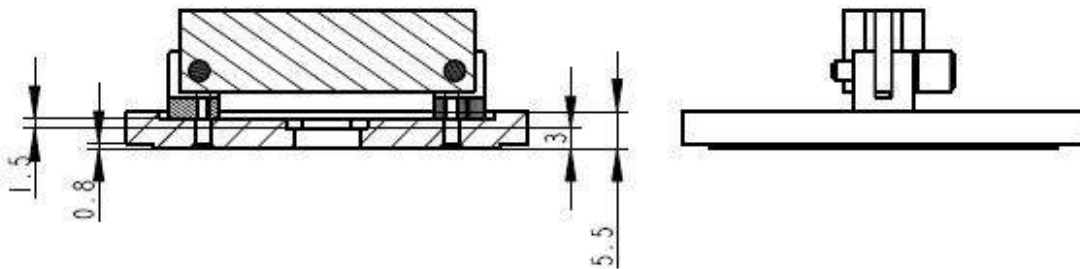
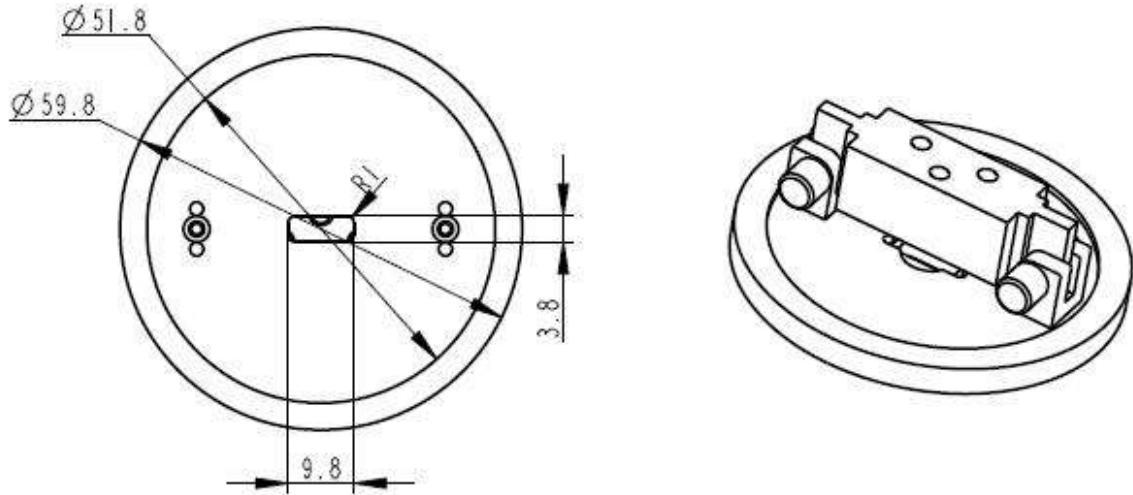

2403 260 00106

4. Environmental conditions

4.1. Storage

The transducer fulfills the specified data after treatment according to the conditions of

ETS 300 019-2-1 Specification of environmental test: Storage
Test spec. T 1.2: Weather protected, not temperature controlled storage locations.

4.2. Transportation

The transducer fulfills the specified data after treatment according to the conditions of

ETS 300 019-2-2 Specification of environmental test: Transportation
Test Spec. T 2.3: Public Transportation

4.3. Functionality

The transducer fulfills the specified data after treatment according to the conditions of

ETS 300 019-2-5 Specification of environmental test: Ground vehicle installations
Test spec. T 5.1: Protected installation

ETS 300 019-2-7 Specification of environmental test: Portable and non-stationary use
Test spec. T 7.3E: Partly weather protected and non-weather protected locations.

5. Environmental tests

5.1. Qualification tests

According to our milestone plan (Product Creation Process), a complete qualification test will be done at design validation of products manufactured under serial conditions.

1x per year and product family a requalification takes place. The qualification process covers all tests described under 5.5 and a complete inspection.

5.2. Reliability tests

1x per month and product family samples are taken and submitted to tests described under 5.5.2

5.3. Test sequence sample size

Unless otherwise stated 20 arbitrary new samples will be used to perform each test for both, qualification and requalification test as described under 5.1 and 5.2.

5.4. Period of shelf-life

The period of shelf-life is 2 years.

5.5. Testing procedures

5.5.1. Storage tests

5.5.1.1. Low temperature storage test

Parameter	Test Method and Conditions	Duration	Evaluation Standard
Low Temperature Storage (Ref. EN 60068-2-1)	-40°C rel. humidity not controlled	168h	Measurements after 2 hours recovery time. All samples fully operable. All acoustical parameters according specification with tolerances increased by 50 %.

5.5.1.2. High temperature storage test

Parameter	Test Method and Conditions	Duration	Evaluation Standard
Dry Heat Storage (Ref. EN 60068-2-2)	+85°C rel. humidity not controlled	168h	Measurements after 2 hours recovery time. All samples fully operable. All acoustical parameters according specification with tolerances increased by 50 %.

2403 260 00106

5.5.1.3. Temperature cycle test

Parameter	Test Method and Conditions	Duration	Evaluation Standard
Change of Temperature (Ref. EN 60068-2-14)	-40°C/+85°C Transition time <3 min. See Figure 5-1 below	5 cycles >2h for each temperature	Measurements after 2 hours recovery time. All samples fully operable. All acoustical parameters according specification with tolerances increased by 50 %.

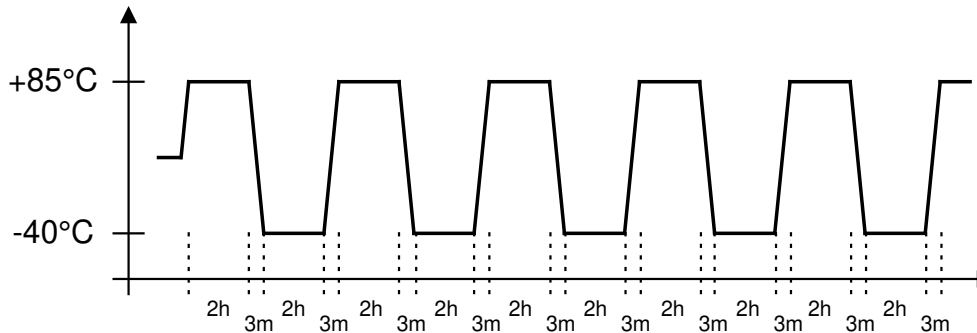

Figure 5-1: Temperature Cycle Test

5.5.1.4. Temperature / Humidity cycle test

Parameter	Test Method and Conditions	Duration	Evaluation Standard
Damp heat, cyclic (Ref. IEC 60068-2-30)	+25°C/+55°C 90% to 95% RH. Temp. change time <3h See Figure 5-2 below Caution: no condensed water on products!	6 cycles. 24h at each temperature	Measurements after 2 hours recovery time. All samples fully operable. All acoustical parameters according specification with tolerances increased by 50 %.

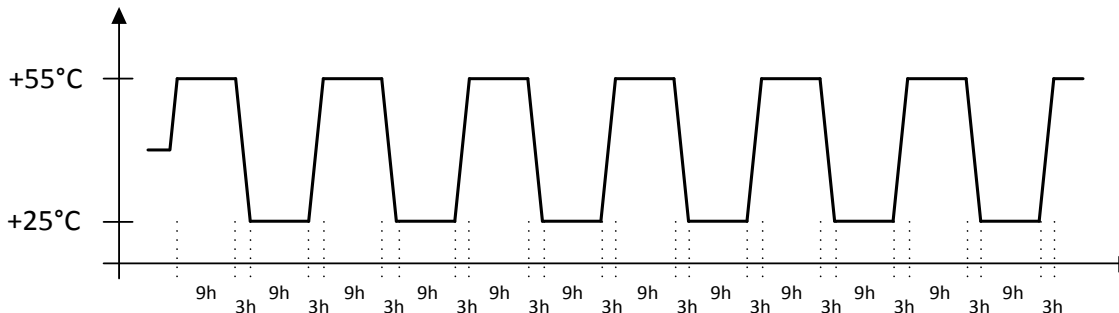

Figure 5-2: Temperature / Relative Humidity Cycle Test

2403 260 00106

5.5.2. Operating tests

5.5.2.1. Cold operation test

Parameter	Test Method and Conditions	Duration	Evaluation Standard
Cold Operation Test (Ref. EN 60068-2-1)	-20°C rel. humidity not controlled signal acc. Chapter 3.3	72h	Measurements after 2 hours recovery time. All samples fully operable. THD may be increased after test. All other acoustical parameters according specification with tolerances increased by 50 %.

5.5.2.2. Dry heat operation test

Parameter	Test Method and Conditions	Duration	Evaluation Standard
Dry Heat Operation (Ref. EN 60068-2-2)	+70°C rel. humidity not controlled signal acc. Chapter 3.3	500h	Measurements after 2 hours recovery time. All samples fully operable. The allowable change in sensitivity shall not be greater than 3 dB. All other acoustical parameters according specification with tolerances increased by 50 %.

5.5.3. Salt mist test

Parameter	Test Method and Conditions	Duration	Evaluation Standard
Salt Mist (Ref. IEC60068-2-52, Kb / Severity 2)	The part must be subjected to 2 hours spray of 5% NaCl salt mist, at 35°C then be left at 40°C and 95% RH for 22h.	3 cycles	The samples shall be washed after the test with distilled water and dried at T < 50°C. Component may have reduced performance, but must still function properly. The allowable sensitivity difference shall not be greater than ±3dB from initial sensitivity.



2403 260 00106

Shock resistance test (free fall test) - unprotected product

Parameter	Test Method and Conditions	Conditions / Sample size	Evaluation Standard
Mechanical shock (Ref. IEC60068-2-32 Ed), Procedure 1	Drop of sample without fixation of release plane from a height of 1.5m onto concrete floor.	Each 3 shocks in both directions of the 3 axes. (18 drops in total)	Component may have reduced performance, but must still function properly. The allowable sensitivity difference shall not be greater than $\pm 3\text{dB}$ from initial sensitivity.

5.5.4. Impact durability test (Tumble test) – protected product

Parameter	Test Method and Conditions	Conditions / Sample size	Evaluation Standard
Impact durability (in a Tumble Tester) (Ref. IEC60068-2-32 Ed) (SPR a7.1.1)	Speaker <i>in drop test box</i> or representative mechanics. Random drops on steel base.	30 units 180 drops, 1m DUT power off	Component may have reduced performance, but must still function properly. The allowable sensitivity difference shall not be greater than $\pm 3\text{ dB}$ from initial sensitivity.

5.5.5. Resistance to electrostatic discharge

Parameter	Test Method and Conditions	Conditions / Sample size	Evaluation Standard
Resistance to ESD IEC61000-4-2 Level 4 (SPR c 2.5.1)	One pole is grounded and the ESD pulse is applied to the other pole. The speaker must be stressed first with one polarisation and then with the other polarisation. DUT must be discharged between each ESD exposure. Level 4: contact +/- 8kV, air +/- 15kV	10 exposures on each polarity / 5 units DUT Power off	All samples fully operable. All acoustical parameters according specification with tolerances increased by 50%.

2403 260 00106

5.5.6. Water-resistance

Parameter	Test Method and Conditions	Conditions / Sample size	Evaluation Standard
Water resistant acc. IPx8 (Ref. IEC60529)	The part must be immersed in 1.5m of water for 30min in an appropriate test adapter.	10 units 1.5m, 30min	No ingress of water through the products allowed. Measurements after samples are dry. All samples fully operable. The allowable change in sensitivity shall not be greater than 3dB. All other acoustical parameters according specification with tolerances increased by 50%.

Related Documents

- IEC 268-5** Sound System equipment
Part 5: Loudspeaker
- IEC 68-2** Environmental testing
- EN 60068-2** Environmental testing
- IEC60529** Degrees of protection provided by enclosures (Ingress Protection Code)
- ISO 2859 - 1** Sampling procedures for inspection by attributes
Part 1: Sampling plans indexed by acceptable quality level (AQL) for lot-by-lot inspection
- ISO 3951** Sampling procedures and charts for inspection by variables for percent defectives.
- ETS 300 019-2-1** Specification of environmental test: Storage
Test spec. T 1.2: Weather protected, not temperature controlled storage locations
- ETS 300 019-2-2** Specification of environmental test: Transportation
Test spec. T 2.3: Public Transportation
- ETS 300 019-2-5** Specification of environmental test: Ground vehicle installations
Test spec. T 5.1: Protected installation
- ETS 300 019-2-7** Specification of environmental test: Portable and non-stationary use
Test spec. T 7.3E: Partly weather protected and non-weather protected locations



2403 260 00106

6. Change history

Status	Version	Date	ECR	Comment / Changes	Initials of owner
Release	A	12.07.13	4081	First release	MS/GZ/CP

7. Disclaimer

Stresses above the Absolute Maximum Ratings may cause permanent damage to the device. These are stress ratings only. The device may not function when operated at these or any other conditions beyond those indicated under “Electrical and Acoustical Specifications”. Exposure beyond those indicated under “Electrical and Acoustical Specifications” for extended periods may affect device reliability.

This product is not qualified for use in automotive applications

Frequency range in telecom application:
300 Hz – 3.4 kHz

The information contained in this literature is based on our experience to date and is believed to be reliable and it is subject to change without notice. It is intended as a guide for use by persons having technical skill at their own discretion and risk. We do not guarantee favorable results or assume any liability in connection with its use. Dimensions contained herein are for reference purposes only. For specific dimensional requirements consult factory. This publication is not to be taken as a license to operate under, or recommendation to infringe any exiting patents. This supersedes and voids all previous literature.