



HMS Industrial Networks AB
Web: www.anybus.com
Tel: +46 35 172900
E-mail: info@hms.se



SP1324, rev 2.01, Mar 2012. AB9001.

www.anybus.com

Module Front

USB port:
Connect a PC to the USB port for firmware upgrades.

PROFIBUS Connector (DB9F):

Pin no	Description
1	Shield
3	B-Line
4	RTS
5	GND bus
6	+5 V bus out
8	A-Line
2, 7, 9	Not connected
Housing	PE

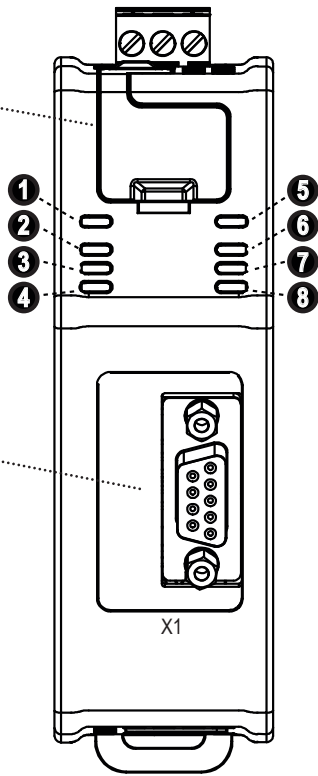
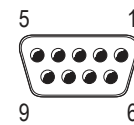

LEDs: X-gateway and Modbus-TCP Network

No	Name	Indication	Meaning
1	(GW) Gateway Status	Off Alternating red/green Flashing green Green Running Flashing red Red	Power off Missing configuration Idle Running Invalid configuration Fatal error
5	(SD) SD Card Status	Green Flashing red	Accessing SD card Failure
6	(MTCP) Modbus-TCP Status	Off Green Flashing red Red	No Modbus-TCP network communication Communicating with Modbus-TCP network Transaction error or timeout Fatal error
7	(LA1, LA2) Ethernet Link 1 & 2	Off Flashing green	No link Receiving/transmitting Ethernet packets at 100 Mbit
8		Flashing yellow	Receiving/transmitting Ethernet packets at 10 Mbit

LEDs: PROFIBUS Network

No	Name	Indication	Meaning
2	Not used	-	-
3	(OP) Network Status	Off Flashing green Green Flashing red (1 flash) Flashing red (2 flashes)	Not online Online, clear Online, data exchange Parameterization error Configuration error
4	(ST) Module Status	Off Green Red	Not initialized Initialized Fatal error

Installation and Startup Summary

- Attach the X-gateway to the DIN-rail.
- Connect the module to the PROFIBUS network.
- Connect the module to the Modbus-TCP network.
- Turn on the module (+24 V DC).
- Download IPconfig from www.anybus.com to a PC.
- Connect the PC to the module via one of the Modbus-TCP connectors (Ethernet crossover cable not necessary). Use IPconfig to identify the IP address of the module on the network using its Modbus-TCP MAC address (found at the bottom of the module).
- Start a web browser (IE 7.0 or 8.0), enter the IP address and connect to the X-gateway's web interface.
- Configure the module using the web configuration pages.
- Include the Anybus X-gateway GSD file in the PROFIBUS configuration tool (download the GSD file from www.anybus.com).
- Configure and start the PROFIBUS network.

Top View

Power:
(+) +24 V DC
(-) GND
(⊕) PE

SD card slot:

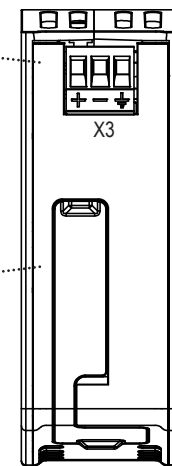

Bottom View

Modbus-TCP Connector:

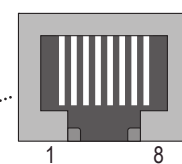
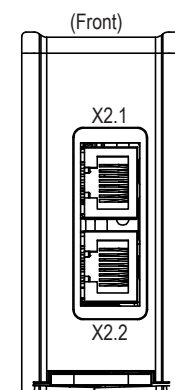

Pin no	Description
1	TX+
2	TX-
3	RX+
6	RX-
4, 5, 7, 8	Termination

Technical Details

- Power supply:
24 V DC (-15% to +20%).
- Power consumption:
Maximum power consumption is 300 mA @ 24 V DC.
Typical power consumption: 150 mA @ 24 V DC.
- Surrounding temperature
70 degrees C @ 225 mA @ 24 V DC.
- Protective Earth (PE):
Internal connection to PE via DIN-rail or, if the DIN-rail can not be used, via the power connector.
Note: Make sure the DIN-rail is properly connected to PE.

For maintenance and support, contact the HMS support department. Contact information is available at the support pages on www.anybus.com.

Further information and documents about this product can be found at the product pages on www.anybus.com.

Anybus X-gateway Modbus-TCP INSTALLATION SHEET

DIN-rail Mounting

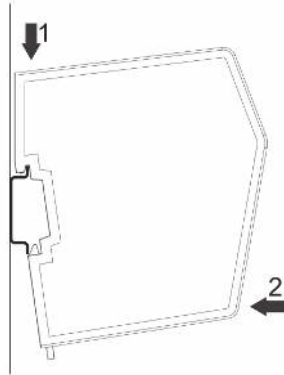

Make sure the DIN-rail fastening mechanism on the back of the module is in a fixed and closed position, i. e. pushed all the way up.

To mount the module, first hook it on to the DIN-rail (1), then push it against the DIN-rail to make it snap on (2).

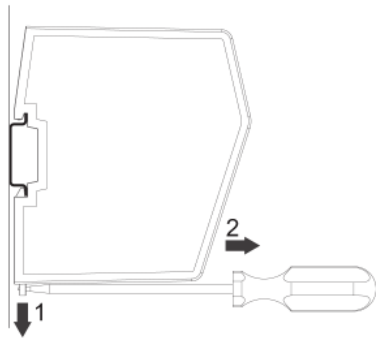

To unmount the module, a screwdriver is needed. Use the screwdriver to push the DIN-rail fastening mechanism on the back of the module down until it locks in a fixed and open position (1). Then unhook the module from the DIN-rail (2).

Note: Do not leave the module with the DIN-rail fastening mechanism in a fixed and open position. This may eventually wear the fastening mechanism out so it cannot be used efficiently. Be sure to push the DIN-rail fastening mechanism back into the fixed and closed position after unmounting the module, according to the picture below.

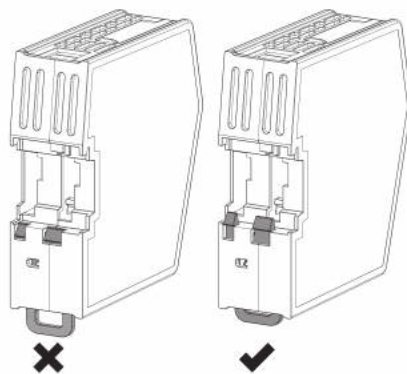

Additional Installation and Operating Instructions

Supply voltage: The X-gateway requires a regulated 24 V (20.4 V to 28.8 V) DC power source.

Field wiring terminal markings (wire type (Cu only, 14-30AWG)
"Use 105°C copper (CU) wire only"
Terminal tightening torque (5-7 lb-in)).

Use in Overvoltage Category I Pollution Degree 2 Environment.

Install in an enclosure considered representative of the intended use. To comply with ATEX directives, the equipment must be installed within an IP54 enclosure and must be installed with a transient suppressor on the supply that does not exceed 140% (33.6 V DC) of the nominal rated supply voltage.

Operating temperature/Surrounding temperature:
-25 to +60 degrees C @ 300 mA @ 24 V DC.

In order to sustain high operating temperatures of up to 70 degrees C @ 225 mA, the module must be mounted vertically (power connector facing upwards) to ensure optimal vertical airflow. Additionally, if the module is mounted side-by-side with other modules, this will affect the module's ability to sustain high operating temperatures.

Maximum surface temperature: 135 degrees C.

Pressure: 850 - 1050 millibar.

This product is designed to safely operate in class I, division 2 Hazardous location according to ANSI/ISA 12.12.01-2011 and category 3, zone 2 according to EN 60079-0 and EN 60079-15.

SUITABLE FOR USE IN CLASS I, DIVISION 2, GROUPS A, B, C AND D HAZARDOUS LOCATIONS, OR NONHAZARDOUS LOCATIONS ONLY.

Label Markings

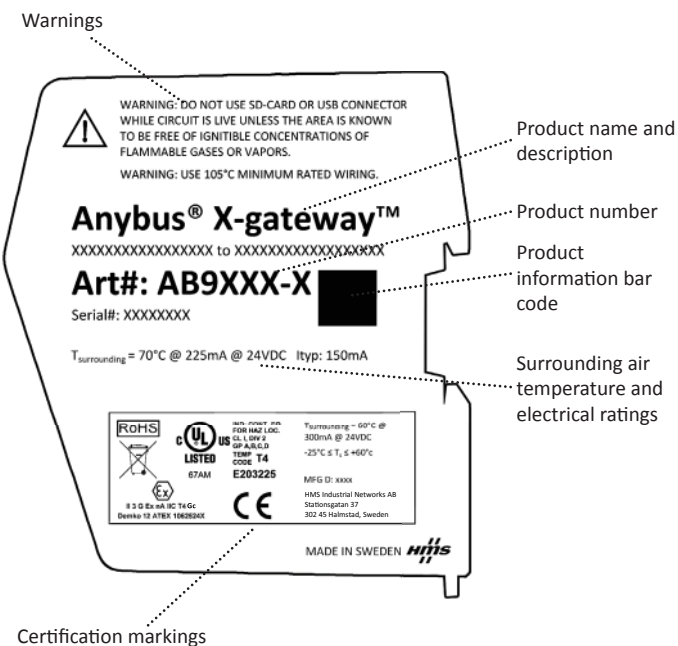

Warnings

- **WARNING - EXPLOSION HAZARD - SUBSTITUTION OF ANY COMPONENTS MAY IMPAIR SUITABILITY FOR CLASS I, DIVISION 2.**
- **WARNING - EXPLOSION HAZARD - WHEN IN HAZARDOUS LOCATIONS, TURN OFF POWER BEFORE REPLACING OR WIRING MODULES.**
- **WARNING - EXPLOSION HAZARD - DO NOT DISCONNECT EQUIPMENT WHILE THE CIRCUIT IS LIVE OR UNLESS THE AREA IS KNOWN TO BE FREE OF IGNITIBLE CONCENTRATIONS.**
- **WARNING - EXPLOSION HAZARD- THE USB CONNECTOR IS NOT FOR USE IN HAZARDOUS LOCATIONS AND FOR TEMPORARY CONNECTION ONLY. DO NOT USE, CONNECT OR DISCONNECT UNLESS THE AREA IS KNOWN TO BE NONHAZARDOUS. CONNECTION OR DISCONNECTION IN AN EXPLOSIVE ATMOSPHERE COULD RESULT IN AN EXPLOSION.**
- **WARNING - EXPLOSION HAZARD - DO NOT CONNECT OR DISCONNECT THE SD CARD UNLESS THE AREA IS KNOWN TO BE NONHAZARDOUS. CONNECTION OR DISCONNECTION IN AN EXPLOSIVE ATMOSPHERE COULD RESULT IN AN EXPLOSION.**
- **WARNING - INSTALL IN AN ENCLOSURE CONSIDERED REPRESENTATIVE OF THE INTENDED USE. TO COMPLY WITH ATEX DIRECTIVES, THE EQUIPMENT MUST BE INSTALLED WITHIN AN IP54 ENCLOSURE AND MUST BE INSTALLED WITH A TRANSIENT SUPPRESSOR ON THE SUPPLY THAT DOES NOT EXCEED 140% (33.6 V DC) OF THE NOMINAL RATED SUPPLY VOLTAGE.**

UL Certification



LISTED 67AM

Atex Certification

EX nA IIC T4 Gc



Demko 12 ATEX 1062524X

EMC Compliance (CE)



This product is in accordance with the EMC directive 2004/108/EC through conformance with the following standards:

- **EN 61000-6-4 (2007)**
Emission standard for industrial environment
EN 55016-2-3, Class A (2006)
- **EN 61000-6-2 (2005)**
Immunity for industrial environment
EN 61000-4-2 (2009)
EN 61000-4-3 (2006)
EN 61000-4-4 (2004)
EN 61000-4-5 (2005)
EN 61000-4-6 (2007)

HMS Industrial Networks AB
Stationsgatan 37
302 45 Halmstad
Sweden



Further information and documents about this product can be found at the product pages on www.anybus.com.